

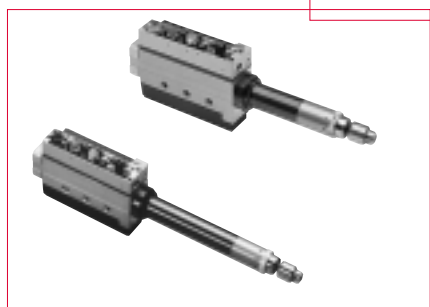

AFD205/AFD215 pneumatic drive



- Options of compact AFD205 or long stroke AFD215
- High thrust/size ratio
- Capacity up to 5mm (3/16") in aluminium
- Modular output spindles

Lou Zampini & Associates

2 Douglas Pike, Rt. 7

Smithfield, RI 02917

1 800 353 4676

FAX 1 401 679 0165

AFD205

drilling performance specification

TOOL TYPE	SPEED		POWER		THRUST		STROKE		WEIGHT		AIR CONSUMPTION		SOUND LEVEL
	rpm		kW	HP	N	lbf	mm	ins	kg	lb	l/s ²	cfm	dB(A)
model code	no load speed		motor power		dynamic thrust		working stroke		weight		continuous running		
AFD205-650	650		0.22	0.30	400	90	50	1.97	3.9	8.6	9.5	20	75
AFD205-1000	1000		0.22	0.30	400	90	50	1.97	3.9	8.6	9.5	20	75
AFD205-2700	2700		0.22	0.30	400	90	50	1.97	3.9	8.6	9.5	20	75
AFD205-4350	4350		0.22	0.30	400	90	50	1.97	3.9	8.6	9.5	20	75
AFD205-10000	10000		0.22	0.30	400	90	50	1.97	3.9	8.6	9.5	20	75
AFD205-18700	18700		0.22	0.30	400	90	50	1.97	3.9	8.6	9.5	20	75

AFD215

drilling performance specification

TOOL TYPE	SPEED		POWER		THRUST		STROKE		WEIGHT		AIR CONSUMPTION		SOUND LEVEL
	rpm		kW	HP	N	lbf	mm	ins	kg	lb	l/s ²	cfm	dB(A)
model code	no load speed		motor power		dynamic thrust		working stroke		weight		continuous running		
AFD215-650	650		0.22	0.30	400	90	90	3.54	4.2	9.2	9.5	20	75
AFD215-1000	1000		0.22	0.30	400	90	90	3.54	4.2	9.2	9.5	20	75
AFD215-2700	2700		0.22	0.30	400	90	90	3.54	4.2	9.2	9.5	20	75
AFD215-4350	4350		0.22	0.30	400	90	90	3.54	4.2	9.2	9.5	20	75
AFD215-10000	10000		0.22	0.30	400	90	90	3.54	4.2	9.2	9.5	20	75
AFD215-18700	18700		0.22	0.30	400	90	90	3.54	4.2	9.2	9.5	20	75

AFD205/AFD215 accessories

ACCESSORIES RANGE	PAGE
Control Blocks	28
Output Spindles	30
Multiple Spindle Heads	34
Clamps	38

AFD205/AFD215 pneumatic drive

AFD205 pneumatic drive

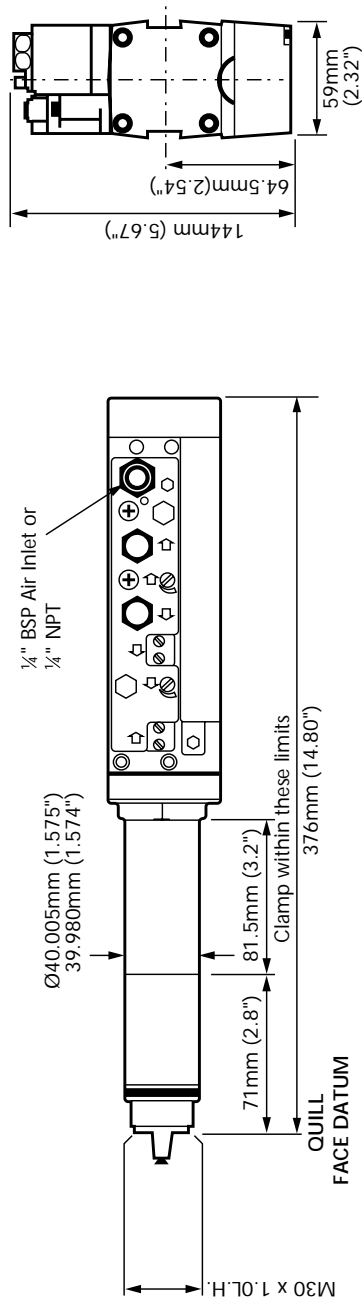

AFD215 pneumatic drive

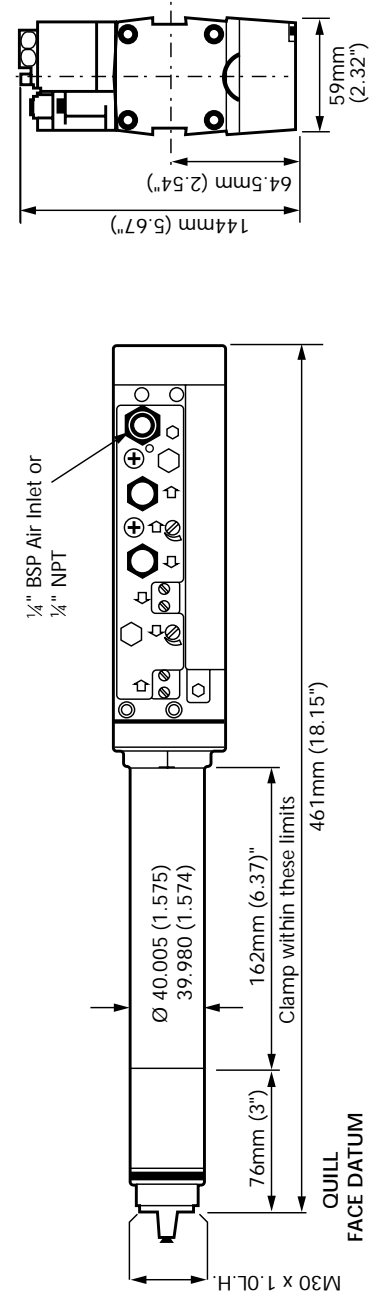

AFD415 pneumatic drive



- Compact unit design
- Long working stroke of 100mm (3.94")
- Spindle sealed to IP64 standard
- Capacity up to 8mm (5/16") in mild steel, 10mm (3/8") in aluminium
- Modular output spindles

AFD415

drilling performance specification

TOOL TYPE	SPEED		POWER		THRUST		STROKE		WEIGHT		AIR CONSUMPTION		SOUND LEVEL
	rpm		kW	HP	N	lbf	mm	ins	kg	lb	l/s ²	cfm	
model code	no load speed		motor power		dynamic thrust		working stroke		weight		continuous running		
AFD415-490	490		0.38	0.51	706	159	100	3.94	6.2	13.7	9.9	21	75
AFD415-790	790		0.38	0.51	706	159	100	3.94	6.2	13.7	9.9	21	75
AFD415-1250	1250		0.38	0.51	706	159	100	3.94	6.2	13.7	9.9	21	75
AFD415-2100	2100		0.38	0.51	706	159	100	3.94	6.2	13.7	9.9	21	75
AFD415-3400	3400		0.38	0.51	706	159	100	3.94	6.2	13.7	9.9	21	75
AFD415-5400	5400		0.38	0.51	706	159	100	3.94	6.2	13.7	9.9	21	75
AFD415-7000	7000		0.38	0.51	706	159	100	3.94	6.2	13.7	9.9	21	75
AFD415-18000	18000		0.38	0.51	706	159	100	3.94	6.2	13.7	9.9	21	75

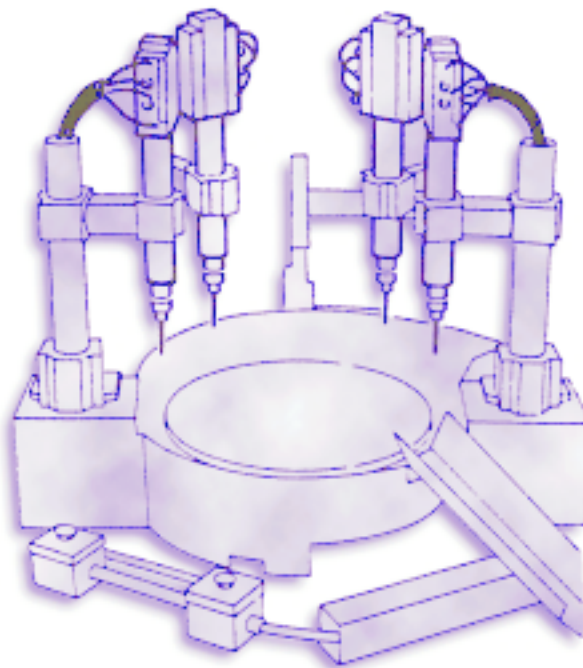



AFD60 pneumatic drive



- Heavy duty pneumatic unit
- Chuck supplied fitted to tool, 10mm (3/8") for 1600-4300rpm and 13mm (1/2") for 550-1000rpm
- Full feature control block fitted as standard
- Capacity up to 16mm (5/8") in aluminium, 12mm (1/2") in mild steel

AFD60

drilling performance specification

TOOL TYPE	SPEED		POWER		THRUST		STROKE		WEIGHT		AIR CONSUMPTION		SOUND LEVEL
	rpm		kW	HP	N	lbf	mm	ins	kg	lb	l/s ²	cfm	dB(A)
model code	no load speed		motor power		dynamic thrust		working stroke		weight		continuous running		
AFD60-550	550		0.52	0.70	1200	269	95	3.74	8.1	17.8	15.6	33	77
AFD60-700	700		0.52	0.70	1200	269	95	3.74	8.1	17.8	15.6	33	77
AFD60-1000	1000		0.52	0.70	1200	269	95	3.74	8.1	17.8	15.6	33	77
AFD60-1600	1600		0.52	0.70	1200	269	95	3.74	8.1	17.8	15.6	33	77
AFD60-2100	2100		0.52	0.70	1200	269	95	3.74	8.1	17.8	15.6	33	77
AFD60-3000	3000		0.52	0.70	1200	269	95	3.74	8.1	17.8	15.6	33	77
AFD60-4300	4300		0.52	0.70	1200	269	95	3.74	8.1	17.8	15.6	33	77

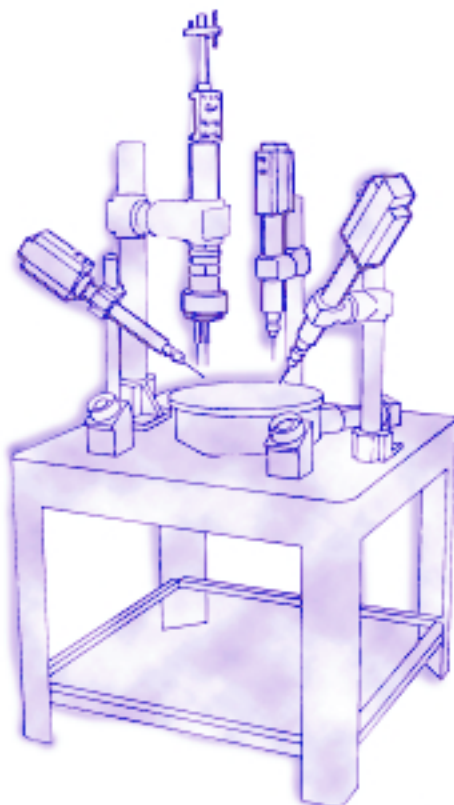

AFD60 accessories

ACCESSORIES RANGE	PAGE
Control Options	29
Multiple Spindle Heads	34
Clamps	40

AFD60 pneumatic drive

