

**Lou Zampini & Associates**  
 2 Douglas Pike, Rt. 7  
 Smithfield, RI 02917  
 1 800 353 4676  
 FAX 1 401 679 0165

AFDE200 accessories

ACCESSORIES RANGE	PAGE
Control Blocks	28
Output Spindles	30
Multiple Spindle Heads	34
Clamps	38

AFDE200 electric drive

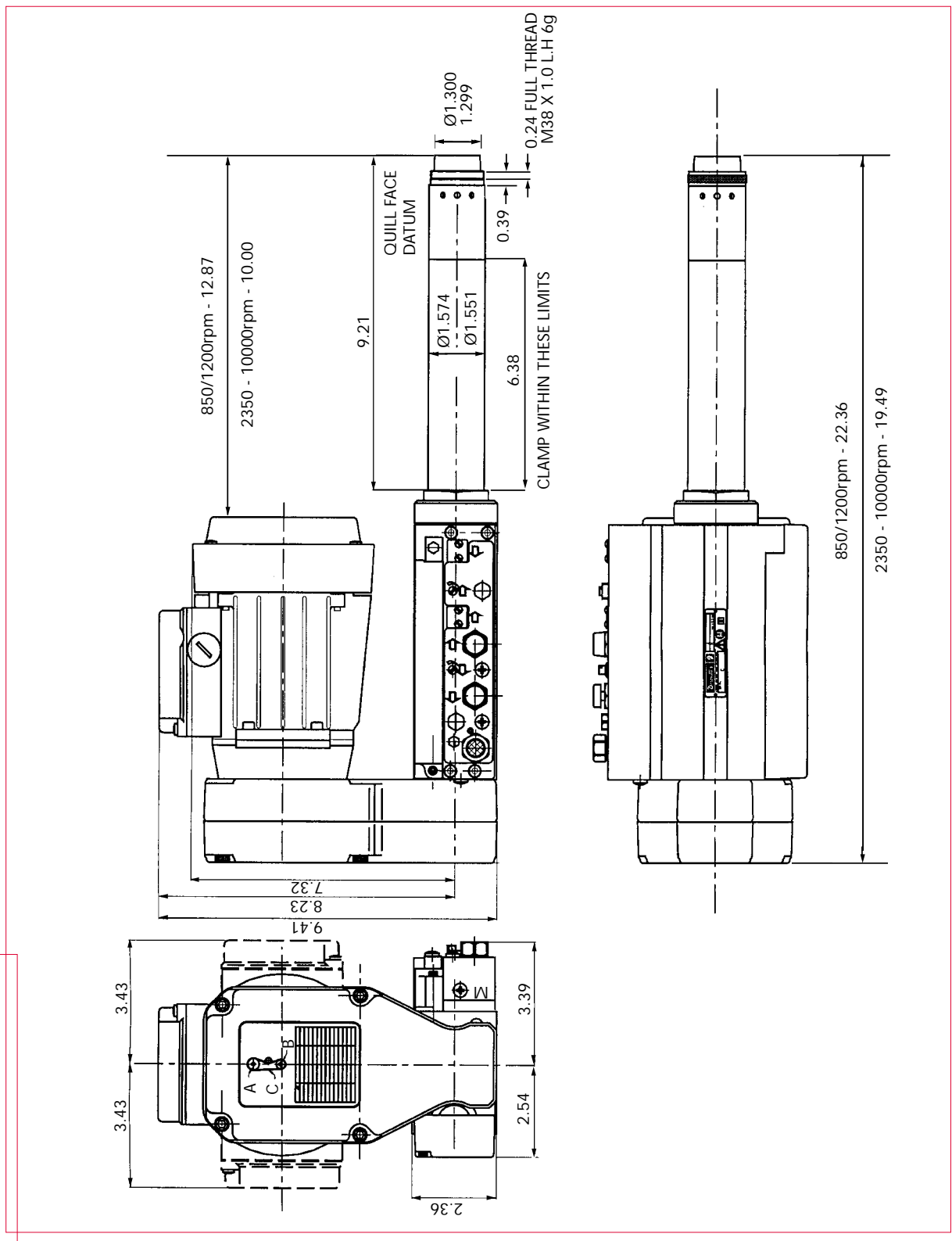



## AFDE400/AFDE410 electric drive

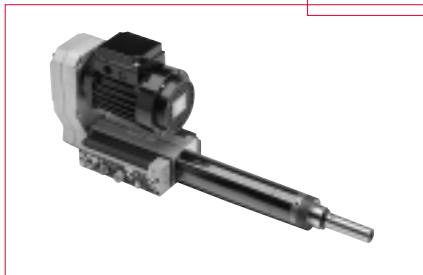

- Comprehensive speed range 330-10000 rpm @ 50Hz, 400-11900 rpm @ 60Hz
- 0.44HP (0.33kW) and 1.00HP (0.75kW) options
- Capacity up to 3/8" (10mm) in aluminium or 5/16" (8mm) in mild steel
- Spindle sealed to IP64 standard
- Modular output spindles

## AFDE400

drilling performance specification

TOOL TYPE	SPEED		POWER		CURRENT		THRUST		STROKE		WEIGHT		AIR CONSUMPTION		SOUND LEVEL
	rpm		kW	HP	Amps		N	lbf	mm	ins	kg	lb	l/s <sup>2</sup>	cfm	dB(A)
model code	50Hz	60Hz	motor power		50Hz	60Hz	dynamic thrust		working stroke		weight		per cycle		
AFDE400-330	330	400	0.33	0.44	0.95	0.95	724	163	100	3.94	11.4	25.1	<1	<0.04	<70
AFDE400-550	550	660	0.33	0.44	0.95	0.95	724	163	100	3.94	11.4	25.1	<1	<0.04	<70
AFDE400-900	900	1100	0.33	0.44	0.95	0.95	724	163	100	3.94	11.4	25.1	<1	<0.04	<70
AFDE400-1200	1200	1450	0.33	0.44	0.95	0.95	724	163	100	3.94	11.4	25.1	<1	<0.04	<70
AFDE400-1450	1450	1740	0.33	0.44	0.95	0.95	724	163	100	3.94	11.4	25.1	<1	<0.04	<70
AFDE400-1750	1750	2100	0.33	0.44	0.95	0.95	724	163	100	3.94	11.4	25.1	<1	<0.04	<70
AFDE400-2350	2350	2820	0.33	0.44	0.95	0.95	724	163	100	3.94	11.4	25.1	<1	<0.04	<70
AFDE400-2850	2850	3400	0.33	0.44	0.95	0.95	724	163	100	3.94	11.4	25.1	<1	<0.04	<70
AFDE400-3750	3750	4500	0.33	0.44	0.95	0.95	724	163	100	3.94	11.4	25.1	<1	<0.04	<70
AFDE400-4600	4600	5450	0.33	0.44	0.95	0.95	724	163	100	3.94	11.4	25.1	<1	<0.04	<70
AFDE400-5250	5250	6300	0.33	0.44	0.95	0.95	724	163	100	3.94	11.4	25.1	<1	<0.04	<70
AFDE400-8000	8000	9600	0.33	0.44	0.95	0.95	724	163	100	3.94	11.4	25.1	<1	<0.04	<70
AFDE400-10000	10000	11950	0.33	0.44	0.95	0.95	724	163	100	3.94	11.4	25.1	<1	<0.04	<70

## AFDE410

drilling performance specification

TOOL TYPE	SPEED		POWER		CURRENT		THRUST		STROKE		WEIGHT		AIR CONSUMPTION		SOUND LEVEL
	rpm		kW	HP	Amps		N	lbf	mm	ins	kg	lb	l/s <sup>2</sup>	cfm	dB(A)
model code	50Hz	60Hz	motor power		50Hz	60Hz	dynamic thrust		working stroke		weight		per cycle		
AFDE410-330	330	400	0.75	1.00	1.9	1.9	724	163	100	3.94	12.4	27.3	<1	<0.04	<70
AFDE410-550	550	660	0.75	1.00	1.9	1.9	724	163	100	3.94	12.4	27.3	<1	<0.04	<70
AFDE410-900	900	1100	0.75	1.00	1.9	1.9	724	163	100	3.94	12.4	27.3	<1	<0.04	<70
AFDE410-1200	1200	1450	0.75	1.00	1.9	1.9	724	163	100	3.94	12.4	27.3	<1	<0.04	<70
AFDE410-1450	1450	1740	0.75	1.00	1.9	1.9	724	163	100	3.94	12.4	27.3	<1	<0.04	<70
AFDE410-1750	1750	2100	0.75	1.00	2.0	2.0	724	163	100	3.94	12.4	27.3	<1	<0.04	<70
AFDE410-2350	2350	2820	0.75	1.00	2.0	2.0	724	163	100	3.94	12.4	27.3	<1	<0.04	<70
AFDE410-2850	2850	3400	0.75	1.00	2.0	2.0	724	163	100	3.94	12.4	27.3	<1	<0.04	<70
AFDE410-3750	3750	4500	0.75	1.00	2.0	2.0	724	163	100	3.94	12.4	27.3	<1	<0.04	<70
AFDE410-4600	4600	5450	0.75	1.00	2.0	2.0	724	163	100	3.94	12.4	27.3	<1	<0.04	<70
AFDE410-5250	5250	6300	0.75	1.00	2.0	2.0	724	163	100	3.94	12.4	27.3	<1	<0.04	<70
AFDE410-8000	8000	9600	0.75	1.00	2.0	2.0	724	163	100	3.94	12.4	27.3	<1	<0.04	<70

AFDE400/AFDE410 accessories

ACCESSORIES RANGE	PAGE
Control Blocks	28
Output Spindles	30
Multiple Spindle Heads	34
Clamps	39

AFDE400/AFDE410 electric drive

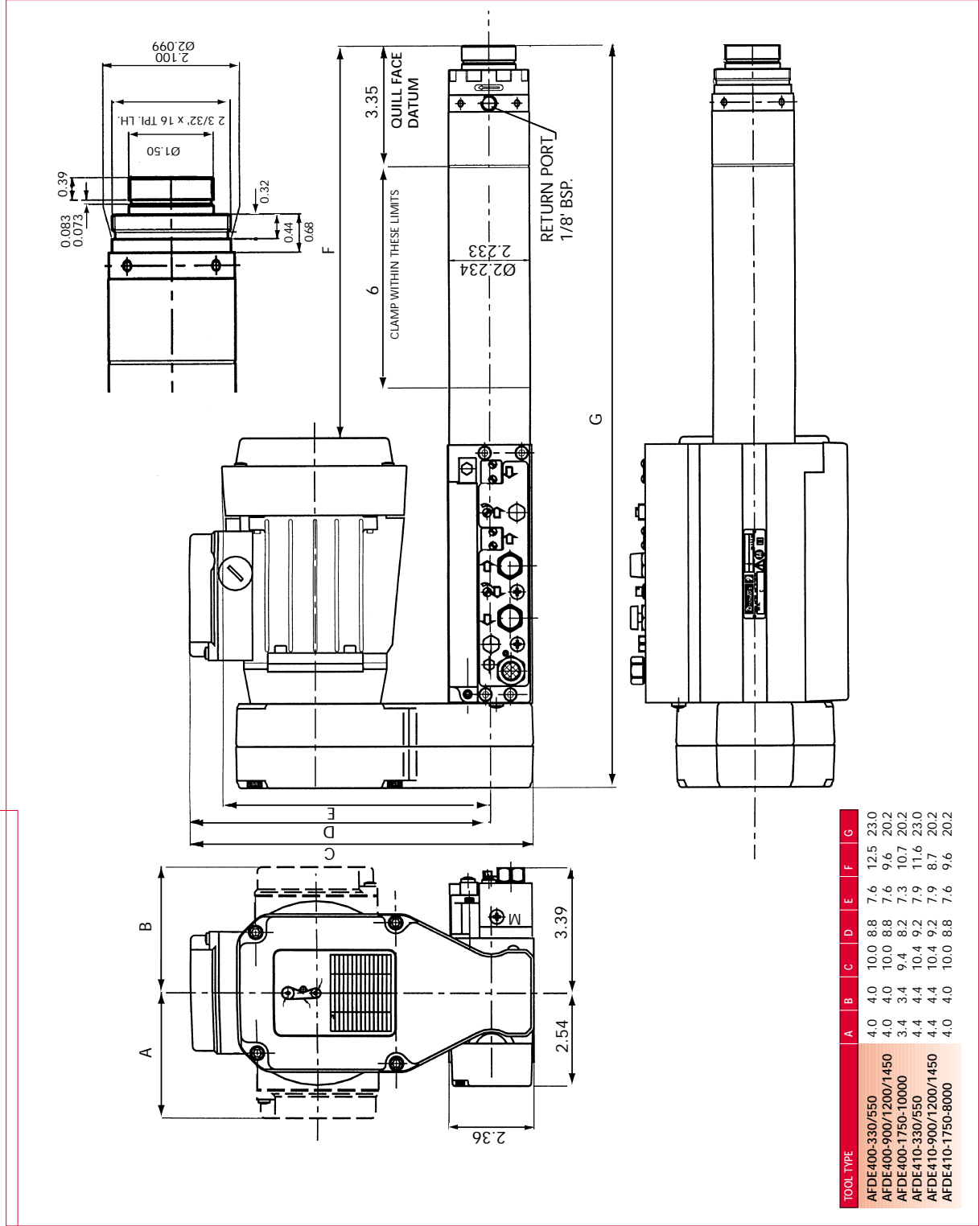

TOOL TYPE	A	B	C	D	E	F	G
AFDE400-330/550	4.0	4.0	10.0	8.8	7.6	12.5	23.0
AFDE400-900/1200/1450	4.0	4.0	10.0	8.8	7.6	9.6	20.2
AFDE400-1750-10000	3.4	3.4	9.4	8.2	7.3	10.7	20.2
AFDE410-330/550	4.4	4.4	10.4	9.2	7.9	11.6	23.0
AFDE410-900/1200/1450	4.4	4.4	10.4	9.2	7.9	8.7	20.2
AFDE410-1750-8000	4.0	4.0	10.0	8.8	7.6	9.6	20.2



## AFDE600/AFDE610/AFDE620 electric drive

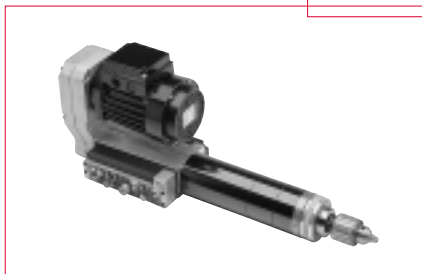

- 3 power ratings to give optimum power/thrust combination
- Heavy duty belts and pulley drive with integral belt tensioner
- Capacity up to 1/2" (12mm) in mild steel
- Spindle sealed to IP64 standard
- Modular output spindles

### AFDE600

drilling performance specification

TOOL TYPE	SPEED		POWER		CURRENT		THRUST		STROKE		WEIGHT		AIR CONSUMPTION		SOUND LEVEL
	rpm		kW	HP	Amps		N	lbf	mm	ins	kg	lb	l/s <sup>2</sup>	cfm	dB(A)
model code	50Hz	60Hz	motor power		50Hz	60Hz	dynamic thrust		working stroke		weight		per cycle		
AFDE600-330	330	400	0.33	0.44	0.95	0.95	1557	350	100	3.94	17.4	38.3	<2.5	<0.09	<70
AFDE600-550	550	660	0.33	0.44	0.95	0.95	1557	350	100	3.94	17.4	38.3	<2.5	<0.09	<70
AFDE600-900	900	1100	0.33	0.44	0.95	0.95	1557	350	100	3.94	17.4	38.3	<2.5	<0.09	<70
AFDE600-1200	1200	1450	0.33	0.44	0.95	0.95	1557	350	100	3.94	17.4	38.3	<2.5	<0.09	<70
AFDE600-1450	1450	1740	0.33	0.44	0.95	0.95	1557	350	100	3.94	17.4	38.3	<2.5	<0.09	<70
AFDE600-1750	1750	2100	0.33	0.44	0.95	0.95	1557	350	100	3.94	17.4	38.3	<2.5	<0.09	<70
AFDE600-2350	2350	2820	0.33	0.44	0.95	0.95	1557	350	100	3.94	17.4	38.3	<2.5	<0.09	<70
AFDE600-2850	2850	3400	0.33	0.44	0.95	0.95	1557	350	100	3.94	17.4	38.3	<2.5	<0.09	<70
AFDE600-3750	3750	4500	0.33	0.44	0.95	0.95	1557	350	100	3.94	17.4	38.3	<2.5	<0.09	<70
AFDE600-4600	4600	5450	0.33	0.44	0.95	0.95	1557	350	100	3.94	17.4	38.3	<2.5	<0.09	<70
AFDE600-5250	5250	6300	0.33	0.44	0.95	0.95	1557	350	100	3.94	17.4	38.3	<2.5	<0.09	<70

### AFDE610

drilling performance specification

TOOL TYPE	SPEED		POWER		CURRENT		THRUST		STROKE		WEIGHT		AIR CONSUMPTION		SOUND LEVEL
	rpm		kW	HP	Amps		N	lbf	mm	ins	kg	lb	l/s <sup>2</sup>	cfm	dB(A)
model code	50Hz	60Hz	motor power		50Hz	60Hz	dynamic thrust		working stroke		weight		per cycle		
AFDE610-330	330	400	0.75	1.00	1.9	1.9	1557	350	100	3.94	18.4	40.5	<2.5	<0.09	<70
AFDE610-550	550	660	0.75	1.00	1.9	1.9	1557	350	100	3.94	18.4	40.5	<2.5	<0.09	<70
AFDE610-900	900	1100	0.75	1.00	1.9	1.9	1557	350	100	3.94	18.4	40.5	<2.5	<0.09	<70
AFDE610-1200	1200	1450	0.75	1.00	1.9	1.9	1557	350	100	3.94	18.4	40.5	<2.5	<0.09	<70
AFDE610-1450	1450	1740	0.75	1.00	2.0	2.0	1557	350	100	3.94	18.4	40.5	<2.5	<0.09	<70
AFDE610-1750	1750	2100	0.75	1.00	2.0	2.0	1557	350	100	3.94	18.4	40.5	<2.5	<0.09	<70
AFDE610-2350	2350	2820	0.75	1.00	2.0	2.0	1557	350	100	3.94	18.4	40.5	<2.5	<0.09	<70
AFDE610-2850	2850	3400	0.75	1.00	2.0	2.0	1557	350	100	3.94	18.4	40.5	<2.5	<0.09	<70
AFDE610-3750	3750	4500	0.75	1.00	2.0	2.0	1557	350	100	3.94	18.4	40.5	<2.5	<0.09	<70
AFDE610-4600	4600	5450	0.75	1.00	2.0	2.0	1557	350	100	3.94	18.4	40.5	<2.5	<0.09	<70
AFDE610-5250	5250	6300	0.75	1.00	2.0	2.0	1557	350	100	3.94	18.4	40.5	<2.5	<0.09	<70

### AFDE620

drilling performance specification

TOOL TYPE	SPEED		POWER		CURRENT		THRUST		STROKE		WEIGHT		AIR CONSUMPTION		SOUND LEVEL
	rpm		kW	HP	Amps		N	lbf	mm	ins	kg	lb	l/s <sup>2</sup>	cfm	dB(A)
model code	50Hz	60Hz	motor power		50Hz	60Hz	dynamic thrust		working stroke		weight		per cycle		
AFDE620-330	330	400	1.10	1.47	2.8	2.8	1557	350	100	3.94	22	48.4	<2.5	<0.09	<70
AFDE620-550	550	660	1.10	1.47	2.8	2.8	1557	350	100	3.94	22	48.4	<2.5	<0.09	<70
AFDE620-900	900	1100	1.10	1.47	2.8	2.8	1557	350	100	3.94	22	48.4	<2.5	<0.09	<70
AFDE620-1200	1200	1450	1.10	1.47	2.8	2.8	1557	350	100	3.94	22	48.4	<2.5	<0.09	<70
AFDE620-1450	1450	1740	1.10	1.47	2.8	2.8	1557	350	100	3.94	22	48.4	<2.5	<0.09	<70
AFDE620-1750	1750	2100	1.10	1.47	2.5	2.5	1557	350	100	3.94	22	48.4	<2.5	<0.09	<70
AFDE620-2350	2350	2820	1.10	1.47	2.5	2.5	1557	350	100	3.94	22	48.4	<2.5	<0.09	<70
AFDE620-2850	2850	3400	1.10	1.47	2.5	2.5	1557	350	100	3.94	22	48.4	<2.5	<0.09	<70
AFDE620-3750	3750	4500	1.10	1.47	2.5	2.5	1557	350	100	3.94	22	48.4	<2.5	<0.09	<70
AFDE620-4600	4600	5450	1.10	1.47	2.5	2.5	1557	350	100	3.94	22	48.4	<2.5	<0.09	<70
AFDE620-5250	5250	6300	1.10	1.47	2.5	2.5	1557	350	100	3.94	22	48.4	<2.5	<0.09	<70

AFDE600/AFDE610/AFDE620 accessories

ACCESSORIES RANGE	PAGE
Control Blocks	28
Output Spindles	30
Multiple Spindle Heads	34
Clamps	40

AFDE600/610/620 electric drive

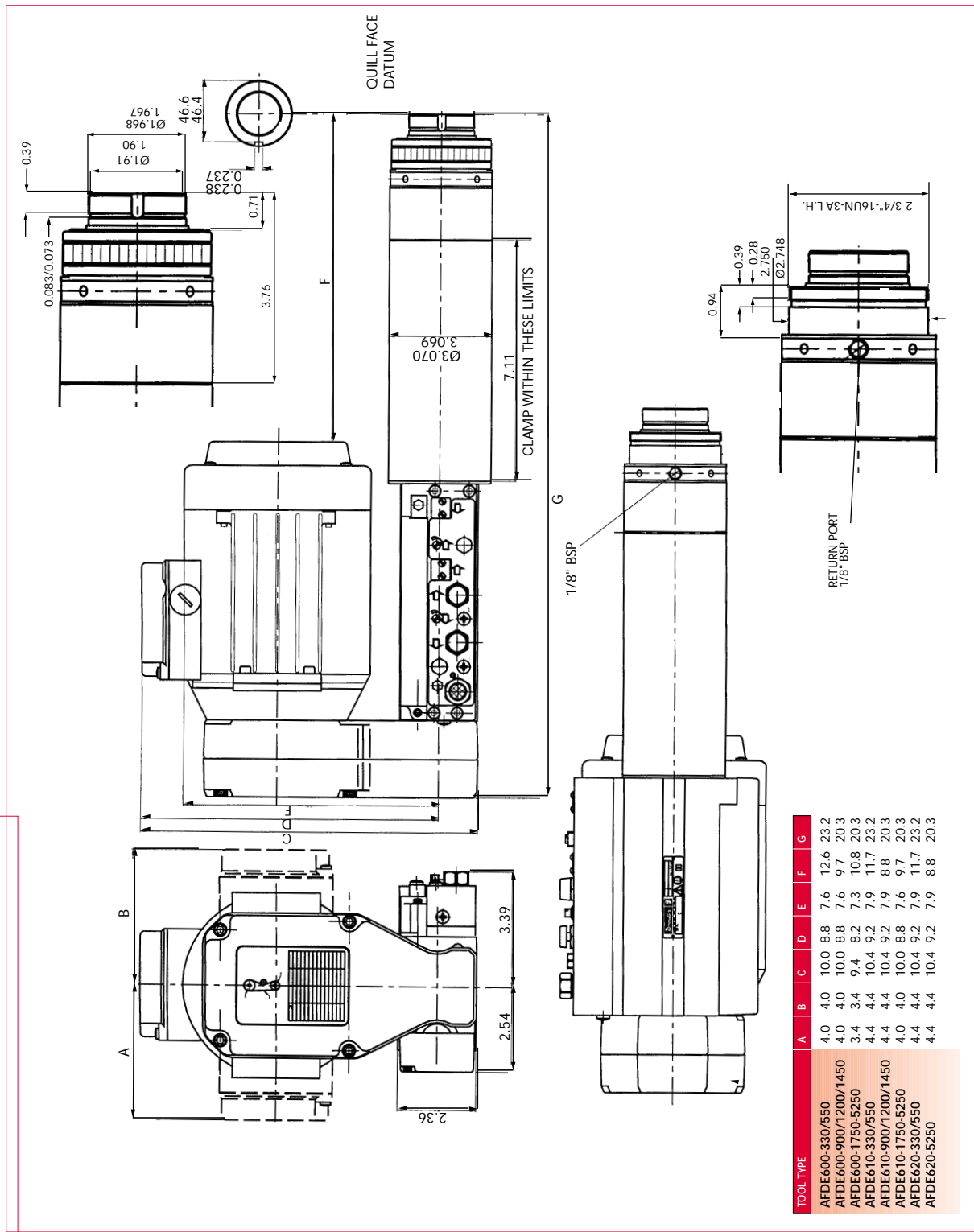



## AFDE700/AFDE710 electric drive

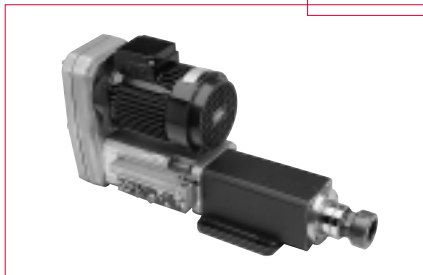

- Heavy duty drill unit
- Base mounted with cross key location
- Compact design
- Capacity up to 3/4" (20mm) in mild steel
- Hydraulic feed option available upon request to provide up to 1660 lbf (7400N) of thrust

## AFDE700

drilling performance specification

TOOL TYPE	SPEED		POWER		CURRENT		THRUST		STROKE		WEIGHT		AIR CONSUMPTION		SOUND LEVEL
	rpm		kW	HP	Amps		N	lbf	mm	ins	kg	lb	l/s <sup>2</sup>	cfm	dB(A)
model code	50Hz	60Hz	motor power		50Hz	60Hz	dynamic thrust		working stroke		weight		per cycle		
AFDE700-140	140	170	1.50	2.00	3.7	3.7	2670	600	127	5.00	63	139	<5.2	<0.19	<70
AFDE700-280	280	340	1.50	2.00	3.7	3.7	2670	600	127	5.00	63	139	<5.2	<0.19	<70
AFDE700-460	460	550	1.50	2.00	3.7	3.7	2670	600	127	5.00	63	139	<5.2	<0.19	<70
AFDE700-950	950	1140	1.50	2.00	3.7	3.7	2670	600	127	5.00	63	139	<5.2	<0.19	<70
AFDE700-1400	1400	1680	1.50	2.00	3.5	3.5	2670	600	127	5.00	63	139	<5.2	<0.19	<70
AFDE700-1900	1900	2280	1.50	2.00	3.5	3.5	2670	600	127	5.00	63	139	<5.2	<0.19	<70
AFDE700-2850	2850	3420	1.50	2.00	3.5	3.5	2670	600	127	5.00	63	139	<5.2	<0.19	<70
AFDE700-4750	4750	5700	1.50	2.00	3.5	3.5	2670	600	127	5.00	63	139	<5.2	<0.19	<70

## AFDE710

drilling performance specification

TOOL TYPE	SPEED		POWER		CURRENT		THRUST		STROKE		WEIGHT		AIR CONSUMPTION		SOUND LEVEL
	rpm		kW	HP	Amps		N	lbf	mm	ins	kg	lb	l/s <sup>2</sup>	cfm	dB(A)
model code	50Hz	60Hz	motor power		50Hz	60Hz	dynamic thrust		working stroke		weight		per cycle		
AFDE710-140	140	170	2.20	2.95	5.1	5.1	2670	600	127	5.00	63	139	<5.2	<0.19	<70
AFDE710-280	280	340	2.20	2.95	5.1	5.1	2670	600	127	5.00	63	139	<5.2	<0.19	<70
AFDE710-460	460	550	2.20	2.95	5.1	5.1	2670	600	127	5.00	63	139	<5.2	<0.19	<70
AFDE710-950	950	1140	2.20	2.95	5.1	5.1	2670	600	127	5.00	63	139	<5.2	<0.19	<70
AFDE710-1400	1400	1680	2.20	2.95	5.1	5.1	2670	600	127	5.00	63	139	<5.2	<0.19	<70
AFDE710-1900	1900	2280	2.20	2.95	5.1	5.1	2670	600	127	5.00	63	139	<5.2	<0.19	<70
AFDE710-2850	2850	3420	2.20	2.95	5.1	5.1	2670	600	127	5.00	63	139	<5.2	<0.19	<70
AFDE710-4750	4750	5700	2.20	2.95	5.1	5.1	2670	600	127	5.00	63	139	<5.2	<0.19	<70

## AFDE700/AFDE710 accessories

ACCESSORIES RANGE	PAGE
Control Blocks	28
Output Spindles	31
Multiple Spindle Heads	34

AFDE700/AFDE710 electric drive

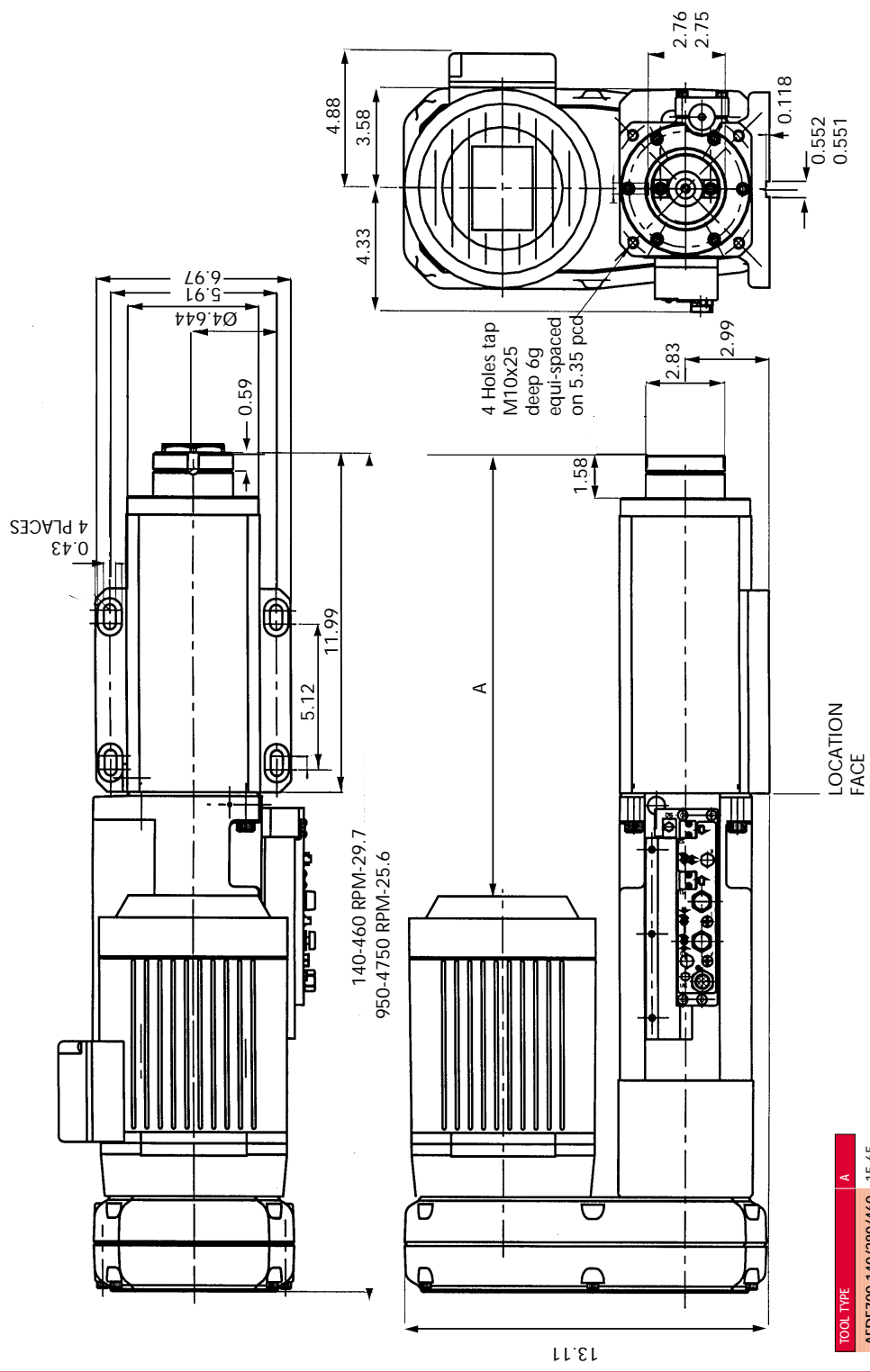

TOOL TYPE	A
AFDE700-140/280/460	15.65
AFDE700-950	11.52
AFDE700-1400-4750	12.50
AFDE710-140/280-460	15.65
AFDE710-950	11.52
AFDE710-1400-4750	11.52