

Model Codes and How to Order



5. Desoutter Inc 24415 Halstead Road Farmington Hills Michigan 48335 USA telephone +1 248 476 5358 facsimile +1 248 476 3819

Model Type – Pages 6-27

Pneumatic Feed and Drive

AFD205	0.29HP (0.22kW)
AFD215	0.29HP (0.22kW)
AFD415	0.50HP (0.38kW)
AFD/AFT60	0.70HP (0.52kW)

Pneumatic Feed, Electric Drive

AFDE200	0.33HP (0.25kW)
AFDE400	0.40HP (0.33kW)
AFDE410	1.00HP (0.75kW)
AFDE600	0.40HP (0.33kW)
AFDE610	1.00HP (0.75kW)
AFDE620	1.50HP (1.10kW)
AFDE700	2.00HP (1.50kW)
AFDE710	3.00HP (2.20kW)

Electric Feed and Drive via Leadscrew

AFTE270	0.24HP (0.18kW)
AFTE470	0.50HP (0.38kW)
AFTE480	1.00HP (0.75kW)

No Load Speed – Pages 6-27

The free output speed of the drill or tapper with no drilling or tapping load applied.

Control Block – Page 28

- A1 – Full feature type⁽¹⁾ – Automatic cycle
- A6 – Simple type⁽¹⁾⁽²⁾ – Remote cycle control
- A7 – Leadscrew type – PNP
- A8 – Leadscrew type – NPN

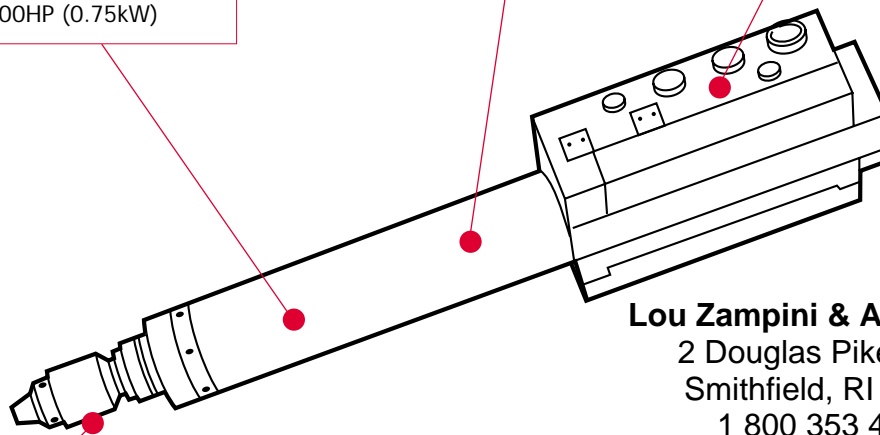

Lou Zampini & Associates

2 Douglas Pike, Rt. 7
Smithfield, RI 02917
1 800 353 4676
FAX 1 401 679 0165

Output Spindle⁽²⁾ – Pages 30/31

Output spindle to be supplied.

⁽¹⁾ Not required on AFTE models.

⁽²⁾ Does not apply for AFD60 and AFT60.

How to Order

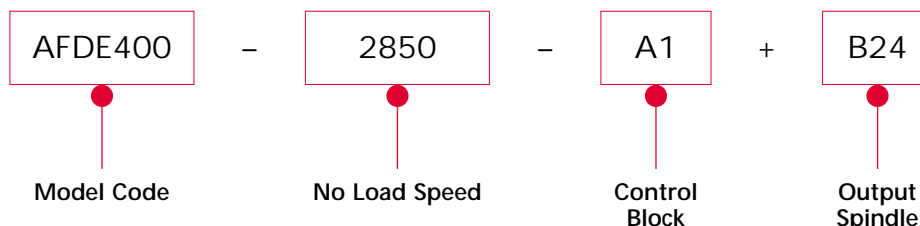



Drilling Pneumatic Drive

14. Desoutter Inc 24415 Halstead Road Farmington Hills Michigan 48335 USA telephone +1 248 476 5358 facsimile +1 248 476 3819

AFD205/AFD215 pneumatic drive

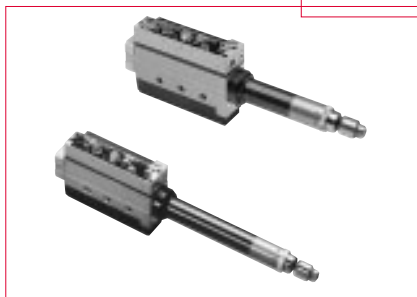

- Options of compact AFD205 or long stroke AFD215
- High thrust/size ratio
- Capacity up to 3/16" (5mm) in aluminium
- Modular output spindles

AFD205

drilling performance specification

TOOL TYPE	SPEED		POWER		THRUST		STROKE		WEIGHT		AIR CONSUMPTION		SOUND LEVEL
	rpm		kW	HP	N	lbf	mm	ins	kg	lb	l/s ²	cfm	dB(A)
model code	no load speed		motor power		dynamic thrust		working stroke		weight		continuous running		
AFD205-650	650		0.22	0.30	400	90	50	1.97	3.9	8.6	9.5	20	75
AFD205-1000	1000		0.22	0.30	400	90	50	1.97	3.9	8.6	9.5	20	75
AFD205-2700	2700		0.22	0.30	400	90	50	1.97	3.9	8.6	9.5	20	75
AFD205-4350	4350		0.22	0.30	400	90	50	1.97	3.9	8.6	9.5	20	75
AFD205-10000	10000		0.22	0.30	400	90	50	1.97	3.9	8.6	9.5	20	75
AFD205-18700	18700		0.22	0.30	400	90	50	1.97	3.9	8.6	9.5	20	75

AFD215

drilling performance specification

TOOL TYPE	SPEED		POWER		THRUST		STROKE		WEIGHT		AIR CONSUMPTION		SOUND LEVEL
	rpm		kW	HP	N	lbf	mm	ins	kg	lb	l/s ²	cfm	dB(A)
model code	no load speed		motor power		dynamic thrust		working stroke		weight		continuous running		
AFD215-650	650		0.22	0.30	400	90	90	3.54	4.2	9.2	9.5	20	75
AFD215-1000	1000		0.22	0.30	400	90	90	3.54	4.2	9.2	9.5	20	75
AFD215-2700	2700		0.22	0.30	400	90	90	3.54	4.2	9.2	9.5	20	75
AFD215-4350	4350		0.22	0.30	400	90	90	3.54	4.2	9.2	9.5	20	75
AFD215-10000	10000		0.22	0.30	400	90	90	3.54	4.2	9.2	9.5	20	75
AFD215-18700	18700		0.22	0.30	400	90	90	3.54	4.2	9.2	9.5	20	75

Drilling Pneumatic Drive



15. Desoutter Inc 24415 Halstead Road Farmington Hills Michigan 48335 USA telephone +1 248 476 5358 facsimile +1 248 476 3819

AFD205/AFD215 accessories

ACCESSORIES RANGE	PAGE
Control Blocks	28
Output Spindles	30
Multiple Spindle Heads	34
Clamps	38

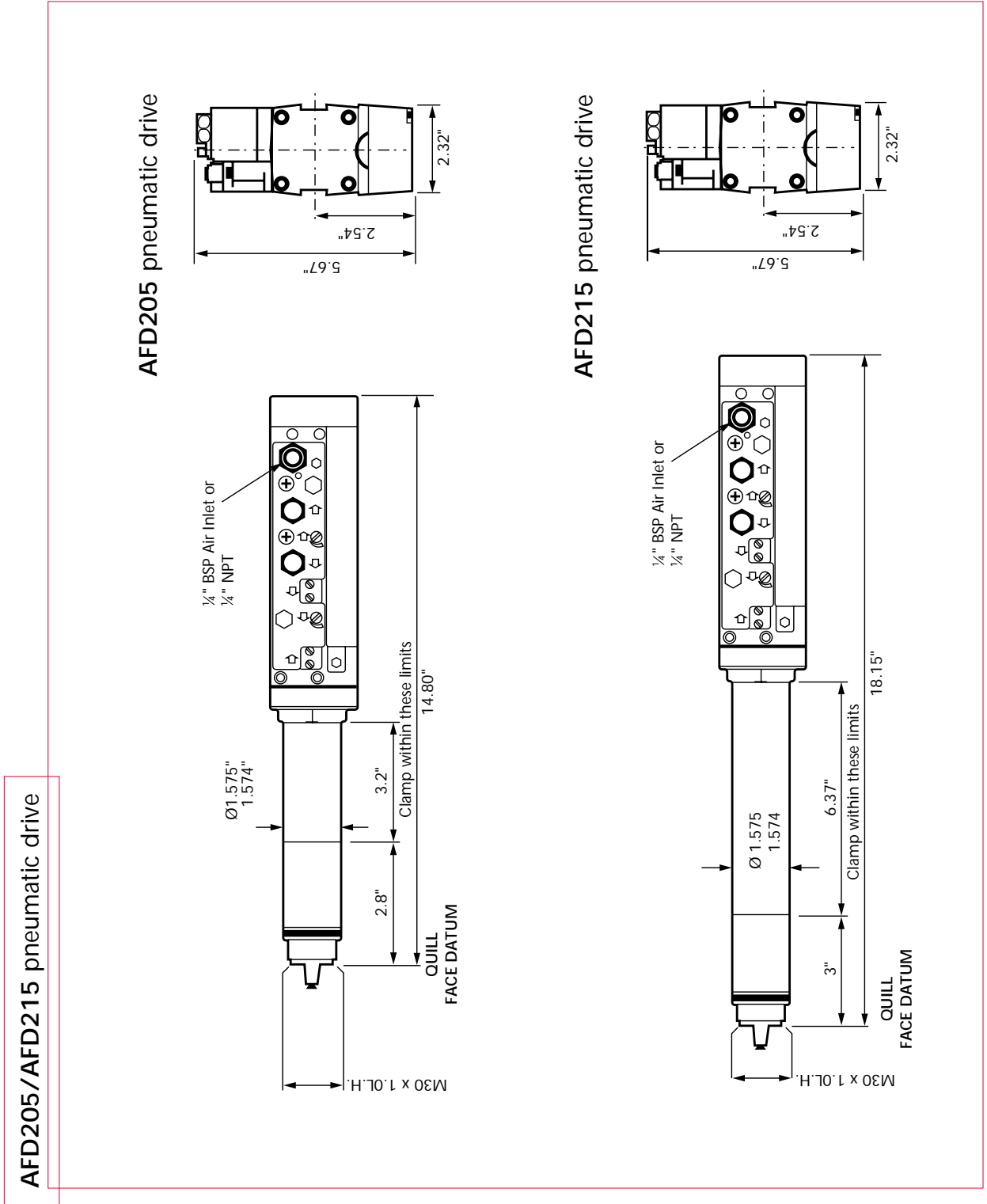



Drilling Pneumatic Drive

16. Desoutter Inc 24415 Halstead Road Farmington Hills Michigan 48335 USA telephone +1 248 476 5358 facsimile +1 248 476 3819

AFD415 pneumatic drive



- Compact unit design
- Long working stroke of 4" (100mm)
- Spindle sealed to IP64 standard
- Capacity up to 5/16" (8mm) in mild steel, 3/8" (10mm) in aluminium
- Modular output spindles

AFD415

drilling performance specification

TOOL TYPE	SPEED		POWER		THRUST		STROKE		WEIGHT		AIR CONSUMPTION		SOUND LEVEL
	rpm		kW	HP	N	lbf	mm	ins	kg	lb	l/s ²	cfm	dB(A)
model code	no load speed		motor power		dynamic thrust		working stroke		weight		continuous running		
AFD415-490	490		0.38	0.51	706	159	100	3.94	6.2	13.7	9.9	21	75
AFD415-790	790		0.38	0.51	706	159	100	3.94	6.2	13.7	9.9	21	75
AFD415-1250	1250		0.38	0.51	706	159	100	3.94	6.2	13.7	9.9	21	75
AFD415-2100	2100		0.38	0.51	706	159	100	3.94	6.2	13.7	9.9	21	75
AFD415-3400	3400		0.38	0.51	706	159	100	3.94	6.2	13.7	9.9	21	75
AFD415-5400	5400		0.38	0.51	706	159	100	3.94	6.2	13.7	9.9	21	75
AFD415-7000	7000		0.38	0.51	706	159	100	3.94	6.2	13.7	9.9	21	75
AFD415-18000	18000		0.38	0.51	706	159	100	3.94	6.2	13.7	9.9	21	75

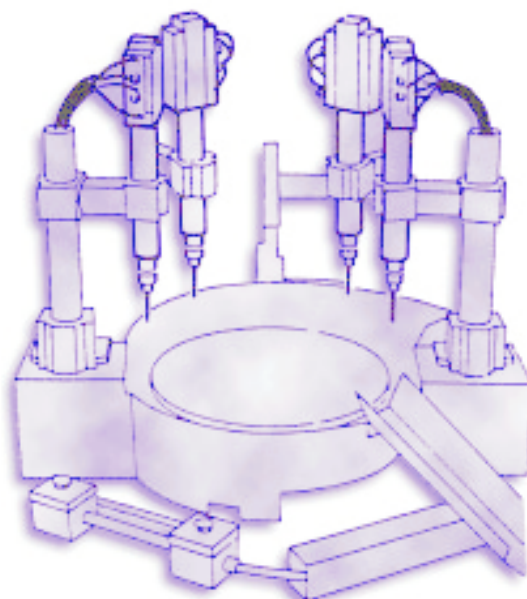

Drilling Pneumatic Drive



17. Desoutter Inc 24415 Halstead Road Farmington Hills Michigan 48335 USA telephone +1 248 476 5358 facsimile +1 248 476 3819

AFD415 accessories

ACCESSORIES RANGE	PAGE
Control Blocks	28
Output Spindles	30
Multiple Spindle Heads	34
Clamps	39

AFD415 pneumatic drive

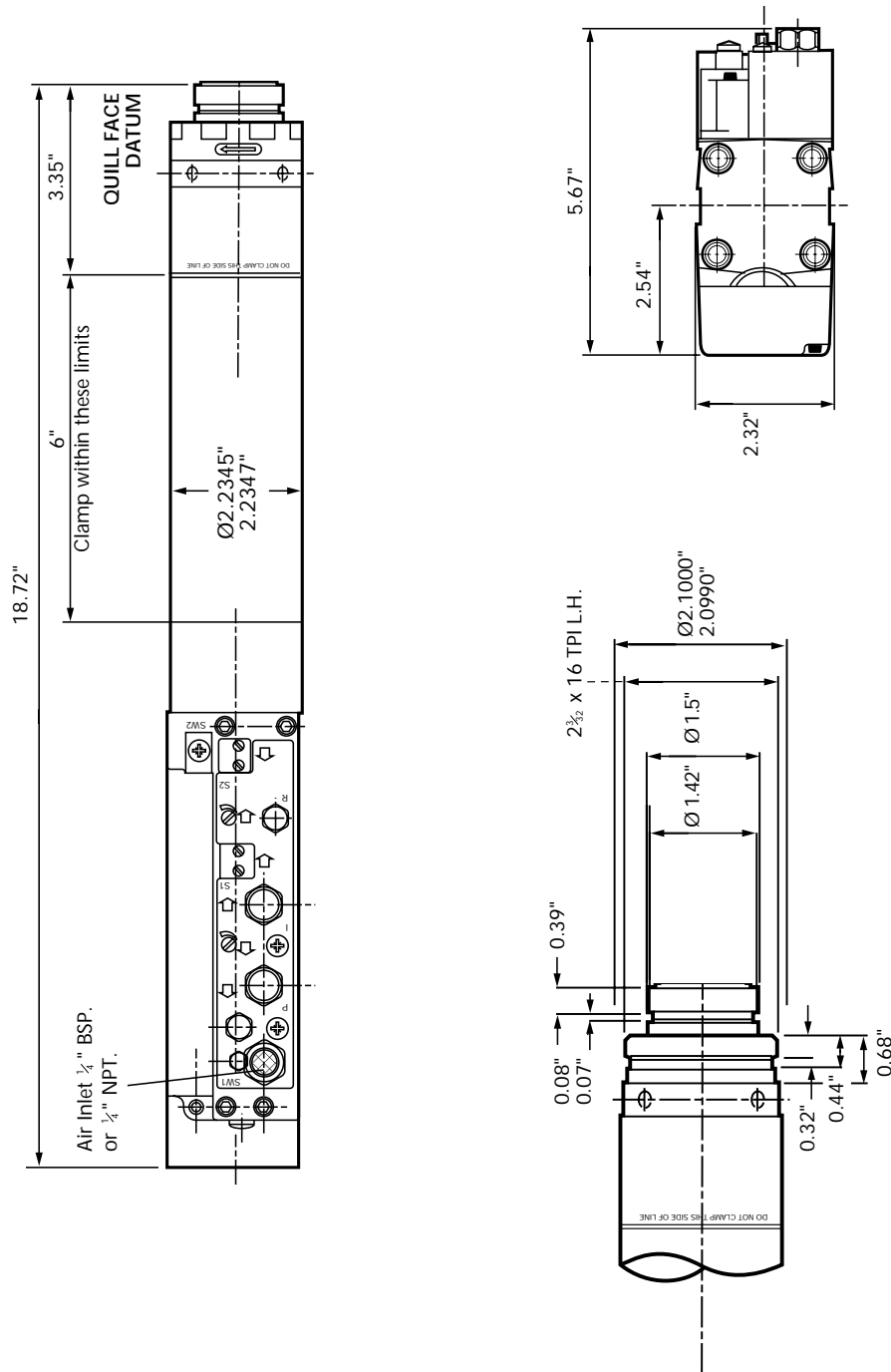



AFD Applications

4. Desoutter Inc 24415 Halstead Road Farmington Hills Michigan 48335 USA telephone +1 248 476 5358 facsimile +1 248 476 3819

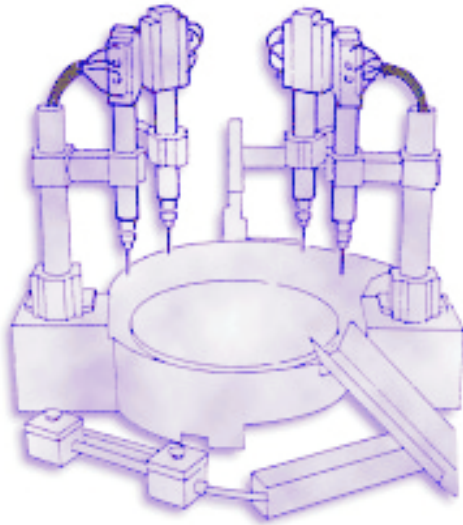

Ease of Incorporation into Machine or Process

- Extensive range of mounting clamps
- Control interfaces to link AFD(E) to other equipment through pneumatics or electrically
- Single signal required for AFD(E) to perform cycle
- Output signals at datum and depth
- Electric motor mounting on 200, 400 and 600 series can be rotated through 180°

Modular Design

- Flexibility of unit function and speed
- Common components in differing models reducing inventory
- Multiple spindle head options
- Drill and tapping options for all models

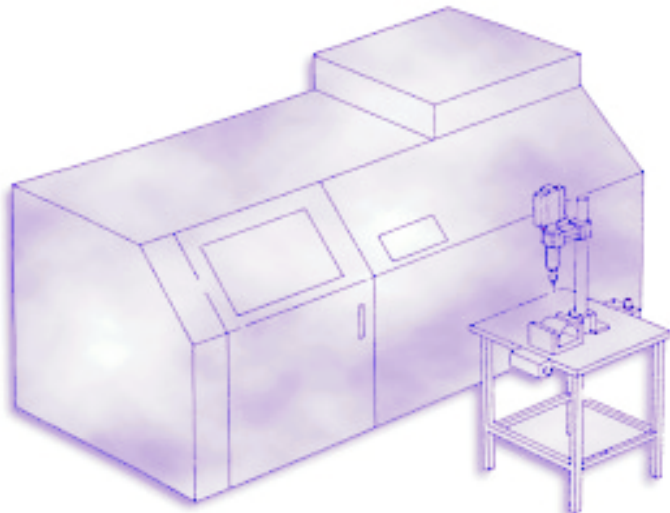
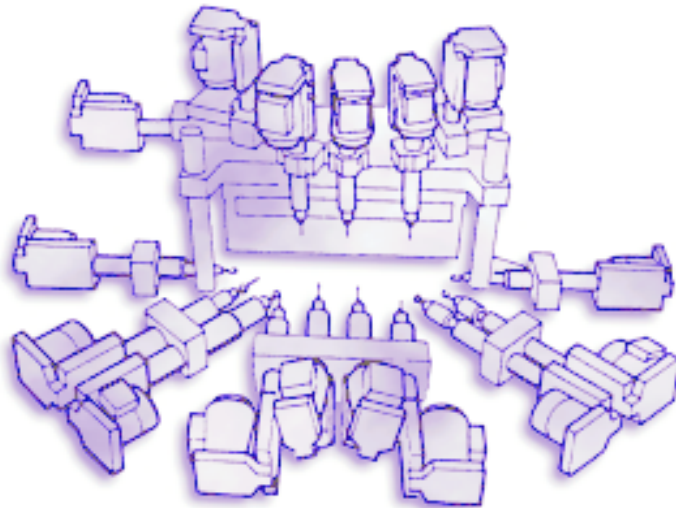

Comprehensive range of Product

- For single spindle operations to multi spindle processes
- Pneumatic and electric drive from 0.3-3.0HP (0.22 to 2.2kW) with thrusts from 72-600lbf (320 to 2670N)
- Reliability through quality