

Model Codes and How to Order



5. Desoutter Inc 24415 Halstead Road Farmington Hills Michigan 48335 USA telephone +1 248 476 5358 facsimile +1 248 476 3819

Model Type – Pages 6-27

Pneumatic Feed and Drive

AFD205	0.29HP (0.22kW)
AFD215	0.29HP (0.22kW)
AFD415	0.50HP (0.38kW)
AFD/AFT60	0.70HP (0.52kW)

Pneumatic Feed, Electric Drive

AFDE200	0.33HP (0.25kW)
AFDE400	0.40HP (0.33kW)
AFDE410	1.00HP (0.75kW)
AFDE600	0.40HP (0.33kW)
AFDE610	1.00HP (0.75kW)
AFDE620	1.50HP (1.10kW)
AFDE700	2.00HP (1.50kW)
AFDE710	3.00HP (2.20kW)

Electric Feed and Drive via Leadscrew

AFTE270	0.24HP (0.18kW)
AFTE470	0.50HP (0.38kW)
AFTE480	1.00HP (0.75kW)

No Load Speed – Pages 6-27

The free output speed of the drill or tapper with no drilling or tapping load applied.

Control Block – Page 28

- A1 – Full feature type⁽¹⁾ – Automatic cycle
- A6 – Simple type⁽¹⁾⁽²⁾ – Remote cycle control
- A7 – Leadscrew type – PNP
- A8 – Leadscrew type – NPN

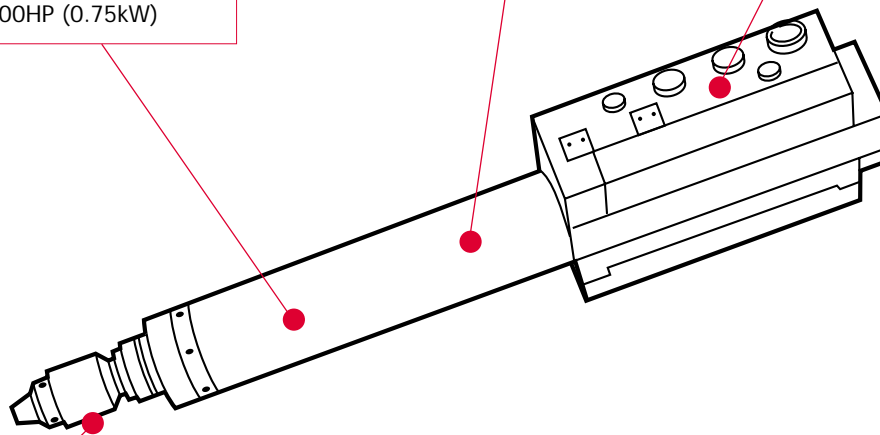

Output Spindle⁽²⁾ – Pages 30/31

Output spindle to be supplied.

⁽¹⁾ Not required on AFTE models.

⁽²⁾ Does not apply for AFD60 and AFT60.

Lou Zampini & Associates

2 Douglas Pike, Rt. 7

Smithfield, RI 02917

1 800 353 4676

FAX 1 401 679 0165

How to Order

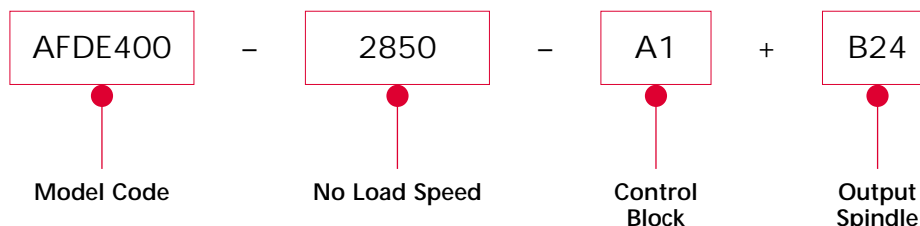

Accessories Clamps



37. Desoutter Inc 24415 Halstead Road Farmington Hills Michigan 48335 USA telephone +1 248 476 5358 facsimile +1 248 476 3819

mounting clamps



- Extensive range of mounting clamps to allow any orientation of the tool
- All clamps manufactured from aluminium

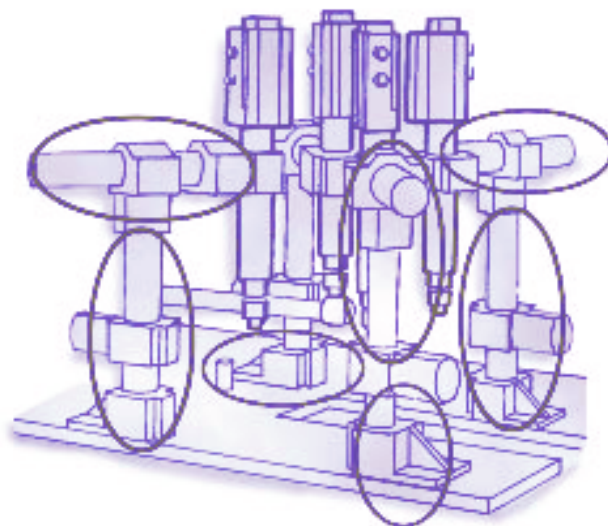
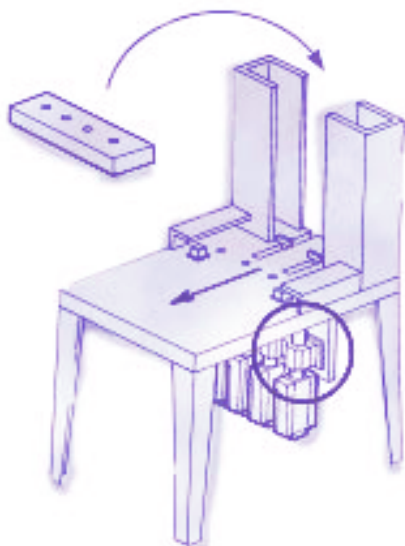
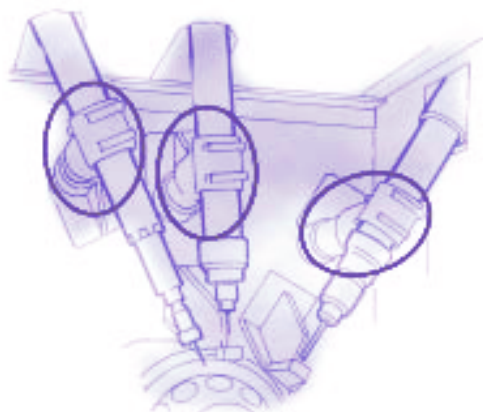



Accessories Clamps

38. Desoutter Inc 24415 Halstead Road Farmington Hills Michigan 48335 USA telephone +1 248 476 5358 facsimile +1 248 476 3819

AFD205, AFDE200, AFTE270

Parallel Clamp

Part No. 61832

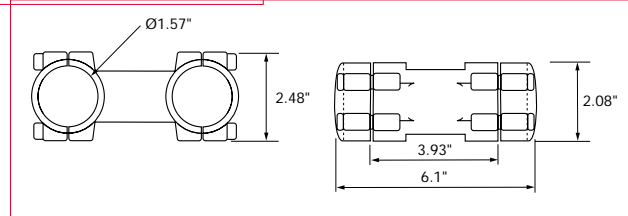

Base Clamp

Part No. 61842

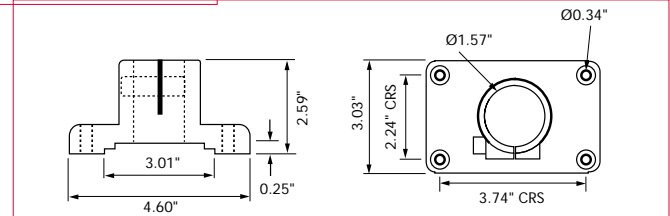

Right Angle Clamp

Part No. 61822

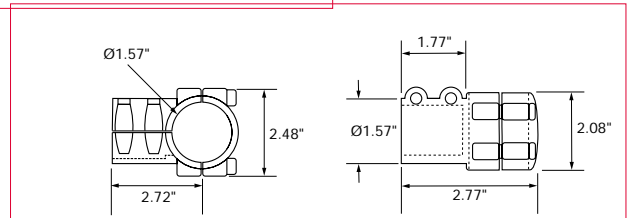

Bar Clamp

Part No. 61852

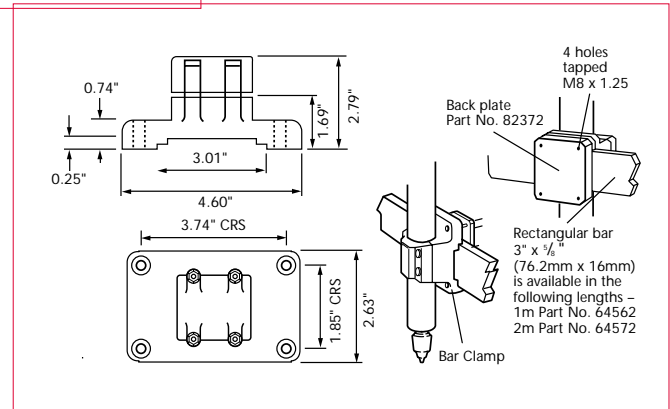

Swivel Clamp

Part No. 61802

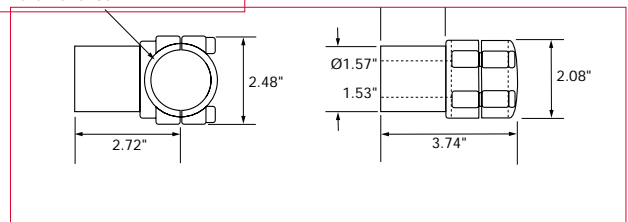

Mounting Tube

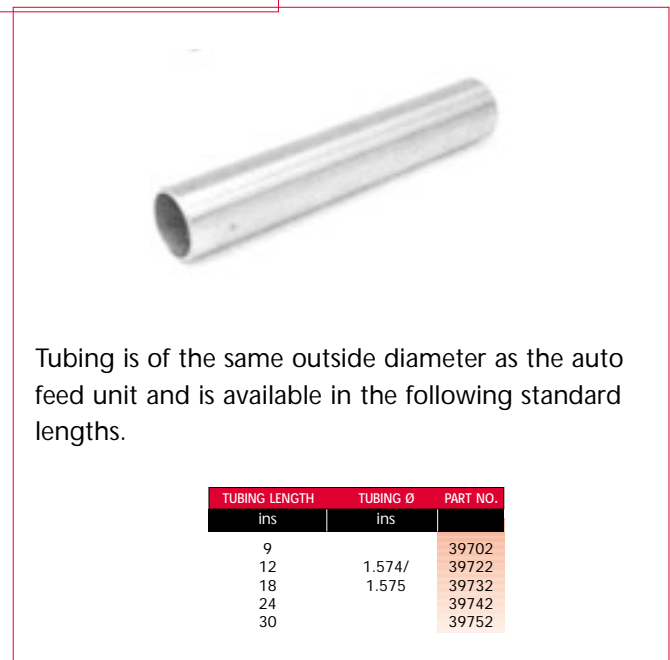

Swan Neck Clamp

Part No. 61862

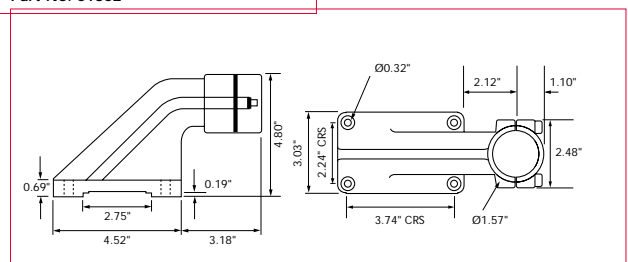

Accessories Clamps



39. Desoutter Inc 24415 Halstead Road Farmington Hills Michigan 48335 USA telephone +1 248 476 5358 facsimile +1 248 476 3819

AFD415, AFDE400/410, AFTE470/480

Parallel Clamp

Part No. 76352

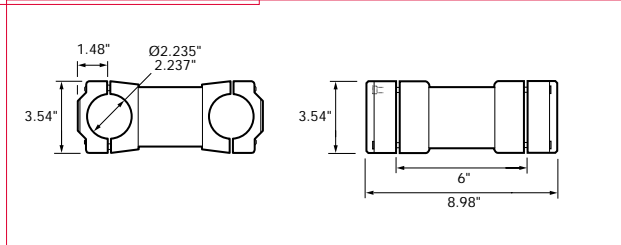

Base Clamp

Part No. 76302

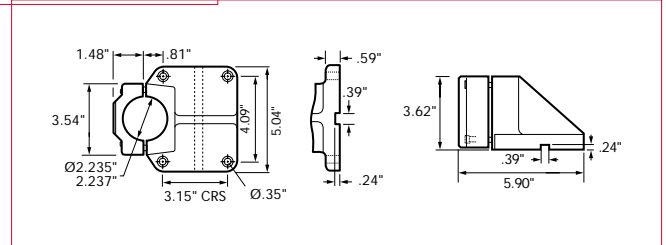

Right Angle Clamp

Part No. 76342

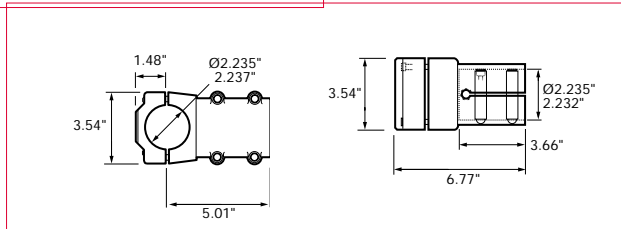

Adjustable Bar Clamp

Part No. 97042

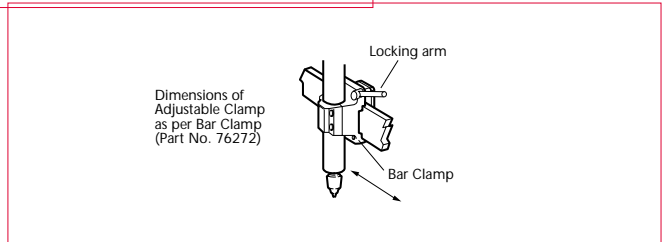

Swivel Clamp

Part No. 76332

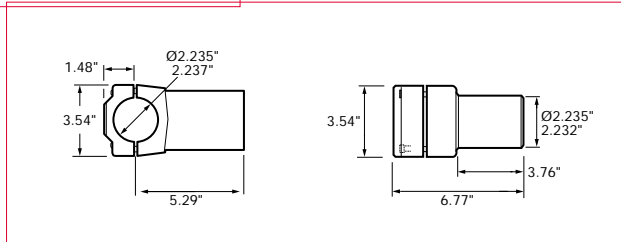

Narrow Bar Clamp

Part No. 76292

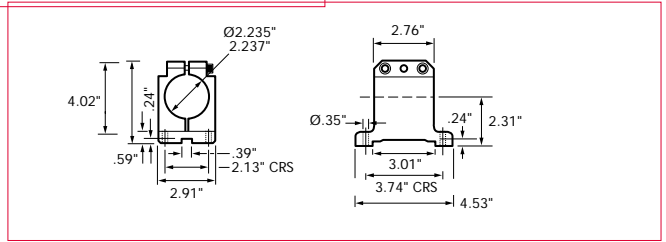

Bar Clamp

Part No. 76272

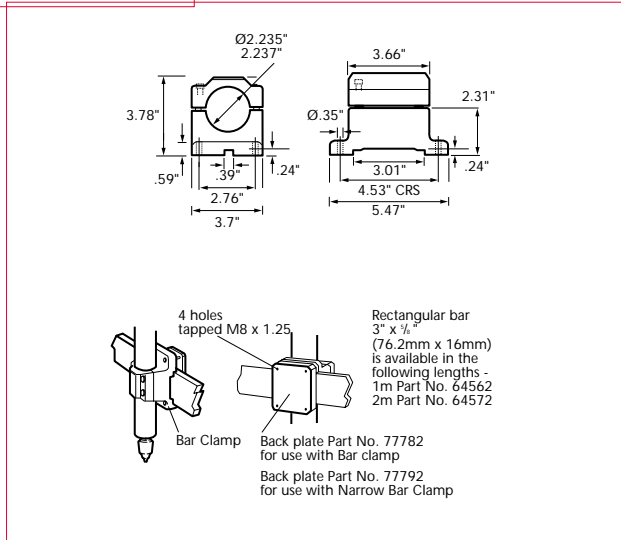

Mounting Tube

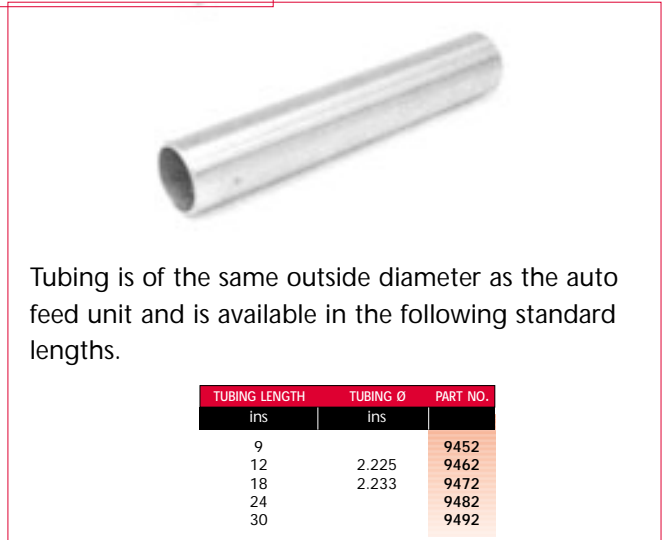



Accessories Clamps

40. Desoutter Inc 24415 Halstead Road Farmington Hills Michigan 48335 USA telephone +1 248 476 5358 facsimile +1 248 476 3819

AFD60, AFT60, AFDE600/610/620

Parallel Clamp

Part No. 32492

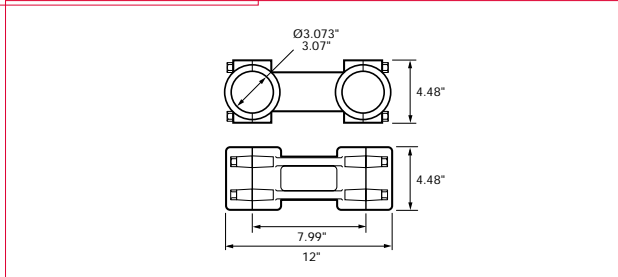

Swivel Clamp

Part No. 32502

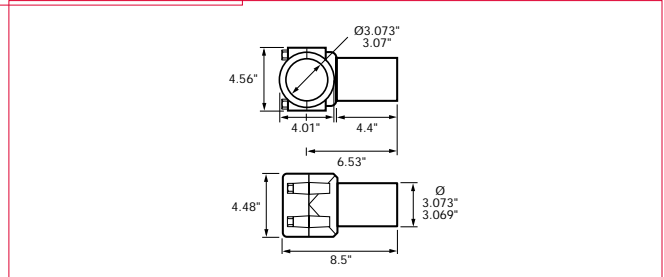

Bar Clamp

Part No. 32532

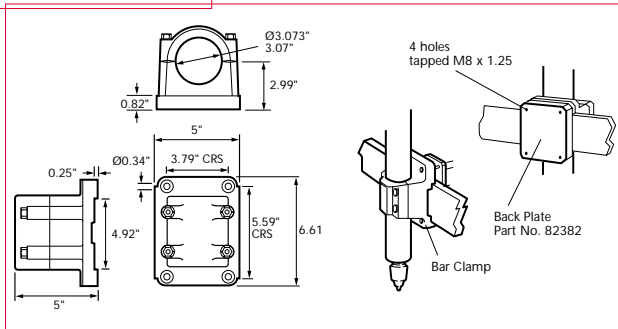

Right Angle Clamp

Part No. 32522

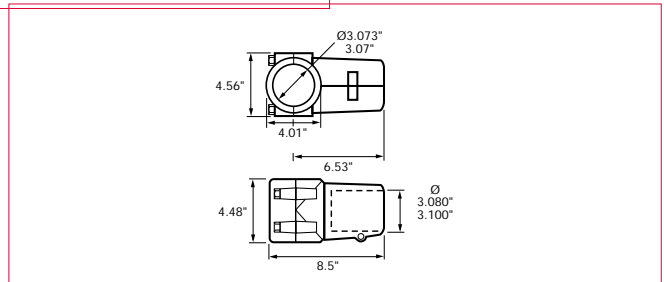

Base Clamp

Part No. 32542

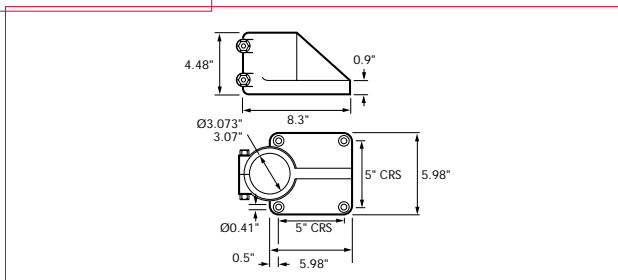

Mounting Tube



Tubing is of the same outside diameter as the auto feed unit and is available in the following standard lengths.

TUBING LENGTH	TUBING Ø	PART NO.
ins	ins	
24	3.069	32562
36		32572
48		32582