

## Product – AFD625 with Direct 2HM-5 Motor Drive

Details as follows:

- This based upon the same basic drive unit (BDU) as the AFDE600/610/620 use this for more detailed front end dimensions
- To enable a pneumatic drive a motor mounting adaptor is assembled in place of the electric pulley housing – as below

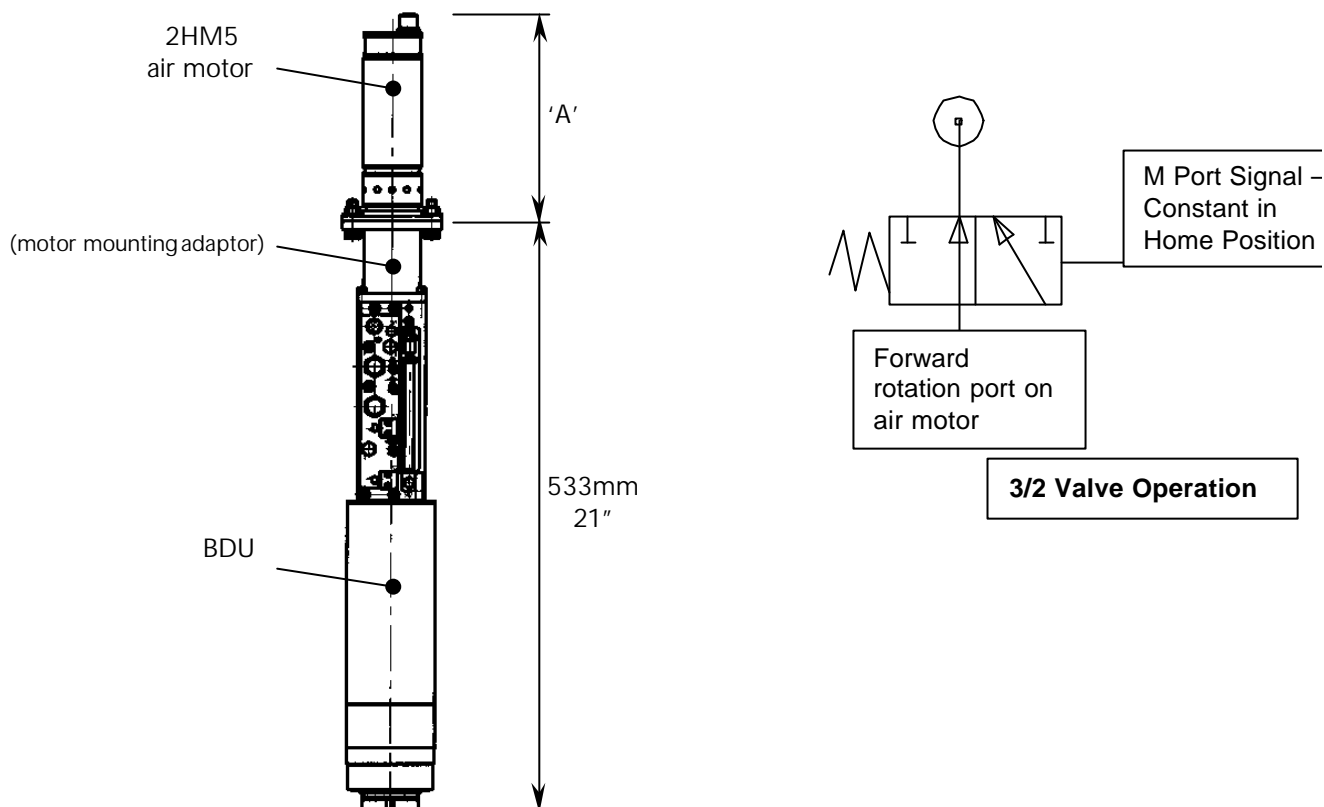

A 3/2 Valve (supplied) is required with an A1 block in order to turn the air motor off at the home position. Similarly external valves (not supplied) will be required with the A6 block.

	Speed rpm	Length 'A' (mm)
2HM5-3300	3300	143.5
2HM5-2100	2100	143.5
2HM5-950	950	187
2HM5-550	550	187
2HM5-350	350	187

	Speed rpm	Length 'A' (mm)
2HM5-150	150	224.5
2HM5-100	100	224.5
2HM5-40	40	224.5

### Lou Zampini & Associates

2 Douglas Pike, Rt. 7

Smithfield, RI 02917

1 800 353 4676

FAX 1 401 679 0165

AFD625 with direct 2HM-5 motor drive – A1 block version shown



- Medium/Heavy duty unit
- Multiple spindle head options for drilling and tapping – same as 600 series
- Modular design
- Full feature control block (simple control block optional)
- Automatic cycle with external valve to stop air motor
- Adjustable depth control
- Quill sealed to IP64

#### Type

Pneumatic Feed and Drive Drill / Tapper

#### Specification

##### NOMINAL CAPACITY IN MILD STEEL

Drilling (HSS Jobber Drill)	10 mm/ 3/8"
Tapping (Spiral Flute Bright Tap)	M10/ 3/8"-16

POWER	0.85 HP
THRUST	350lbs @ 90psi with spring return 390lbs @ 90psi with spring removed
SPEEDS	40-3300 rpm through different air motors – see 2HM5 range
NOISE LEVEL	TBA
AIR CONSUMPTION	35cfm (continuous running)
STROKE	4"
WEIGHT	TBA

#### Options – As existing AFDE600/610/620

Control Options including;	Multiple Spindle Heads
- Dwell	Mounting clamps
- Peck feed	Push-pull tapping
- Skip Drilling	Output spindles
- Hydraulic feed control	Silencer
Electric/Pneumatic interfaces	