

Model Type – Pages 6-27

Pneumatic Feed and Drive

AFD205	0.29HP (0.22kW)
AFD215	0.29HP (0.22kW)
AFD415	0.50HP (0.38kW)
AFD/AFT60	0.70HP (0.52kW)

Pneumatic Feed, Electric Drive

AFDE200	0.33HP (0.25kW)
AFDE400	0.40HP (0.33kW)
AFDE410	1.00HP (0.75kW)
AFDE600	0.40HP (0.33kW)
AFDE610	1.00HP (0.75kW)
AFDE620	1.50HP (1.10kW)
AFDE700	2.00HP (1.50kW)
AFDE710	3.00HP (2.20kW)

Electric Feed and Drive via Leadscrew

AFTE270	0.24HP (0.18kW)
AFTE470	0.50HP (0.38kW)
AFTE480	1.00HP (0.75kW)

No Load Speed – Pages 6-27

The free output speed of the drill or tapper with no drilling or tapping load applied.

Lou Zampini & Associates

2 Douglas Pike, Rt. 7
Smithfield, RI 02917

1 800 353 4676

FAX 1 401 679 0165

Control Block – Page 28

A1 – Full feature type⁽¹⁾ – Automatic cycle

A6 – Simple type⁽¹⁾⁽²⁾ – Remote cycle control

A7 – Leadscrew type – PNP

A8 – Leadscrew type – NPN

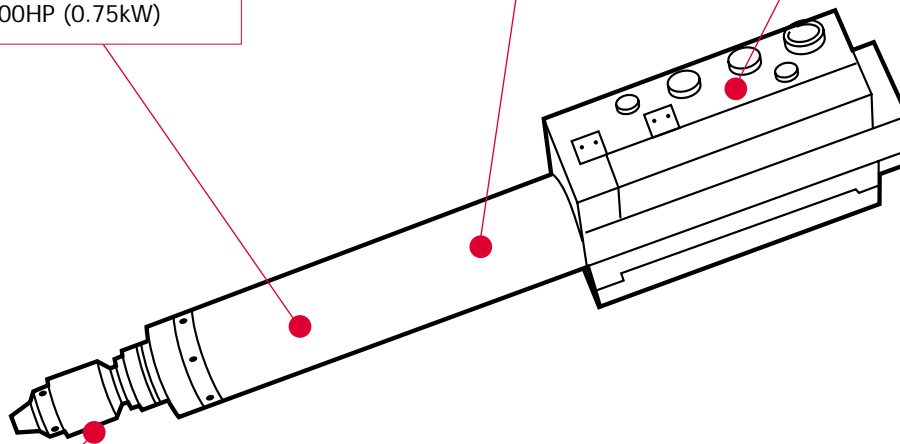

Output Spindle⁽²⁾ – Pages 30/31

Output spindle to be supplied.

⁽¹⁾ Not required on AFTE models.

⁽²⁾ Does not apply for AFD60 and AFT60.

How to Order

AFDE400

–

2850

–

A1

+

B24

Model Code

No Load Speed

Control Block

Output Spindle

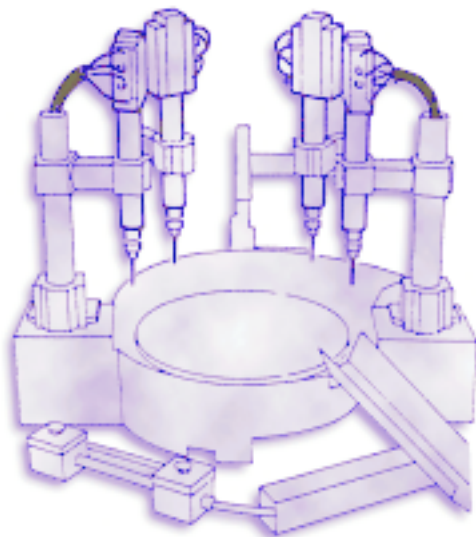

Ease of Incorporation into Machine or Process

- Extensive range of mounting clamps
- Control interfaces to link AFD(E) to other equipment through pneumatics or electrically
- Single signal required for AFD(E) to perform cycle
- Output signals at datum and depth
- Electric motor mounting on 200, 400 and 600 series can be rotated through 180°

Modular Design

- Flexibility of unit function and speed
- Common components in differing models reducing inventory
- Multiple spindle head options
- Drill and tapping options for all models

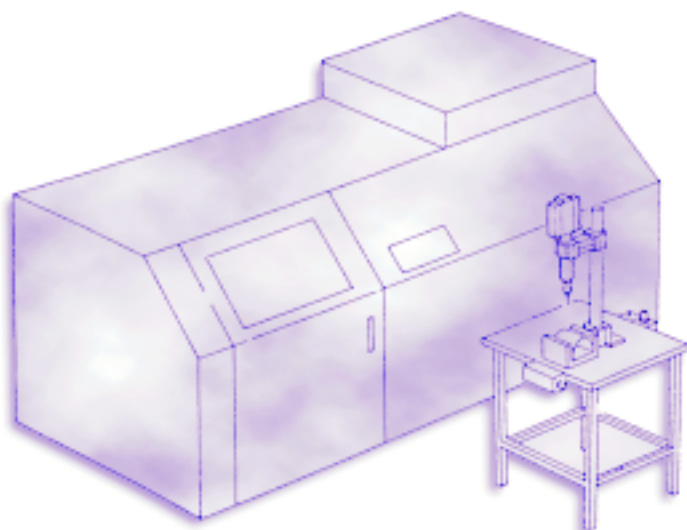
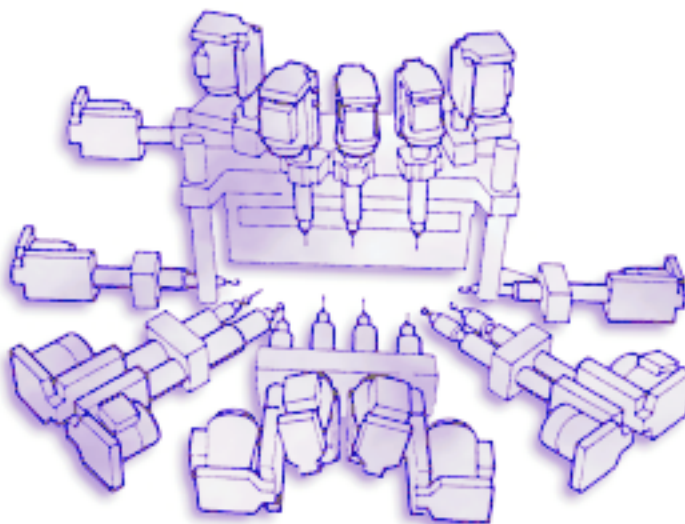

Comprehensive range of Product

- For single spindle operations to multi spindle processes
- Pneumatic and electric drive from 0.3-3.0HP (0.22 to 2.2kW) with thrusts from 72-600lbf (320 to 2670N)
- Reliability through quality



AFTE270 leadscrew



- Light duty high speed leadscrew tappers
- Features 0.24HP (0.18kW) brake motor
- Optional control box with integral PLC controller
- Supplied fitted with proximity switches for depth, datum and 'no hole' sensing, PNP or NPN
- Quick release interchangeable leadscrew and nut assembly
- Capacity up to 1/4" (6mm) in aluminium, 1/8" (3mm) in mild steel depending on thread form

AFTE270

tapping performance specification

TOOL TYPE	SPEED		POWER		CURRENT		TORQUE		STROKE		WEIGHT		SOUND LEVEL
	rpm		kW	HP	Amps		Nm	lbf ins	mm	ins	kg	lb	dB(A)
model code	50Hz	60Hz	motor power		50Hz	60Hz	tapping torque available	pitch controlled stroke		weight			
AFTE270-1100	1100	1320	0.18	0.24	0.3	0.3	1.4	12.4	70	2.76	12	26.4	<70
AFTE270-1300	1300	1560	0.18	0.24	0.3	0.3	1.1	9.7	70	2.76	12	26.4	<70
AFTE270-1850	1850	2220	0.18	0.24	0.3	0.3	0.9	8.0	70	2.76	12	26.4	<70
AFTE270-2350	2350	2820	0.18	0.24	0.3	0.3	0.7	6.2	70	2.76	12	26.4	<70
AFTE270-2950	2950	3540	0.18	0.24	0.3	0.3	0.6	5.3	70	2.76	12	26.4	<70

leadscrew/nut assemblies AFTE270

SHAPE	REPLACEMENT LEADSCREW/ NUT ONLY	ORDERING CODE	THREAD SIZE/ PITCH
	part no.		
	380373	L34	0.25
	369933	L33	0.30
	369923	L32	0.35
	359303	L31	0.40
	359293	L30	0.45
	350713	L1	0.50
	350723	L2	0.60
	350733	L3	0.70
	350743	L4	0.75
	350753	L5	0.80
	350763	L6	1.00
	402723	L38	80 TPI
	391533	L36	64 TPI
	391543	L37	56 TPI
	390333	L35	48 TPI
	350803	L10	40 TPI
	350813	L11	36 TPI
	350823	L12	32 TPI
	350833	L13	28 TPI
	350843	L14	26 TPI
	350853	L15	24TPI
	350993	L22	1/8" NPT (27 TPI)
	350923	L23	0 BA
	350933	L24	1 BA
	350943	L25	2 BA
	350953	L26	3 BA
	350963	L27	4 BA
	350973	L28	5 BA
	350983	L29	6BA

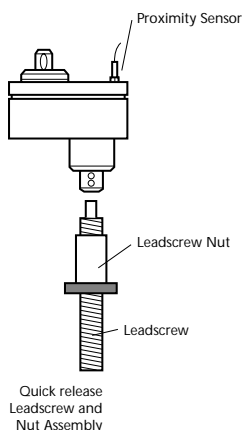

Other leadscrews available to special order.

AFTE270 control box

USA 220/480V Part No. 105062
 Europe 380/415V Part No. 105052



Proximity switches included with tool.

Control Blocks
 A7 – PNP Switches
 A8 – NPN Switches

AFTE270 accessories

ACCESSORIES RANGE	PAGE
Output Spindles	30
Multiple Spindle Heads	34
Clamps	38

AFTE270 leadscrew

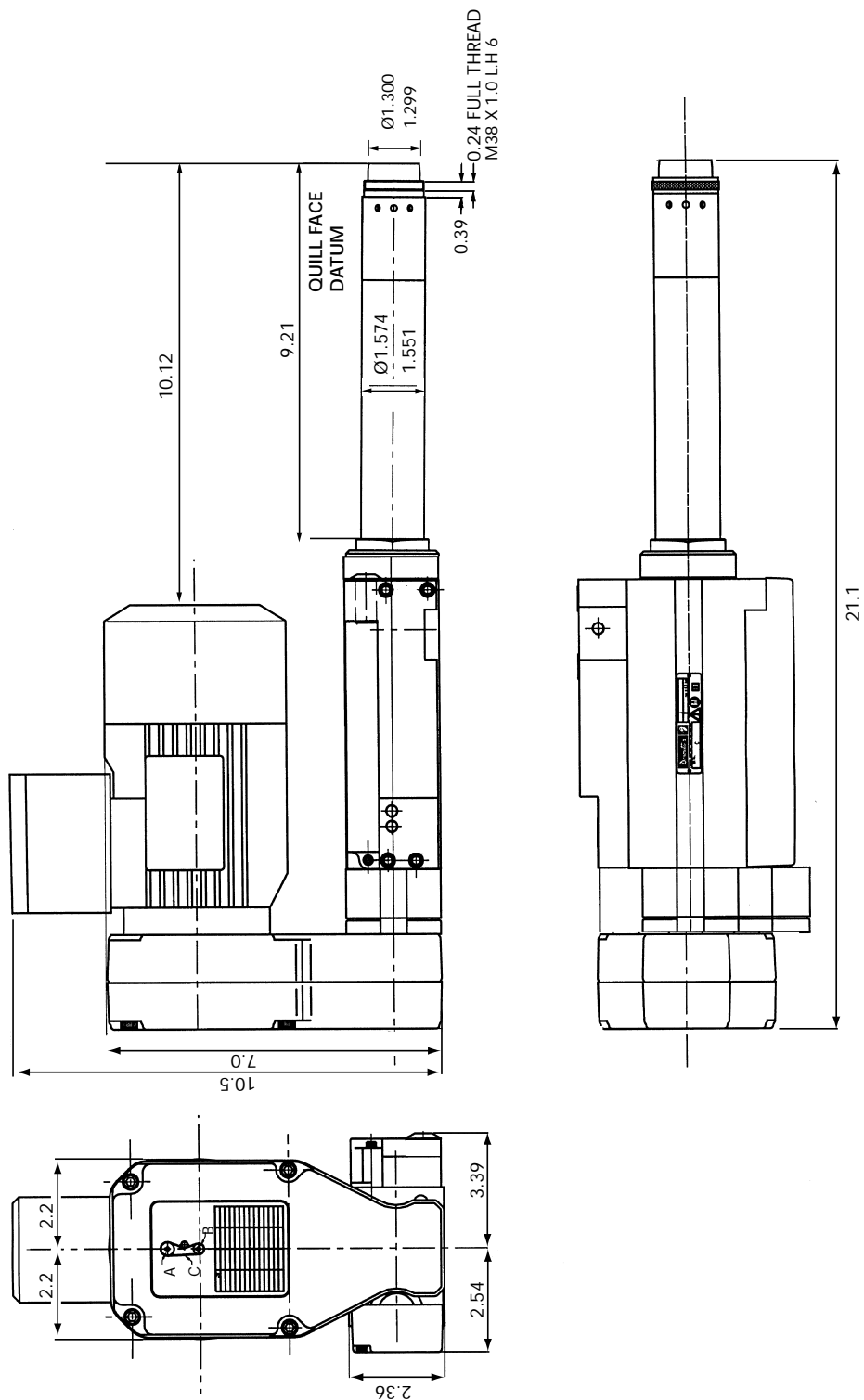



AFTE470/AFTE480 leadscrew



- High power brake motors with options of 0.50HP (0.38kW) or 1.00HP (0.75kW)
- Optional control box with integral PLC controller
- Supplied fitted with proximity switches for depth, datum and 'no hole' sensing, PNP or NPN
- Quick release interchangeable leadscrew and nut assembly
- Capacity up to 3/8" (10mm) in mild steel, 5/8" (16mm) in aluminium depending on thread form

AFTE470

tapping performance specification

TOOL TYPE	SPEED		POWER		CURRENT		TORQUE		STROKE		WEIGHT		SOUND LEVEL
	rpm		kW	HP	Amps		Nm	lbf ins	mm	ins	kg	lb	
model code	50Hz	60Hz	motor power		50Hz	60Hz	tapping torque available		pitch controlled stroke		weight		
AFTE470-180	180	215	0.38	0.50	1.05	1.05	17.9	158.4	70	2.76	25	55	<70
AFTE470-330	330	400	0.38	0.50	1.05	1.05	9.8	86.4	70	2.76	25	55	<70
AFTE470-550	550	660	0.38	0.50	1.05	1.05	5.9	51.8	70	2.76	25	55	<70
AFTE470-900	900	1080	0.38	0.50	1.05	1.05	3.6	31.7	70	2.76	25	55	<70
AFTE470-1200	1200	1440	0.38	0.50	1.05	1.05	2.7	23.8	70	2.76	25	55	<70
AFTE470-1450	1450	1740	0.38	0.50	1.05	1.05	2.2	19.7	70	2.76	25	55	<70

AFTE480

tapping performance specification

TOOL TYPE	SPEED		POWER		CURRENT		TORQUE		STROKE		WEIGHT		SOUND LEVEL
	rpm		kW	HP	Amps		Nm	lbf ins	mm	ins	kg	lb	
model code	50Hz	60Hz	motor power		50Hz	60Hz	tapping torque available		pitch controlled stroke		weight		
AFTE480-180	180	215	0.75	1.00	2.0	2.0	35.8	316.8	70	2.76	26.5	58.3	<70
AFTE480-330	330	400	0.75	1.00	2.0	2.0	19.5	172.8	70	2.76	26.5	58.3	<70
AFTE480-550	550	660	0.75	1.00	2.0	2.0	11.7	103.7	70	2.76	26.5	58.3	<70
AFTE480-900	900	1080	0.75	1.00	2.0	2.0	7.2	63.4	70	2.76	26.5	58.3	<70
AFTE480-1200	1200	1440	0.75	1.00	2.0	2.0	5.4	47.5	70	2.76	26.5	58.3	<70
AFTE480-1450	1450	1740	0.75	1.00	2.0	2.0	4.4	39.3	70	2.76	26.5	58.3	<70

leadscrew/nut assemblies AFTE470/480

SHAPE	REPLACEMENT LEADSCREW/NUT ONLY			REPLACEMENT LEADSCREW/NUT ONLY		
	part no.	ORDERING CODE	THREAD SIZE/PITCH	part no.	ORDERING CODE	THREAD SIZE/PITCH
<p>Quick release Leadscrew and Nut Assembly</p>	380373	L34	0.25	350823	L12	32 TPI
	369933	L33	0.30	350833	L13	28 TPI
	369923	L32	0.35	350843	L14	26 TPI
	359303	L31	0.40	350853	L15	24 TPI
	359293	L30	0.45	350863	L16	22 TPI
	350713	L1	0.50	350873	L17	20 TPI
	350723	L2	0.60	350883	L18	19 TPI
	350733	L3	0.70	350893	L19	18 TPI
	350743	L4	0.75	350903	L20	16 TPI
	350753	L5	0.80	350913	L21	14 TPI
	350763	L6	1.00	402793	L39	12 TPI
	350773	L7	1.25	350993	L22	1/8" NPT (27 TPI)
	350783	L8	1.50			
	350793	L9	1.75	350923	L23	0 BA
	402723	L38	80 TPI	350933	L24	1 BA
	391533	L36	64 TPI	350943	L25	2 BA
	391543	L37	56 TPI	350953	L26	3 BA
	390333	L35	48 TPI	350963	L27	4 BA
	350803	L10	40 TPI	350973	L28	5 BA
350813	L11	36 TPI	350983	L29	6 BA	

Other leadscrews available to special order.

AFTE470/480 control box

USA 220/480V Part No. 105062
Europe 380/415V Part No. 105052



Proximity switches included with tool.

Control Blocks
A7 – PNP Switches
A8 – NPN Switches

AFTE470/AFTE480 accessories

ACCESSORIES RANGE	PAGE
Output Spindles	30
Multiple Spindle Heads	34
Clamps	39

AFTE470/AFTE480 leadscrew

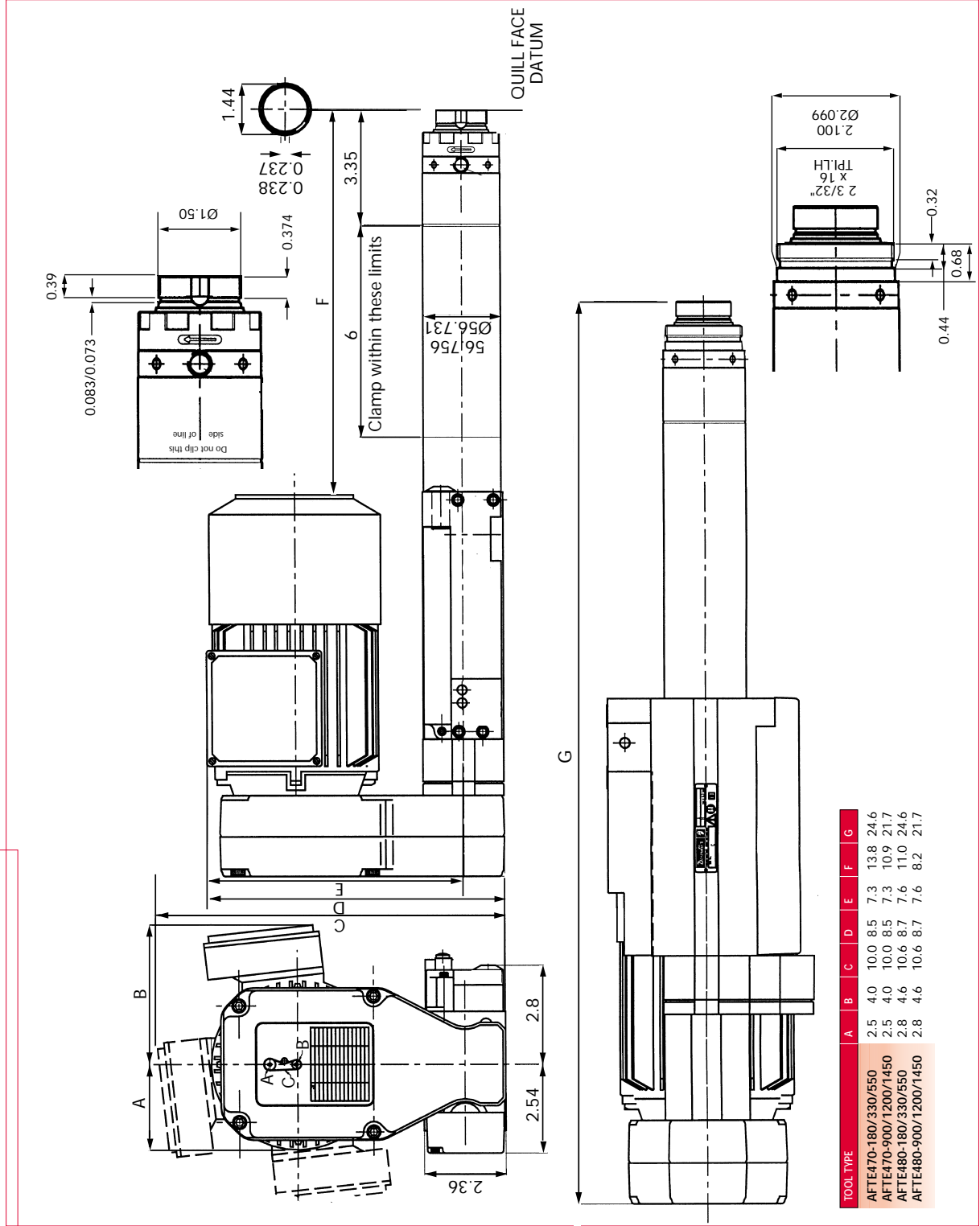

TOOL TYPE	A	B	C	D	E	F	G
AFTE470-180/330/550	2.5	4.0	10.0	8.5	7.3	13.8	24.6
AFTE470-900/1200/1450	2.5	4.0	10.0	8.5	7.3	10.9	21.7
AFTE480-180/330/550	2.8	4.6	10.6	8.7	7.6	11.0	24.6
AFTE480-900/1200/1450	2.8	4.6	10.6	8.7	7.6	8.2	21.7