

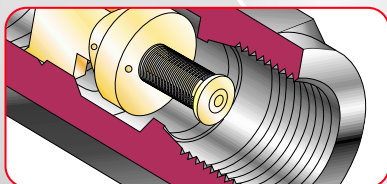

## Air Line Equipment



**Lou Zampini & Associates**  
2 Douglas Pike, Rt. 7  
Smithfield, RI 02917  
1 800 353 4676  
FAX 1 401 679 0165

# Air Line Network

Air dryers, filters and receives can cause a 0.2 - 0.3 bar pressure drop. However, for many applications these may be essential.

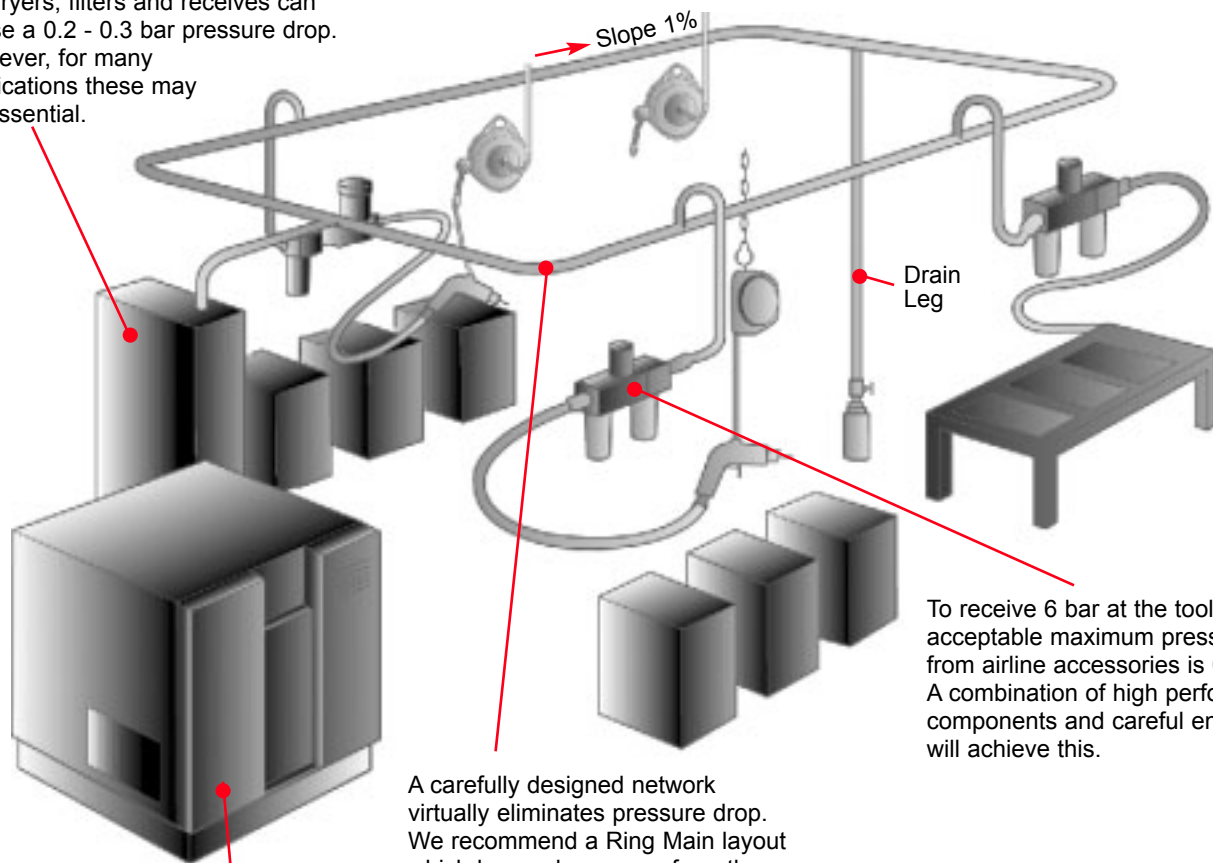

A normal compressor can deliver up to 7.5 bar air line pressure, depending on start and stop settings.

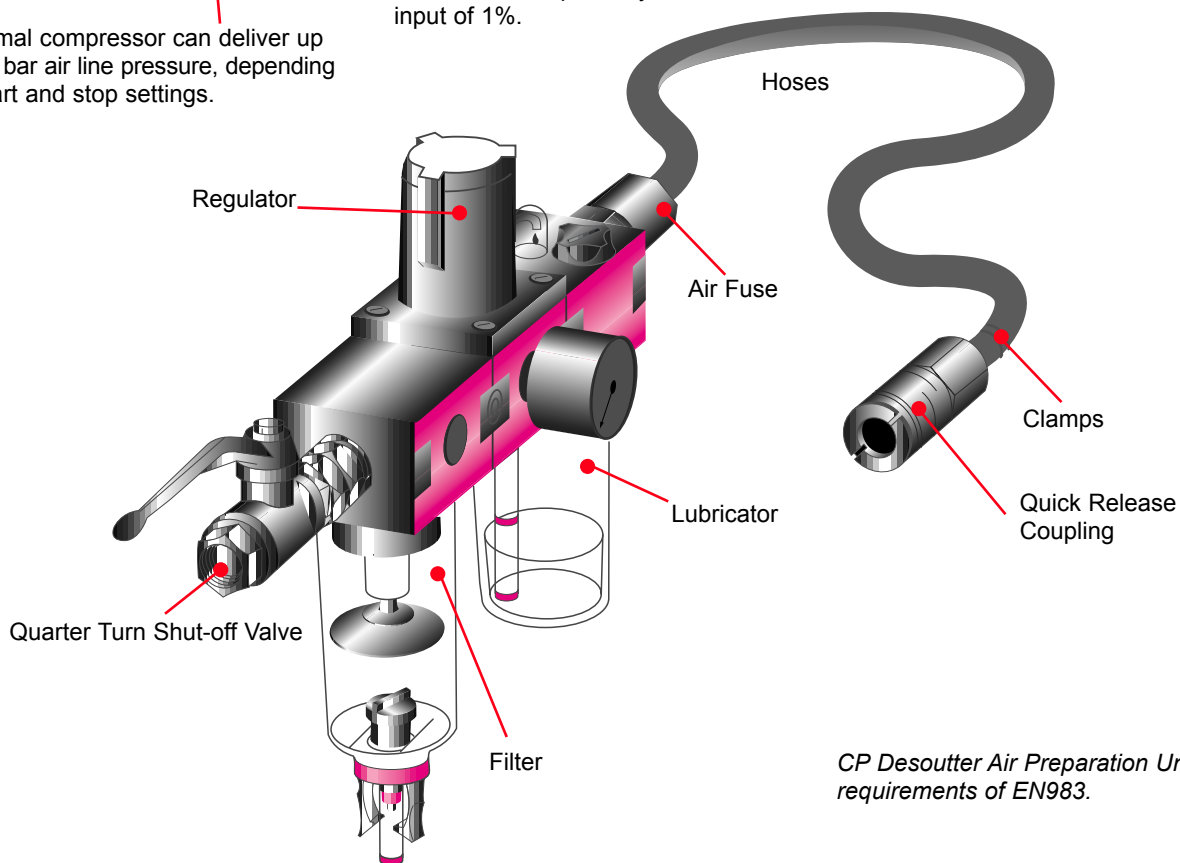

# Spiral Hoses

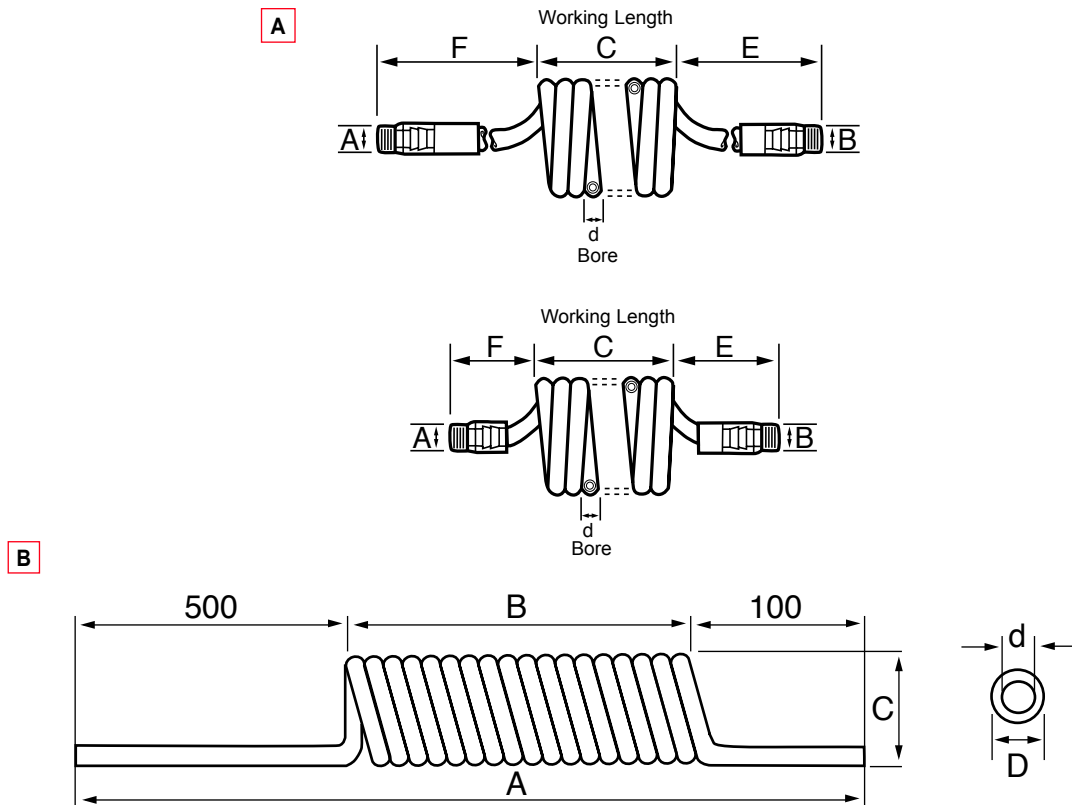

## ASSEMBLED SPIRAL HOSES

PICTURE REF	HOSE BORE d	A THREAD	B THREAD	C WORKING LENGTH	F	E	PART NUMBER
	mm	BSP	BSP	metre	mm	mm	
A	6.5	1/4	1/4	2	400	400	96832
A	6.5	1/4	1/4	4	400	400	96852
A	6.5	1/4	1/4	3	0	0	98072
A	6.5	1/4	1/4	4	0	0	98082
A	8.5	1/4	1/4	5	0	0	98092
A	8.5	3/8	3/8	5	0	0	98102
A	6	1/8	1/4	1.5	500	200	99922
A	6	1/4	1/4	1.5	500	200	99932
A							
A							
A							
A							

## SELF ASSEMBLY SPIRAL HOSES

PICTURE REF	HOSE BORE d	D	WORKING LENGTH	A	B	C	PART NUMBER
	mm	mm	metre	mm	mm	mm	mm
B	6.5	10.0	2.5	785	185	52	102852
B	6.5	10.0	5	1000	400	52	102862
B	6.5	10.0	7.5	1235	635	52	102872
B	8.0	12.0	2.5	780	180	65	102892
B	8.0	12.0	5.0	990	390	65	102902

Can be used with barb and nut couplings and nipples, see page 6.

Material: Polyurethane (PUR)  
Colour: Blue

Temperature range: -40°C to +80°C  
Max. working pressure at 20°C: 10 bar (hose only)  
When hose is assembled with any end fittings, design working pressure = 6.3 bar

# Reinforced Hoses and Hose Fittings

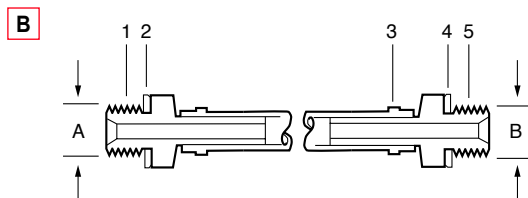
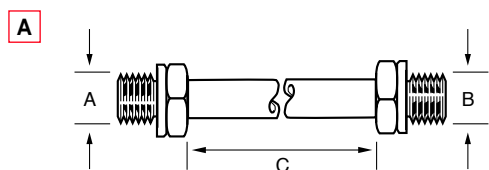

Close the lugs firmly with a pair of O-Clip pincers

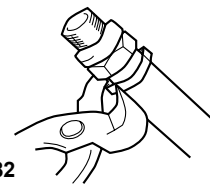

'O'-Clip pincers  
- Part No. 77282

## ASSEMBLED HOSE

PICTURE REF	HOSE BORE	HOSE OUTSIDE DIAMETER	LENGTH C	MALE THREADS		WORKING PRESSURE (AT 20°C)	TEMPERATURE RANGE	PART NUMBER
	mm	mm		A	B			
			metre	BSP	BSP	bar	°C	
A	5	6	2	M5 x 1/8"		6.3	-15 to +50	79322
A	5	6	2	1/8" x 1/4"		6.3	-15 to +50	75902
A	5	6	3	1/8" x 1/4"		6.3	-15 to +50	75922
A	6	8	3	1/4" x 1/4"		6.3	-15 to +50	75942
A	6	8	5	1/4" x 1/4"		6.3	-15 to +50	75952
A	10	14	3	1/4" x 1/4"		6.3	-15 to +60	75972
A	10	14	5	1/4" x 1/4"		6.3	-15 to +60	75982
A	6	8	3	1/8" x 1/4"		6.3	-15 to +50	104552
A	13	18	3	3/8" x 3/8"		6.3	-15 to +60	78532
A	13	18	3	1/2" x 1/2"		6.3	-15 to +60	76002
A	13	18	5	1/2" x 1/2"		6.3	-15 to +60	76022

## SELF ASSEMBLY HOSE

PICTURE REF	HOSE BORE	HOSE OUTSIDE DIAMETER	MAXIMUM WORKING PRESSURE (AT 20°C)	TEMPERATURE RANGE	PART NUMBER
	mm	mm	bar	°C	
A	5	8.5	25	-15 to +60	271393
A	6	10.5	18	-15 to +60	271403
A	10	14	13	-15 to +60	271413
A	12	17	11	-15 to +60	271423

Hose only available in lengths of 10m or multiples thereof.

## FITTINGS FOR SELF ASSEMBLY HOSE

PICTURE REF	HOSE BORE	HOSE OUTSIDE DIAMETER	1 CONNECTOR A		2 WASHER	3 'O' CLIP (2-OFF)	4 WASHER	5 CONNECTOR B	
			BSP	part no.	part no.	part no.	part no.	BSP	part no.
B	5	8-11	1/8"	271303	271533	271483	271543	1/4"	271313
B	6	13-15	1/4"	271323	271543	271493	271543	1/4"	271323
B	10	9-11	1/4"	271333	271543	271503	271543	1/4"	271333
B	12	15-18	1/2"	271343	271553	271513	271553	1/2"	271343

For quick release couplings and nipples see page 6.

## RUBBER ALLOY (RUBBER/PVC) HOSE

HOSE BORE	HOSE OUTSIDE DIAMETER	SUPPLIED LENGTH	PART NUMBER
mm	mm	metre	
10	18	30	11702
12.5	22	30	11722

Smooth bore. Excellent corrosion, chemical and abrasive resistance.

Working pressure at 20°C: 20 bar (hose only). Temperature range: -30°C to +70°C

When hose is assembled with any end fittings, design working pressure = 6.3 bar

# Claw Couplings/Quarter Turn Shut-off Valves

Claw Couplings are an efficient way of connecting hoses where maximum possible air flow is required. Recommended for use with rubber hose only.

A

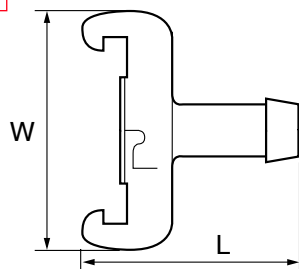

W = 57mm  
L = 69mm

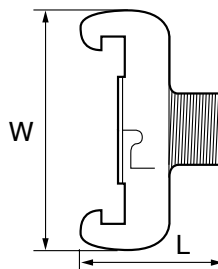

W = 57mm  
L = see table

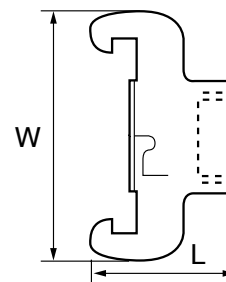

W = 57mm  
L = see table

## MATERIALS

Body	Embossed brass
Seal	Black rubber

Note: Manufactured to French NF E29573 Standard

## CLAW COUPLINGS – EUROPEAN STYLE

PICTURE REF	HOSE INTERNAL Ø	THREAD	HOSE STEM	MALE THREAD		FEMALE THREAD	
				L	L	L	L
	mm	BSP	part no.	mm	part no.	mm	part no.
A	7	1/4"	109712	40	109772	32	109832
A	8	3/8"	109722	40	109782	32	109842
A	10	1/2"	109732	41	109792	32	109852
A	13	3/4"	109742	41	109802	36	109862
A	16	1"	109752	44	109822	36	109872
A	19	-	109762	-	-	-	-

Max. Pressure: 10 bar

## QUARTER TURN SHUT-OFF VALVES

Designed for operation fully open or fully closed only

### MATERIALS

1	Body	Brass – Nickel plated
2	Body End	Brass
3	Ball	Brass – Chrome plated
4	Seats	P.T.F.E.
5	O-Ring	Viton
6	O-Ring	NBR
7	Stem	Brass
8	Lever	Steel
9	Screw	Steel

B

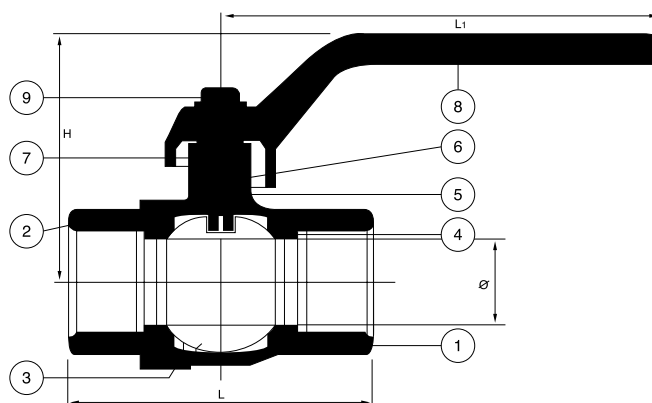

PICTURE REF	THREAD	WEIGHT	BORE Ø	DIMENSIONS			PART NUMBER
				L	H	L <sub>1</sub>	
	BSP	kg	mm	mm	mm	mm	
B	1/4"	0.17	8	45	47	81	109882
B	3/8"	0.17	10	45	47	81	109892
B	1/2"	0.22	15	59	55	105	109902
B	3/4"	0.36	20	69	66	120	109922
B	1"	0.57	25	83	70	120	109932
B	1 1/4"	0.87	32	94	83	135	109942
B	1 1/2"	1.14	40	102	93	160	109952

Working temperature range: -30°C to +200°C

Max. working pressure: 40 bar



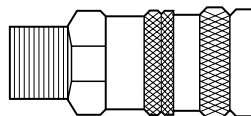

# Quick Release Couplings

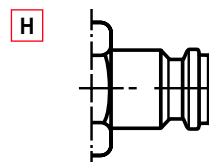
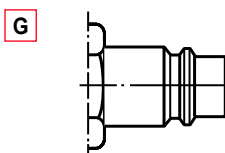
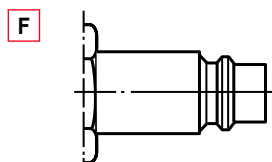
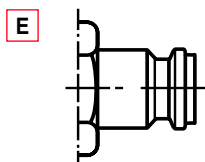





**A** **B** **C** **D**



## COUPLINGS

PICTURE REF	FLOW AT 6 BAR (87 psi)	SIZE		DESCRIPTION	MALE THREAD 	FEMALE THREAD 	BARBED 	BARB AND NUT 
		l/s	mm					
A	10		1/4" BSP	Several German types	-	9092009391	-	-
B	18	6	1/4"	310 Series/US Industrial Standard MIL C 4109	-	-	9092009871	-
B	18	8	5/16"	310 Series/US Industrial Standard MIL C 4109	-	-	9092009901	-
B	18	10	3/8"	310 Series/US Industrial Standard MIL C 4109	-	-	9092009931	-
B	18		1/4" BSP	310 Series/US Industrial Standard MIL C 4109	-	9092009481	-	-
B	18		3/8" BSP	310 Series/US Industrial Standard MIL C 4109	-	9092009511	-	-
B	18		1/2" BSP	310 Series/US Industrial Standard MIL C 4109	9092009451	-	-	-
B	18	8 x 12 hose		310 Series/US Industrial Standard MIL C 4109	-	-	-	9092010021
C	35	6	1/4"	320 Series/Euro Standard	-	-	9092009181	-
C	35	8	5/16"	320 Series/Euro Standard	-	-	9092013091	-
C	35	10	3/8"	320 Series/Euro Standard	-	-	9092009211	-
C	35	13	1/2"	320 Series/Euro Standard	-	-	9092009241	-
C	35		1/4" BSP	320 Series/Euro Standard	9092008911	9092008821	-	-
C	35		3/8" BSP	320 Series/Euro Standard	9092008941	9092008861	-	-
C	35		1/2" BSP	320 Series/Euro Standard	9092008971	9092008881	-	-
C	35	6.5 x 10 hose		320 Series/Euro Standard	-	-	-	9092010131
C	35	8 x 12 hose		320 Series/Euro Standard	-	-	-	9092010161
D	64		1/2" BSP	410 Series	9092010401	9092013181	-	-

## NIPPLES

PICTURE REF	FLOW AT 6 BAR (87 psi)	SIZE		DESCRIPTION	MALE THREAD 	FEMALE THREAD 	BARBED 	BARB AND NUT 
		l/s	mm					
E	10		1/4" BSP	Several German types	9092009841	-	-	-
F	18	8	5/16"	310 Series/US Industrial Standard MIL C 4109	-	-	9092009571	-
F	18	10	3/8"	310 Series/US Industrial Standard MIL C 4109	-	-	9092009601	-
F	18		1/8" BSP	310 Series/US Industrial Standard MIL C 4109	9092009691	-	-	-
F	18		1/4" BSP	310 Series/US Industrial Standard MIL C 4109	9092009721	9092009781	-	-
F	18		3/8" BSP	310 Series/US Industrial Standard MIL C 4109	9092009751	9092009811	-	-
F	18	8 x 12 hose		310 Series/US Industrial Standard MIL C 4109	-	-	-	9092009661
G	35	6	1/4"	320 Series/Euro Standard	-	-	9092009271	-
G	35	8	5/16"	320 Series/Euro Standard	-	-	9092010221	-
G	35	10	3/8"	320 Series/Euro Standard	-	-	9092009301	-
G	35	13	1/2"	320 Series/Euro Standard	-	-	9092009331	-
G	35		1/8" BSP	320 Series/Euro Standard	9092013061	-	-	-
G	35		1/4" BSP	320 Series/Euro Standard	9092009091	9092009001	-	-
G	35		3/8" BSP	320 Series/Euro Standard	9092009121	9092009031	-	-
G	35		1/2" BSP	320 Series/Euro Standard	9092009151	9092009061	-	-
G	35	6.5 x 10 hose		320 Series/Euro Standard	-	-	-	9092010281
G	35	8 x 12 hose		320 Series/Euro Standard	-	-	-	9092010311
H	64		1/4" BSP	410 Series	9092013331	9092013391	-	-
H	64		3/8" BSP	410 Series	9092013361	-	-	-
H	64		1/2" BSP	410 Series	9092010461	9092013421	-	-

# Air Fuses

An Air Fuse reduces the likelihood of potentially dangerous hose whip caused when a hose bursts or a fitting becomes detached. Air Fuses quickly shut off the supply and reset automatically as soon as back pressure in the line downstream is restored.

Air Fuses help to meet OSHA requirement 1926.302 (USA) and may eliminate the need for restraining or shielding hose, as required by European Standard EN983.

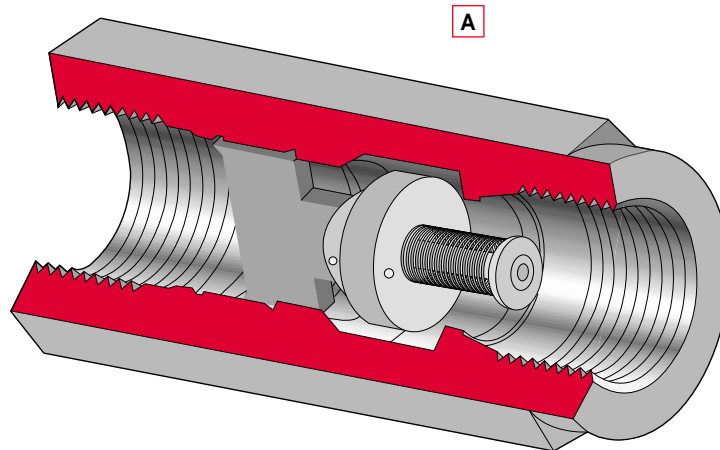

## MATERIALS

Body	Anodised aluminium
Internal parts	Brass
Spring	Stainless steel

## AIR FUSES

- Reduces risk of hose whip, helping to protect personnel
- Simple and reliable design
- High life expectancy
- Aluminium anodised body for high corrosion resistance
- Auto-Reset to restart downstream activity with the minimum downtime

PICTURE REF	PORT SIZE	PRESSURE DROP AT SHUT OFF FLOW		SHUT OFF FLOW RATE AT 7 BAR		TOOL MAXIMUM AIR FLOW		FOR FLOW RATES		PART NUMBER
		bar	l/s	l/s	l/s	High	Low			
A	1/4"	0.14	7.80	5		✓			110392	
A	1/4"	0.30	13.0	10		✓			110402	
A	3/8"	0.14	18.0	10			✓		110422	
A	3/8"	0.30	32.2	25		✓			110432	
A	1/2"	0.30	45.0	35		✓			110442	
A	3/4"	0.30	75.0	60		✓			110452	
A	1"	0.30	86.0	70		✓			110462	

Operating pressure: Maximum - 16 bar; Minimum - According to the hose length

Operating temperature: -20°C to +80°C

**NB:** Above data is a guide only. Selection of the correct Air Fuse depends on tool flow rate and hose length. Please call one of our representatives for further assistance.

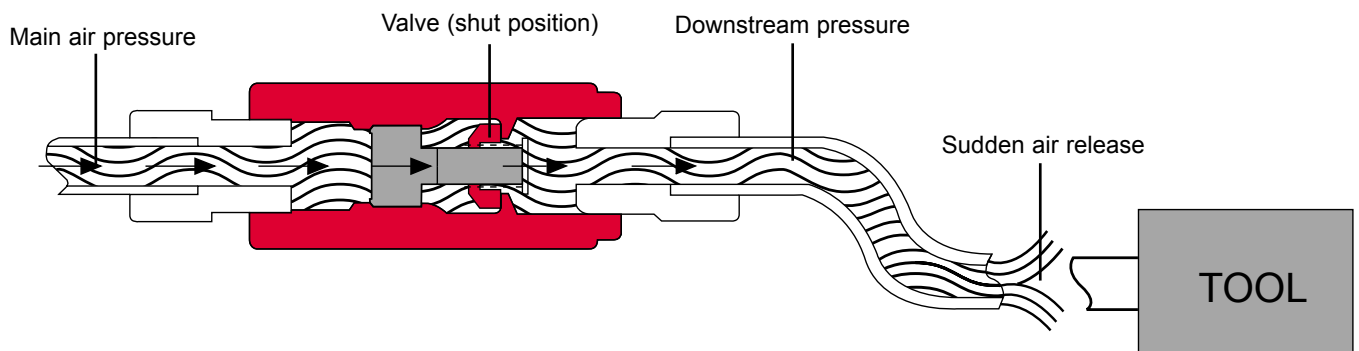

# Adaptors and Threaded Fittings

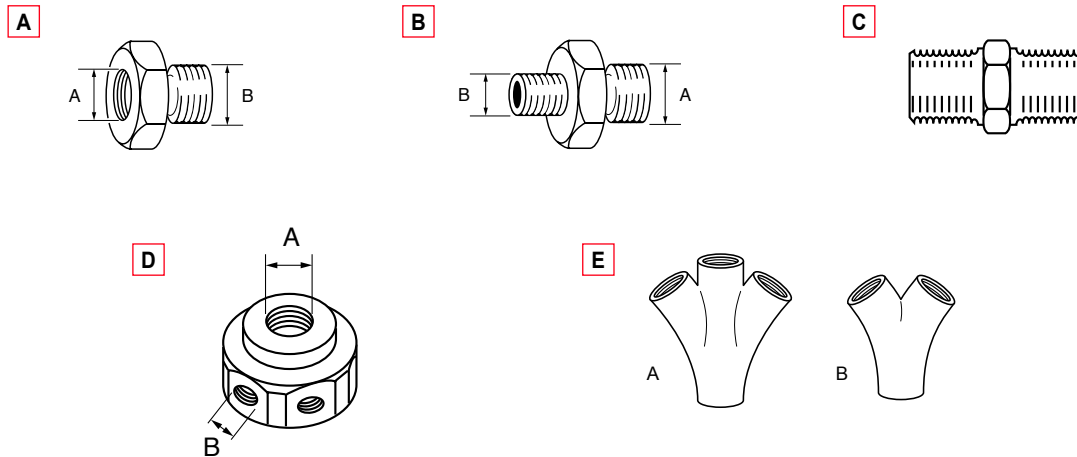

## REDUCERS

PICTURE REF	A	B	part no.
A	M5	1/8" BSP	257013
A	1/8" BSP	1/4" BSP	62972
A	1/4" NPT	1/4" BSP	181523
A	3/8" BSP	3/8" NPT	464723
A	1/2" BSP	1/2" NPT	464733
A	1/8" NPT	1/8" BSP	61103
A	3/8" BSP	1/2" BSP	62992
A	1/2" BSP	3/4" BSP	63792
A	1/8" BSP	1/8" NPT	271463
A	1/4" BSP	1/8" BSP	209843

## MALE THREAD REDUCER

PICTURE REF	A	B	part no.
B	1/4" BSP	1/8" BSP	101062
B	3/8" BSP	1/4" BSP	101072
B	1/2" BSP	3/8" BSP	101082
B	1/4" BSP	1/4" NPT	104532

## CONNECTORS

PICTURE REF	BSPT SIZE	part no.
C	1/4"	48693
C	3/8"	48703

## DISTRIBUTOR BLOCK

PICTURE REF	A	B	part no.
D	3/4"	1/4"	54493

## ADAPTOR

PICTURE REF	SIZE	A	B
		part no.	part no.
E	3/8" BSP	-	100032
E	1/2" BSP	98662	100042



# Adaptors and Threaded Fittings

A

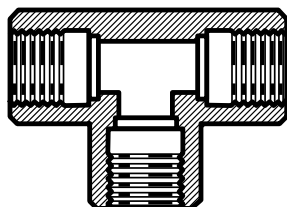

B

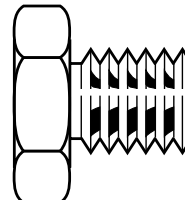

C

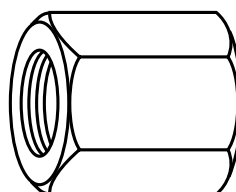

## EQUAL TEE

PICTURE REF	BSP SIZE	part no.
A	1/4"	63802
A	3/8"	63822

## BLANKING PLUG

PICTURE REF	BSP SIZE	part no.
B	1/4"	63022

## DOUBLE FEMALE SLEEVE

PICTURE REF	BSP SIZE	part no.
C	1/8"	64472
C	1/4"	62962

# Air Preparation Units – Combination Sets

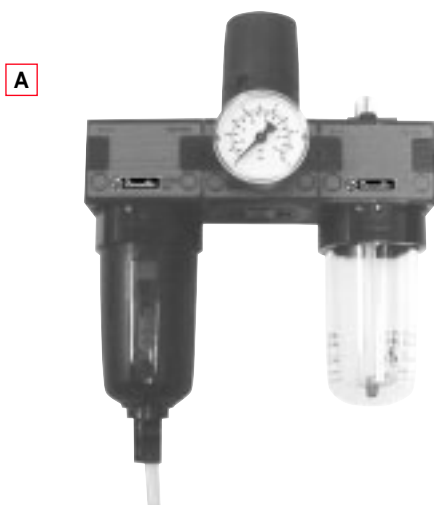

## TECHNICAL SPECIFICATIONS

### FILTER, REGULATOR, LUBRICATOR

- Air Preparation unit comprising:

Filter-Water Separator, Pressure Regulator with gauge, Oil Mist Lubricator, Mounting Bracket

Separate Regulators are recommended where high accuracy of working pressure (eg. on fastening tools) is required.

PICTURE REF	FILTER, REGULATOR AND LUBRICATOR	PORT SIZE
		1/2"
A	Recommended Flow at 6 bar (l/s)	37
	Operating Pressure Range (bar)	0/16
	Outlet Pressure min/max (bar)	0,5/8
	Condensate Capacity max (cl)	5.7
	Moisture Separation at recommended flow (%)	95
	Oil Capacity max (cl)	12
	Oil Refill	Manual – also possible with pressure on Degressive (drops/min remains constant)
	Oil/Air Ratio	All sizes: 30
	Filter, Standard – white (µm)	All sizes: 5 (see page 11)
	Option – yellow (µm)	

### FILTER/REGULATOR, LUBRICATOR

- Air Preparation unit comprising:

Filter/Regulator with gauge, Oil Mist Lubricator, Mounting Bracket

Filter/regulators are recommended where preventing overspeed of a tool due to high air pressure is required.

PICTURE REF	FILTER/REGULATOR AND LUBRICATOR	PORT SIZE			
		1/4"	3/8"	1/2"	1"
B	Recommended Flow at 6 bar (l/s)	9	14	37	83
	Operating Pressure Range (bar)	0/16	0/16	0/16	0/10
	Outlet Pressure min/max (bar)	0,5/8	0,5/8	0,5/8	0,5/10
	Condensate Capacity max (cl)	2.2	5.7	5.7	50
	Moisture Separation at recommended flow (%)	95	95	95	96
	Oil Capacity max (cl)	4.5	12	12	50
	Oil Refill	Manual – also possible with pressure on Degressive (drops/min remains constant)			
	Oil/Air Ratio	All sizes: 30			
	Filter, Standard – white (µm)	All sizes: 5 (see page 11)			
	Option – yellow (µm)				

## ORDERING TABLE

PICTURE REF	FILTER DRAIN	PORT SIZE 1/4"	FILTER DRAIN	PORT SIZE 3/8"	FILTER DRAIN	PORT SIZE 1/2"	FILTER DRAIN	PORT SIZE 1"
		part no.		part no.		part no.		part no.
A	–	–	–	–	Semi-Auto	109262	–	–
B	Semi-Auto	109082	Semi-Auto	109152	Semi-Auto	109242	Semi-Auto	109292
B	Manual Bowl Guard	109092	Semi-Auto incl. Bowl Guard	109162	Semi-Auto incl.	109252	Metal Bowls	

# Product Range



## FILTER WATER SEPARATOR

- 30µm filter element
- Minimum pressure drop
- High percentage of water separation
- Optional 5µm filter elements – see page 13

PICTURE REF	FILTER WATER SEPARATOR	PORT SIZE			
		1/4"	3/8"	1/2"	1"
A	Recommended Flow at 6 bar (l/s)	9	14	31	83
	Max Operating Pressure (bar)	16	16	16	10
	Filter, Standard – white (µm)	30	30	30	30
	Filter, Option – yellow (µm)	5	5	5	5
	Condensate Capacity max (cl)	2.2	5.7	5.7	50
	Moisture Separation at recommended flow (%)	95	95	95	96

## OIL MIST LUBRICATOR

- Built in flow compensation to correct oil feed rate through fluctuations in air flow
- Large sight glass to monitor oil drip rate
- Filter element to ensure clean lubricant is passed into the air line
- Can be refilled without shutting off air supply

PICTURE REF	OIL MIST LUBRICATOR	PORT SIZE			
		1/4"	3/8"	1/2"	1"
B	Recommended Flow at 6 bar (l/s)	9	14	12	50
	Max Operating Pressure (bar)	16	16	16	10
	Oil Capacity max (cl)	0,5/8	4,5	12	12,50
	Oil/Air Ratio			Degressive (drops/min remains constant)	
	Oil Refill			Manual – also possible with pressure on	

## REGULATOR

- Secondary pressure relief to stabilise line pressure
- Adjustable control with locating jaws to prevent accidental rotation

PICTURE REF	REGULATOR	PORT SIZE			
		1/4"	3/8"	1/2"	1"
C	Recommended Flow at 6 bar (l/s)	9	14	32	83
	Input Pressure min/max (bar)	0/16	0/16	0/16	0/16
	Outlet Pressure min/max (bar)	0,5/8	0,5/8	0,5/8	0,5/10
	Pressure Differential min (bar)	0,2	0,2	0,2	0,2

# Product Range

**D**

**E**

## FILTER/REGULATORS

- Combined Filter-Water Separator and Pressure Regulator
- Secondary pressure relief
- 30µm filter element
- High percentage of moisture removal
- Ergonomic control knob with locking ring
- Optional 5µm filter elements – see page 13

PICTURE REF	FILTER/REGULATORS	PORT SIZE			
		1/4"	3/8"	1/2"	1"
D	Recommended Flow at 6 bar (l/s)	9	14	37	83
	Max Operating Pressure (bar)	16	16	16	10
	Filter, Standard – white (µm)	30	30	30	30
	Filter, Option – yellow (µm)	5	5	5	5
	Condensate Capacity max (cl)	2.2	5.7	5.7	50
	Moisture separation at recommended flow (%)	95	95	95	96
	Input pressure min/max (bar)	0/16	0/16	0/16	0/16
	Outlet pressure min/max (bar)	0,5/8	0,5/8	0,5/8	0,5/10
	Pressure Differential min (bar)	0,2	0,2	0,2	0,2

## SUBMICRO-FILTER UNITS

- Achieve 99.9999% filtration of particles at 0.01µm size
- Must be used together with standard filter (30 or 5µm element)
- Filter element from Ultrafilter
- Contamination Indicator standard (3/8" + 1/2" Port)
- All metal bowl standard on 1" Port size, optional metal bowl guard available (1/4", 3/8", 1/2" Ports)

PICTURE REF	SUBMICRO-FILTER UNITS	PORT SIZE		
		3/8"	1/2"	1"
E	Recommended Flow at 6 bar (l/s)	10	10	51
	Max Operating Pressure (bar)	10	10	10
	Condensate Capacity (cl)	4.8	4.8	15.5
	Pressure Drop at recommended flow (bar)	0.1	0.1	0.1

For Part Numbers – see Table below.

## ORDERING TABLE

PICTURE REF	DESCRIPTION	PORT SIZE			
		1/4" part no.	3/8" part no.	1/2" part no.	1" part no.
A	Filter, Semi-Auto Drain	–	109272	–	–
A	Filter, Semi-Auto Drain, Bowl Guard	–	–	109182	–
B	Oil Mist Lubricator	109072	109132	109202	–
C	Regulator	109062	109122	109192	–
D	Filter/Regulators, Semi-Auto Drain	–	109142	109232	–
D	Filter/Regulators, Semi-Auto Drain, Bowl Guard	–	–	109222	–
E	Submicro-Filter Units, manual drain	–	109172	109282	109302

# Accessories

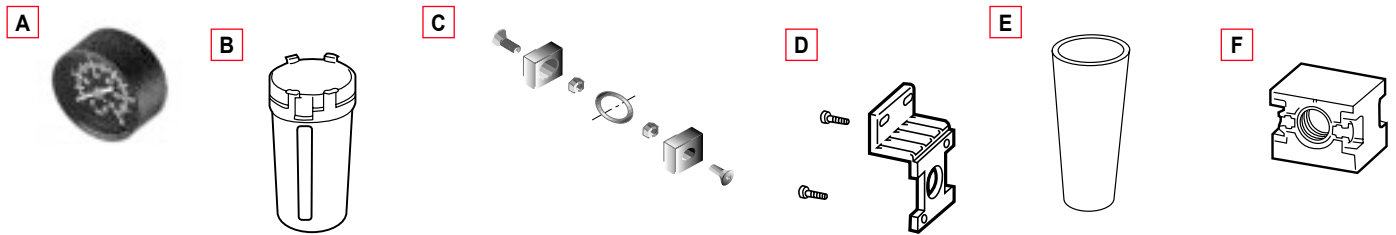

## PRESSURE GAUGE (included with Air Preparation Unit Sets only)

- 0-10 bar pressure

PICTURE REF	BSP SIZE	part no.
A	1/8" BSP male thread, 40mm Ø, 0-10 bar	109352
A	1/4" BSP male thread, 50mm Ø, 0-10 bar	109432
A	1/4" BSP male thread, 63mm Ø, 0-16 bar	109482

## BOWL GUARD KITS

- Fits around lubricator and filter bowls for added protection (Metal bowls are standard on 1" Port size units)

- Bowl guard with bayonet joint. The bowl guard fits all polycarbonate bowls irrespective of drainage and all lubricator bowls

PICTURE REF	PORT SIZE
B	3/8" + 1/2" part no. 109392

## ASSEMBLY/COUPLING KIT

- Coupling Kit for connecting 2 single units

- Enables air line service equipment to be quickly connected together to form an air preparation unit

PICTURE REF	PORT SIZE		
	1/4" part no.	3/8" + 1/2" part no.	1" part no.
C	-	109402	109472

## MOUNTING BRACKET KITS

- May be fitted to individual units for mounting to a vertical surface

- Included with all Filter/Regulator and Lubricator and Filter, Regulator, Lubricator Combination Sets

PICTURE REF	PORT SIZE		
	1/4" part no.	3/8" + 1/2" part no.	1" part no.
D	109322	109422	109462

## FILTER ELEMENTS

- A filter element of standard type is always delivered with the units
- The filter elements are made of polyethylene

- The standard 30µm filter element is designed for separation of particles larger than about 15µm and is white in colour
- The 5µm filter element is for separation of particles larger than about 5µm and is yellow in colour

PICTURE REF		PORT SIZE		
		1/4" part no.	3/8" + 1/2" part no.	1" part no.
E	30µm filter element	109342	109372	109452
E	5µm filter element	109332	109362	109442

## PORTING BLOCK KIT

- Provides an additional port supplying non-lubricated air

PICTURE REF	PORT SIZE
F	1/2" part no. 109382

# Dimensions and Spare Parts

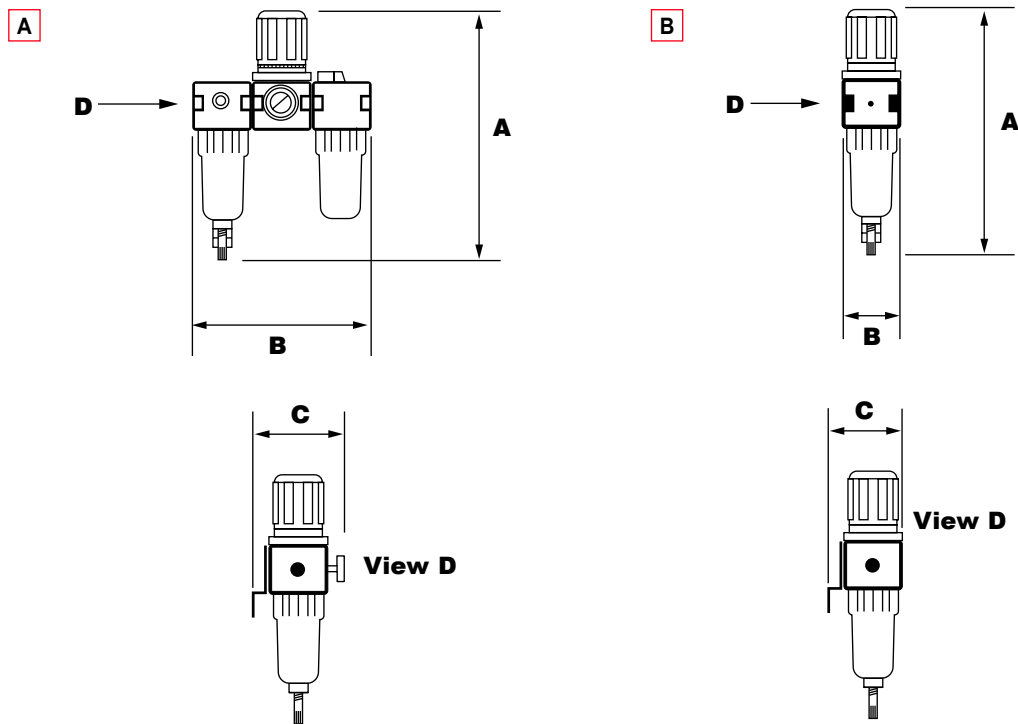

## AIR LINE SERVICE EQUIPMENT

PICTURE REF	PART NUMBER	DIMENSIONS			WEIGHT
		A	B	C	
		mm	mm	mm	kg
A	109082, 109092	185	95	112.5	0.75
A	109152, 109162, 109242, 109252	253	127	125	1.50
A	109262	253	189	125	1.85
A	109292	313	180	141	4.40
B	109062	92.5	50	77.5	0.30
B	109072	135.5	50	77.5	0.25
B	109102	139.5	50	77.5	0.25
B	109122, 109192	115	65	89	0.55
B	109132, 109202	177	65	89	0.55
B	109142, 109222, 109232	253	65	89	0.75
B	109172, 109182, 109272, 109282	185	65	89	0.55
B	109302	342.5	97	109.5	2.20

## SPARE PARTS FOR AIR LINE SERVICE EQUIPMENT

TO FIT MODEL PORT SIZE	DESCRIPTION	PART NUMBER
1/4" port	Lubricator Bowl	111582
	Filter Bowl	111592
	Filter Bowl – semi automatic drain	111602
	O ring for above	111622
	Lubricator Bowl	111632
3/8" & 1/2" port	Filter Bowl	111642
	Filter Bowl – semi automatic drain	111652
	O ring for above	111662

All bowls are polycarbonate

# Technical Data/Air Tool Oil

## SELECTING AIR SERVICE EQUIPMENT

The main criteria when selecting Desoutter Air Service equipment is the air consumption of the product to be coupled to it. The table below provides a guide to the maximum number of pneumatic tools of a certain air consumption that can be supplied via the 4 sizes of Air Service Equipment.

	PORT SIZE OF AIR SERVICE EQUIPMENT			
	1/4"	3/8"	1/2"	1"
Maximum Air Flow at 6 bar (l/s)	9	14	31	83
Air Consumption of Tools at 6 bar (l/s)				
0-4	2	3	6#	20#
5-8	1	1	3	9#
9-12	-	1	2	5#
13-15	-	-	2	4#
16-30	-	-	1	2
31-80	-	-	-	1

# For a lubricated system it is preferable to use 2 or more smaller size Air Service Units to ensure the correct amount of lubrication reaches all the tools or parts of the circuit.

## RECOMMENDED LUBRICATING OILS – GENERAL PNEUMATIC EQUIPMENT

Satisfactory operation of Desoutter Air Line Lubricators and effective lubrication depends upon the proper selection of lubricating oils. Most lubricating oils, preferably having good corrosion and oxidation resistant properties which conform with the following classifications, are suitable.

## PNEUMATIC TOOLS

For the lubrication of high speed pneumatic tools, high speed spindles and other light duty requirements, it is recommended that lubricating oils be used which have a kinematic viscosity below 50 cSt at 20°C. See table below.

OIL	GRADE OF OIL	VISCOSITY		SEAL COMPATIBILITY INDEX BS4832
		IP71 AT 40°C	CST AT 20°C	
Castrol	Hyspin AWS10	10	18.5	25
B.P.	HLP40	10	18.9	16
Shell	Tellus 15	10	19.5	15
Fina	Cirkan 15	10	21.0	17
Texaco	Spintex 60	10	22.8	34
Total	Azolla 10	-	23	16
Century	P198	15	28	26
Rocol	MO-4	15	29	20
Mobil	Gargoyle Artic Oil Light	15	31.5	17
Esso	Nuto H36	15	33	12.8
Valvoline	R125	22	46	7
Chevron	Spindle Oil 22	22	47.5	21
Gulf	Harmony 41	22	48.1	9
Fuchs	Silkair V622	22	48	-

## LUBRICATION OF PNEUMATIC TOOLS – OIL TYPES AVAILABLE

Although many Desoutter Power Tools have Dryline™ motors and are therefore able to be run without lubrication, service intervals may be extended by lubrication. Tools which do not have Dryline motors require lubrication. We recommend the use of Desoutter air line lubricators, which should be adjusted to give 5 drops/minute with the tool running at free running speed. See table below for available oil/quantities.

DESCRIPTION	USE WITH	PART NUMBER
Lubricating Oil 0.250 ltr – ISO VG15	All Desoutter power tools	27652
Lubricating Oil 1 ltr – ISO VG15		98532
Airoilene™ Oil 1 ltr – ISO VG22	All CP and Georges Renault power tools	P137145
5 ltr – ISO VG22		P089507
25 ltr – ISO VG22		P089508

## SPECIAL AIR TOOL TUNE-UP OIL: PROTECTO-LUBE

Air tools that are used infrequently or in hot/humid conditions can become low on power or may not start. This is due to old oil deposits/contaminants sticking inside the motor. To restore peak performance, we recommend use of Protecto-Lube tune-up oil from time to time.

DESCRIPTION	USE WITH	PART NUMBER
Protecto-Lube oil 0.5 ltr (1pt)	All air tools	CA000046
3.8 ltr (1 gal)		C138058

# Blow Gun

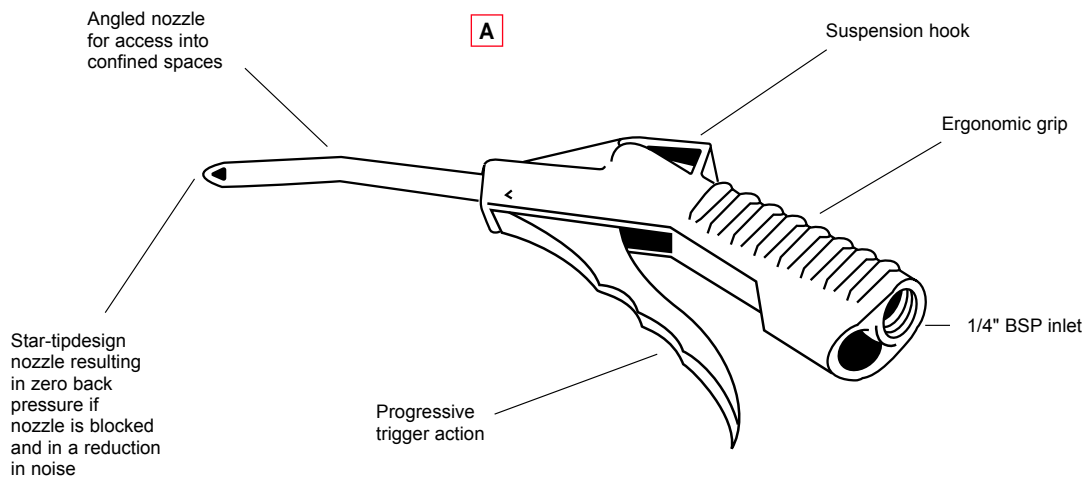

## BLOW GUN

PICTURE REF	SPECIFICATION		part no.
A	Maximum working pressure	12 bar	107202
	Air consumption	142 l/min	
	Noise level at 6 bar	79dB(A)	
	Weight	0.13kg	
	Operating temperature	-20+80°C	

## Safety Instructions

The goal of Desoutter is to produce tools that help the operator work safely and efficiently.

The most important safety device for this or any other tool is the operator. Care and good judgement are the best protection against injury.

All possible hazards cannot be covered here, but we have tried to highlight some of the important ones.

Individuals should look for and obey Caution, Warning and Danger signs placed on tools, and displayed in the workplace. Operators should read and follow safety instructions packed with each tool. For a copy of these instructions, contact your local Desoutter representative.

Learn how each tool works. Even if you have previously used similar tools, carefully check out each tool before you use it. Get the 'feel' of it and know its capabilities, limitations, potential hazards, how it operates and how it stops.

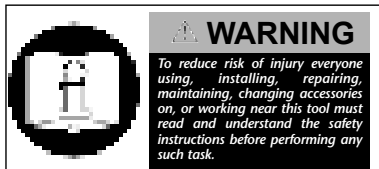

All tools are designed to operate at a line pressure of 6.3 bar +/- 0.15bar in accordance with ISO2787.

Tools are CE marked to comply with European Machinery Directive.

Specifications subject to change without prior notice.

Further occupational health and safety information can be obtained from the following web sites

<http://www.osha.gov> (USA)

<http://europe.osha.eu.int> (Europe).



### Compressed Air Hazards

- Air under pressure can cause injury. Never point an air hose at yourself or anyone else. Never blow your clothes free of dust with compressed air. Always direct exhaust air away from yourself and others in the work area.
- Always check for damaged or loose hoses and fittings before using an air tool, and replace if necessary. Whipping hoses can cause serious injury.
- Disconnect the tool from the air supply when not in use, before changing accessories, setting the torque, or when making repairs.
- Do not exceed rated air pressure to increase the output of the tool. This could cause injury and shorten tool life.
- Do not assemble quick coupler on the tool. Vibration can cause breakage resulting in a whipping air hose. Instead, use quick couplers on the end of a short leader hose.
- When universal twist couplings are used, lock pins must be installed to prevent accidental hose disconnection.
- Air tools are not intended for use in explosive atmospheres and are not insulated for contact with electric power sources.



### Projectile Hazards

- Always wear impact resistant eye and face protection when involved with or near the operation or repair of tools.



### Breathing Hazards

- Proper breathing protection must be worn when working with materials, which produce airborne particles.



### Noise Hazards

- Hearing loss can result from prolonged exposure to excessive sound levels.
- Use hearing protection as recommended by your employer or Occupational Health and Safety Regulations.



### Entanglement Hazards

- To reduce the risk of injury from entanglement, do not wear loose clothing when using rotating accessories.



### Additional Hazards

- Slip/Trip/Fall is a major cause of serious injury or death. Beware of excessive hose/cord left on the walking or work surface.



# Other Products

**Drills**



**Pneumatic Motors**



**Auto Feed Drills and Tappers**



**Impact Wrenches**



**Installation Accessories**



**Compression Riveting Tools**



**Fastening Tools**



**Grinders**



**Sanders**



**Measuring Units**



**Electric Nutrunners**

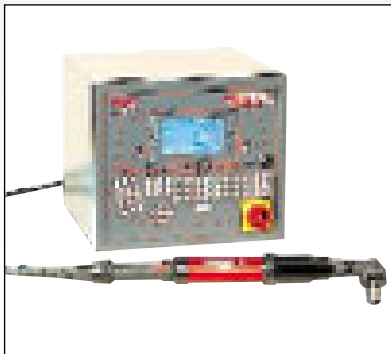

**Assembly Systems**

