

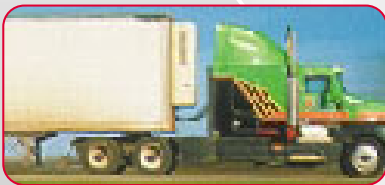

Drilling & Riveting Tools



Choosing the Right Drill

Choosing the right Drill



- **High power**
- **Durable – long life**
- **High precision**
- **Ergonomic**

Pistol Grip Drills

- Ideal for all general industrial drilling tasks
- Drilling capacity up to 1/2" Ø steel
- Best ergonomic shape – single and double handed use
- Use of side handle recommended for larger drills with high torque reaction

Straight Drills

- Mainly smaller diameter drilling less than 5/16" Ø steel
- Favored for vertical drilling
- Suitable for production line repetitive operation

Angle Drills

- Most commonly used in aerospace
- Ideal for restricted access application
- Drill capacity up to 5/16" Ø steel

Choosing the right Chuck

Key Adjustable Chuck

- Ideal for all general industrial drilling tasks
- High precision keyed chucks

Keyless Chucks

- Quick change (hand operated) chuck
- General purpose use

Collet Chuck

- Generally high speed drilling
- High precision
- Most commonly used in aerospace



Threaded Spindle

- Female threaded output
- Use with threaded shank drills
- Most commonly used in aerospace





Drill Selection Guide

PISTOL GRIP

TOOL TYPE	FREE SPEED	TITANIUM	STAINLESS STEEL	HARD CAST IRON, MEDIUM HARD STEEL	SOFT CAST IRON, MILD STEEL	HARD PLASTICS	ALUMINIUM, BRASS, COPPER, BRONZE	COMPOSITE	WOOD, SOFT PLASTICS, CHIPBOARD
	r/min		30-50ft/min	30-65ft/min	65-115ft/min	100-130ft/min	165-265ft/min	165-330ft/min	260-400ft/min
Drill Ø (in.)									
C22-P (Ø 1/4" - 6.5mm cap.) 	22600	-	-	-	-	-	5/64"	5/32"	5/64"
	12400	-	-	-	-	-	1/8"	-	1/8"
	6800	-	-	-	-	-	5/32"	3/16"	-
	4600	-	-	-	-	1/8"	1/4"	-	-
	3300	-	-	-	1/8"	3/16"	-	-	-
	2000	-	-	1/8"	1/4"	-	-	-	-
	1000	-	3/16"	1/4"	-	-	-	-	-
	500	1/8"	-	-	-	-	-	-	-
D22/23-P (Ø 5/16" - 8mm cap.) 	20000	-	-	-	-	-	-	5/32"	5/64"
	10500	-	-	-	-	-	5/64"	-	5/32"
	6000	-	-	-	-	-	5/32"	3/16"	1/4"
	4600	-	-	-	-	1/8"	1/4"	-	5/16"
	2900	-	-	-	5/32"	3/16"	5/16"	-	-
	1800	-	1/8"	5/32"	1/4"	5/16"	-	-	-
	1100	-	5/32"	1/4"	5/16"	-	-	-	-
	700	1/8"	9/32"	5/16"	-	-	-	-	-
400	1/4"	5/16"	-	-	-	-	-	-	
DR750 (Ø 5/16"-1/2" 8-13mm cap.) 	6000	-	-	-	-	-	5/32"	3/16"	1/4"
	4100	-	-	-	-	1/8"	1/4"	5/16"	3/8"
	3300	-	-	-	1/8"	5/32"	5/16"	3/8"	1/2"
	2700	-	-	1/8"	5/32"	3/16"	3/8"	1/2"	19/32"
	1300	-	5/32"	3/16"	11/32"	7/16"	3/4"	-	13/16"
	750	1/8"	9/32"	5/16"	19/32"	3/4"	13/16"	-	-

* above standard chuck capacity

STRAIGHT CASE

TOOL TYPE	FREE SPEED	TITANIUM	STAINLESS STEEL	HARD CAST IRON, MEDIUM HARD STEEL	SOFT CAST IRON, MILD STEEL	HARD PLASTICS	ALUMINIUM, BRASS, COPPER, BRONZE	COMPOSITE	WOOD, SOFT PLASTICS, CHIPBOARD
	r/min		30-50ft/min	30-65ft/min	65-115ft/min	100-130ft/min	165-265ft/min	165-330ft/min	260-400ft/min
Drill Ø (in.)									
C22-L (Ø 1/4" - 6.5mm cap.) 	22600	-	-	-	-	-	5/64"	5/32"	5/64"
	12400	-	-	-	-	-	1/8"	-	1/8"
	6800	-	-	-	-	-	5/32"	3/16"	-
	3300	-	-	-	1/8"	3/16"	-	-	-
	2000	-	-	1/8"	1/4"	-	-	-	-
	1000	-	3/16"	1/4"	-	-	-	-	-
	500	1/8"	-	-	-	-	-	-	-
D22/23-L (Ø 5/16" - 8mm cap.) 	20000	-	-	-	-	-	-	5/32"	5/64"
	10000	-	-	-	-	-	5/64"	-	5/32"
	5700	-	-	-	-	-	5/32"	3/16"	1/4"
	4400	-	-	-	-	1/8"	1/4"	-	5/16"
	2800	-	-	-	5/32"	3/16"	5/16"	-	-
	1750	-	1/8"	5/32"	1/4"	5/16"	-	-	-
	1050	1/8"	5/32"	1/4"	5/16"	-	-	-	-
	400	1/4"	5/16"	5/16"	-	-	-	-	-

Accessories

Model	A		B	
	in.	mm	in.	mm
C220-P-22600	7.16	182	0.66	22
C220-P-12400	7.80	198	0.66	22
C22-P-6800	7.60	193	1.18	30
C22-P-4600	8.23	209	1.18	30
C22-P-3300	7.60	193	1.18	30
C22-P-2000	8.23	209	1.18	30
C22-P-1000	8.23	209	1.18	30
C22-P-500	8.23	209	1.18	30

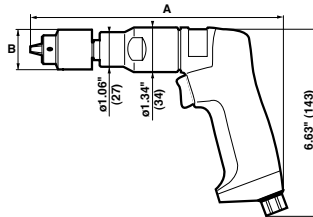

Model	A	
	in.	mm
D22-P-20000	6.65	169
D22-P-10500	8.27	210
D23-P-6000	6.89	175
D23-P-4600	6.89	175
D23-P-2900	7.89	175
D23-P-1800	7.76	197
D23-P-1100	7.76	197
D23-P-700	6.89	175
D23-P-400	6.89	175

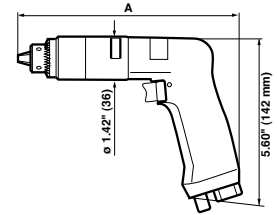

C220-P-.. / C22-P-.. / D22-P-.. / D23-P-..

ACCESSORIES INCLUDED

ITEM	PART NUMBER			
	C220	C22	D22	D23
1 Chuck threaded $\frac{5}{16}$ UNF capacity $\frac{5}{32}$ " - 4mm (with key)	103082			
• Chuck key	29932			
1 Chuck threaded $\frac{3}{8}$ UNF capacity $\frac{1}{4}$ " - 6.5mm (with key)		28942		
• Chuck key		29182		
1 Chuck threaded $\frac{3}{8}$ UNF capacity $\frac{5}{16}$ " - 8mm (without key)				410203
• Chuck key				410213
1 Chuck (Jacobs No. 1 taper) capacity $\frac{1}{4}$ " - 6.5mm (with key)			29492	
• Chuck key			29182	
2 Chuck Guard		252993	252993	

OPTIONAL ACCESSORIES

ITEM	PART NUMBER			
	C220	C22	D22	D23
3 Keyless Chuck threaded $\frac{3}{8}$ " UNF capacity $\frac{5}{16}$ " - 8mm		473433		473433
4 Chuck Guard	393793	393793		
5 Dust extraction kit	53242*	53242*	53242	53242
6 Side Handle	359623	359623	70442	70442
7 Offset Exhaust			77722	77722
8 Suspension Shackle (for horizontal tool suspension)	95842	95842	70082	70082
9 Chuck threaded $\frac{3}{8}$ UNF capacity $\frac{3}{8}$ " - 10mm				29042
• Chuck key				29232

* Note: C220 & C22 require chuck guard 393793 to be fitted

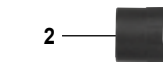

Pistol Grip Drills

0.3 - 0.38 Hp (0.2 - 0.28 kW) - 400 to 22600 r/min



A



B

Air inlet: 1/4" BSP/NPT. Vibration level: <math><2.5 \text{ m/s}^2</math>

PICTURE REF	MODEL	PART NUMBER	FREE SPEED		CHUCK SIZE		MOTOR POWER		STALL TORQUE		WEIGHT		AIR FLOW		MIN HOSE BORE		SOUND LEVEL
			r/min		in.	mm	Hp	kW	ln lb	Nm	lb	kg	cfm	l/s	in.	mm	
TRIGGER START – C SERIES																	
A	C220-P-22600	1443014	22600		5/32	4.0	0.30	0.20	2.7	0.3	1.52	0.69	16	7.8	1/4	6	75
A	C220-P-12400	1443024	12400		5/32	4.0	0.30	0.20	5.3	0.6	1.70	0.77	16	7.8	1/4	6	75
A	C22-P-6800	1443034	6800		1/4	6.5	0.30	0.20	9.7	1.1	1.67	0.76	16	7.8	1/4	6	75
A	C22-P-4600	1464844	4600		1/4	6.5	0.30	0.20	15.0	1.7	1.85	0.84	16	7.8	1/4	6	75
A	C22-P-3300	1443044	3300		1/4	6.5	0.30	0.20	19.5	2.2	1.67	0.76	16	7.8	1/4	6	75
A	C22-P-2000	1443064	2000		1/4	6.5	0.30	0.20	31.0	3.5	1.85	0.84	16	7.8	1/4	6	75
A	C22-P-1000	1443074	1000		1/4	6.5	0.30	0.20	62.8	7.1	1.85	0.84	16	7.8	1/4	6	75
A	C22-P-500	1443084	500		1/4	6.5	0.30	0.20	129.2	14.6	1.85	0.84	16	7.8	1/4	6	75
TRIGGER START – D SERIES																	
B	D22-P-20000	1289974	20000		1/4	6.5	0.38	0.28	8.9	1.0	1.76	0.80	18	8.5	3/8	10	78
B	D22-P-10500	1289894	10500		1/4	6.5	0.38	0.28	8.9	1.0	1.98	0.90	18	8.5	3/8	10	78
B	D23-P-6000	1364374	6000		5/16	8.0	0.38	0.28	17.7	2.0	1.98	0.90	18	8.5	3/8	10	78
B	D23-P-4600	1364454	4600		5/16	8.0	0.38	0.28	17.7	2.0	1.98	0.90	18	8.5	3/8	10	78
B	D23-P-2900	1364534	2900		5/16	8.0	0.38	0.28	26.6	3.0	1.98	0.90	18	8.5	3/8	10	78
B	D23-P-1800	1364794	1800		5/16	8.0	0.38	0.28	44.3	5.0	2.42	1.10	18	8.5	3/8	10	78
B	D23-P-1100	1364874	1100		5/16	8.0	0.38	0.28	79.7	9.0	2.42	1.10	18	8.5	3/8	10	78
B	D23-P-700	1364954	700		5/16	8.0	0.38	0.28	132.8	15.0	2.42	1.10	18	8.5	3/8	10	78
B	D23-P-400	1365004	400		5/16	8.0	0.38	0.28	212.0	24.0	2.42	1.10	18	8.5	3/8	10	78

Accessories

Chuck Designation	A	
	in.	mm
C13	2.40	61
C10	2.05	52
C8	1.69	43
K10	2.79	71
K8	2.36	60

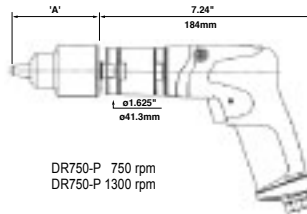

DR750-P 750 rpm
DR750-P 1300 rpm

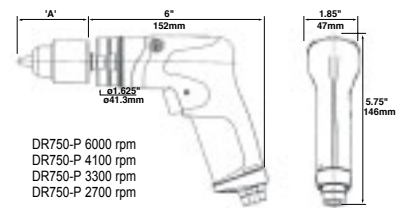

DR750-P 6000 rpm
DR750-P 4100 rpm
DR750-P 3300 rpm
DR750-P 2700 rpm

DR750-P...C. / DR750-P...K.

ACCESSORIES INCLUDED

ITEM	PART NUMBER				
	DR750...C8	DR750...C10	DR750...C13	DR750...K8	DR750...K10
1 Chuck threaded $\frac{3}{8}$ UNF capacity $\frac{5}{16}$ " - 8mm (without key)	410203				
• Chuck key	410213				
1 Chuck threaded $\frac{3}{8}$ UNF capacity $\frac{3}{8}$ " - 10mm (with key)		29042			
• Chuck key		29232			
1 Chuck threaded $\frac{3}{8}$ UNF capacity $\frac{1}{2}$ " - 13mm (with key)			473113		
• Chuck key			29242		
2 Keyless Chuck threaded $\frac{3}{8}$ UNF capacity $\frac{5}{16}$ " - 8mm				473433	
• Keyless Chuck threaded $\frac{3}{8}$ UNF capacity $\frac{3}{8}$ " - 10mm					473423
3 Chuck Guard	473143	473133			
4 Side Handle	473173	473173	473173	473173	473173
• Suspension Bail	473153	473153	473153	473153	473153

OPTIONAL ACCESSORIES

ITEM	PART NO.
5 Dust extraction kit	475033

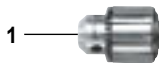

Pistol Grip Drills

High Power Drill

1 Hp (0.75 kW) - 750 to 6000 r/min



A



D



B



E



C



C

(Shown with side handle fitted)

Air Inlet: 1/4" BSP/NPT. Vibration level: <math><2.5\text{ m/s}^2</math>

PICTURE REF	MODEL	PART NUMBER	FREE SPEED	CHUCK SIZE		MOTOR POWER		STALL TORQUE		WEIGHT		AIR FLOW		MIN HOSE BORE		SOUND LEVEL
			r/min	in.	mm	Hp	kW	in lb	Nm	lb	kg	cfm	l/s	in.	mm	dB(A)
A	DR750-P6000-C8	1465124	6000	5/16	8	1.00	0.75	46	5.3	2.42	1.1	30	14	3/8	10	81
A	DR750-P4100-C8	1465114	4100	5/16	8	1.00	0.75	63	7.1	2.42	1.1	30	14	3/8	10	81
B	DR750-P3300-C10	1465104	3300	3/8	10	1.00	0.75	85	9.6	2.42	1.1	30	14	3/8	10	81
B	DR750-P2700-C10	1465094	2700	3/8	10	1.00	0.75	99	11.1	2.42	1.1	30	14	3/8	10	81
C	DR750-P1300-C10	1465084	1300	3/8	10	1.00	0.75	211	23.9	3.52	1.6	30	14	3/8	10	81
C	DR750-P750-C13	1465074	750	1/2	13	1.00	0.75	362	41.0	3.52	1.6	30	14	3/8	10	81

TRIGGER START - KEYLESS CHUCK MODELS

D	DR750-P6000-K8	1465164	6000	5/16	8	1.00	0.75	46	5.3	2.42	1.1	30	14	3/8	10	81
D	DR750-P4100-K8	1465154	4100	5/16	8	1.00	0.75	63	7.1	2.42	1.1	30	14	3/8	10	81
E	DR750-P3300-K10	1465144	3300	3/8	10	1.00	0.75	85	9.6	2.42	1.1	30	14	3/8	10	81
E	DR750-P2700-K10	1465134	2700	3/8	10	1.00	0.75	99	11.1	2.42	1.1	30	14	3/8	10	81

Accessories

Model	A	
	in.	mm
C220-L-22600	7.68	195
C220-L-12400	8.31	211
C22-L-6800	8.11	206
C22-L-3300	8.11	206
C22-L-2000	8.74	222
C22-L-1000	8.74	222
C22-L-500	8.74	222

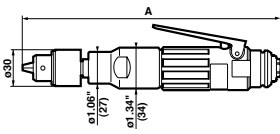

Model	A	
	in.	mm
D22-L/S-20000	8.34	212
D22-L/S-10000	9.96	253
D23-L-5700	8.58	218
D23-L-S-4400	8.58	218
D23-L-S-2800	8.58	218
D23-L-S-1750	9.45	240
D23-L-S-1050	9.45	240
D23-L-S-400	9.45	240

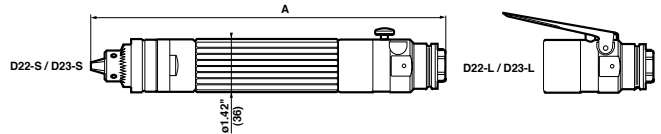

C220-L-.. / C22-L-.. / D22-L-.. / D23-L-.. / D22-S-.. / D23-S-..

ACCESSORIES INCLUDED

ITEM	PART NUMBER			
	C220	C22	D22	D23
1 Chuck threaded $\frac{5}{16}$ UNF capacity $\frac{5}{32}$ " - 4mm (with key)	103082			
• Chuck key	29932			
1 Chuck threaded $\frac{3}{8}$ UNF capacity $\frac{1}{4}$ " - 6.5mm (with key)		28942		
• Chuck key		29182		
1 Chuck threaded $\frac{3}{8}$ UNF capacity $\frac{5}{16}$ " - 8mm (without key)				410203
• Chuck key				410213
1 Chuck (Jacobs No. 1 taper) capacity $\frac{1}{4}$ " - 6.5mm (with key)				29492
• Chuck key				29182
2 Chuck Guard			252993	252993
• Clamp Ring – exhaust hose	235203	235203	235203	235203

OPTIONAL ACCESSORIES

ITEM	C220	C22	D22	D23
3 Keyless Chuck threaded $\frac{3}{8}$ " x 24 UNF capacity $\frac{3}{16}$ " - 8mm		473433		473433
4 Chuck Guard	393793	393793		
5 Dust extraction kit	53242*	53242*	53242	53242
6 Side Handle	359623	359623	70442	70442
7 Suspension Bail (for vertical tool suspension)	39433	39433	39433	39433
8 Suspension Shackle (for horizontal tool suspension)			70082	70082
9 Offset Exhaust			77722	77722
10 Chuck threaded $\frac{3}{8}$ UNF capacity $\frac{3}{8}$ " - 10mm				29042
• Chuck key				29232

* Note: C220 & C22 require chuck guard 393793 to be fitted

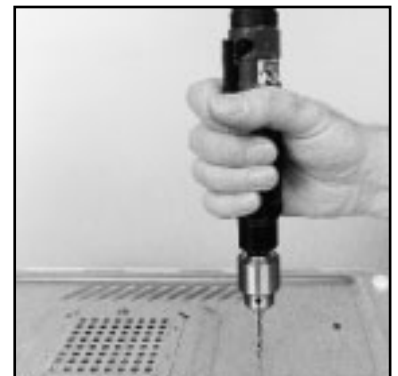
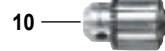
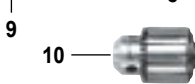

Straight Grip Drills

0.3 - 0.38 Hp (0.2 - 0.28 kW) - 400 to 22600 r/min

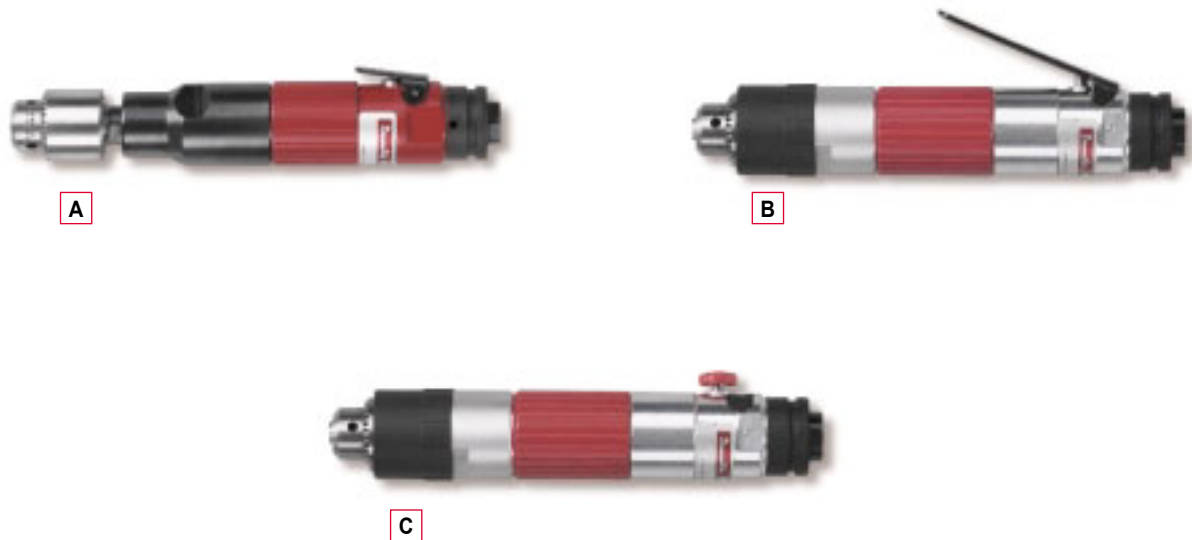

Air inlet: 1/4" BSP/NPT. Vibration level: <math><2.5 \text{ m/s}^2</math>.

PICTURE REF	MODEL	PART NUMBER	FREE SPEED	CHUCK SIZE		MOTOR POWER		STALL TORQUE		WEIGHT		AIR FLOW		MIN HOSE BORE		SOUND LEVEL
				r/min	in.	mm	Hp	kW	in lb	Nm	lb	kg	cfm	l/s	in.	
LEVER START – C SERIES																
A	C220-L-22600	1443094	22600	5/32	4.0	0.30	0.20	2.7	0.3	1.21	0.55	16	7.8	1/4	6	76
A	C220-L-12400	1443104	12400	5/32	4.0	0.30	0.20	5.3	0.6	1.39	0.63	16	7.8	1/4	6	76
A	C22-L-6800	1443114	6800	1/4	6.5	0.30	0.20	9.7	1.1	1.37	0.62	16	7.8	1/4	6	76
A	C22-L-3300	1443134	3300	1/4	6.5	0.30	0.20	19.5	2.2	1.37	0.62	16	7.8	1/4	6	76
A	C22-L-2000	1443144	2000	1/4	6.5	0.30	0.20	31.0	3.5	1.54	0.70	16	7.8	1/4	6	76
A	C22-L-1000	1443154	1000	1/4	6.5	0.30	0.20	62.8	7.1	1.54	0.70	16	7.8	1/4	6	76
A	C22-L-500	1443164	500	1/4	6.5	0.30	0.20	129.2	14.6	1.54	0.70	16	7.8	1/4	6	76
LEVER START – D SERIES																
B	D22-L-20000	1253134	20000	1/4	6.5	0.38	0.28	8.9	1.0	1.48	0.67	20	9.4	3/8	10	77
B	D22-L-10000	1253394	10000	1/4	6.5	0.38	0.28	8.9	1.0	1.65	0.75	20	9.4	3/8	10	77
B	D23-L-5700	1362914	5700	5/16	8.0	0.38	0.28	17.7	2.0	1.54	0.70	20	9.4	3/8	10	77
B	D23-L-4400	1363144	4400	5/16	8.0	0.38	0.28	17.7	2.0	1.54	0.70	20	9.4	3/8	10	77
B	D23-L-2800	1363304	2800	5/16	8.0	0.38	0.28	26.6	3.0	1.85	0.84	20	9.4	3/8	10	77
B	D23-L-1750	1363564	1750	5/16	8.0	0.38	0.28	53.1	6.0	1.85	0.84	20	9.4	3/8	10	77
B	D23-L-1050	1363724	1050	5/16	8.0	0.38	0.28	88.5	10.0	1.85	0.84	20	9.4	3/8	10	77
B	D23-L-400	1363984	400	5/16	8.0	0.38	0.28	221.3	25.0	1.85	0.84	20	9.4	3/8	10	77
BUTTON START – D SERIES																
C	D22-S-20000	1253054	20000	1/4	6.5	0.38	0.28	8.9	1.0	1.48	0.67	20	9.4	3/8	10	77
C	D22-S-10000	1253214	10000	1/4	6.5	0.38	0.28	8.9	1.0	1.65	0.75	20	9.4	3/8	10	77
C	D23-S-4400	1363064	4400	5/16	8.0	0.38	0.28	17.7	2.0	1.54	0.70	20	9.4	3/8	10	77
C	D23-S-2800	1363224	2800	5/16	8.0	0.38	0.28	26.6	3.0	1.54	0.70	20	9.4	3/8	10	77
C	D23-S-1750	1363484	1750	5/16	8.0	0.38	0.28	53.1	6.0	1.85	0.84	20	9.4	3/8	10	77
C	D23-S-1050	1363644	1050	5/16	8.0	0.38	0.28	88.5	10.0	1.85	0.84	20	9.4	3/8	10	77
C	D23-S-400	1363804	400	5/16	8.0	0.38	0.28	221.3	25.0	1.85	0.84	20	9.4	3/8	10	77

Angle Drill Selection



Considerations

- Size of hole to be drilled
- Cutting speed of material to be drilled
- Application – access to hole position
- Type of drill bit to be used
- Tool orientation
- Operator comfort/preference









There are also other considerations to be taken into account when selecting the right tool for the job.

Select the tool with the appropriate capacity and collet/chuck to suit the size of drill bit and hole to be drilled.

Where cycle time is critical it is advisable to use the higher power angle drills. This ensures that cutting speed is optimized during the drilling process.

Optimal cutting speed = Optimal cycle time = Productivity

DRILL SELECTION GUIDE – ANGLE DRILL

TOOL TYPE	FREE SPEED	TITANIUM	STAINLESS STEEL	HARD CAST IRON, MEDIUM HARD STEEL	SOFT CAST IRON, MILD STEEL	HARD PLASTICS	ALUMINIUM, BRASS, COPPER, BRONZE	COMPOSITE	WOOD, SOFT PLASTICS, CHIPBOARD
	r/min		30-50ft/min	30-65ft/min	65-115ft/min	100-130ft/min	165-265ft/min	165-330ft/min	260-400ft/min
		Drill Ø (in.)							
C32 (90° head) 	2900	–	–	–	1/8"	3/16"	3/16"	–	–
D32	5200	–	–	–	5/64"	3/16"	3/16"	5/32"	3/16"
	4000	–	–	–	5/64"	3/16"	3/16"	3/16"	–
	2800	–	–	–	1/8"	3/16"	3/16"	–	–
	1800	–	–	5/32"	3/16"	–	–	–	–
D33 (30° head) 	2000	–	–	5/32"	3/16"	–	–	–	–
D370 (360° head) 	3000	–	–	–	3/16"	3/16"	3/16"	3/16"	–
	2000	–	–	5/32"	3/16"	–	–	–	–
	3000	–	–	–	3/16"	3/16"	3/16"	3/16"	–
F32 (90° head) 	4500	–	–	–	–	1/8"	3/16"	3/16"	3/16"
	3100	–	–	–	1/8"	3/16"	3/16"	3/16"	–
	2200	–	1/8"	5/32"	3/16"	–	–	–	–
	1200	–	5/32"	3/16"	–	–	–	–	–
	830	5/64"	3/16"	–	–	–	–	–	–
	580	3/16"	–	–	–	–	–	–	–
D314 (90° head) 	4400	–	–	–	–	1/8"	1/4"	3/16"	1/4"
	2800	–	–	–	1/8"	3/16"	1/4"	1/4"	–
	1750	–	1/8"	5/32"	1/4"	1/4"	–	1/4"	–
	1050	–	5/32"	1/4"	1/4"	–	–	–	–
	400	1/4"	1/4"	1/4"	–	–	–	–	–
D315 (45° head) 	4400	–	–	–	–	1/8"	1/4"	3/16"	1/4"
	2800	–	–	–	1/8"	3/16"	1/4"	1/4"	–
	1750	–	1/4"	5/32"	1/4"	1/4"	–	1/4"	–
	1050	–	5/32"	1/4"	1/4"	–	–	–	–
D374 (360° head)	2800	–	–	–	1/8"	3/16"	1/4"	1/4"	1/4"
D3141 (90° head) 	2100	–	1/8"	1/8"	1/4"	5/16"	5/16"	5/16"	5/16"
D3143 (90° head)	770	–	9/32"	5/16"	5/16"	–	–	–	–
	2100	–	1/8"	1/8"	1/4"	1/4"	1/4"	1/4"	1/4"
	770	–	1/4"	1/4"	1/4"	–	–	–	–

Modular Angle Heads

Collet spindle 1/4" x 28 spindle

90° head
3/16" - 5mm capacity

0.16HP
120W

0.27HP
200W

0.38HP
280W

0.52HP
390W

Collet spindle & 1/4" x 28 spindle

30° head
3/16" - 5mm capacity

360° head
3/16" - 5mm capacity

0.16HP
120W

Collet spindle & 1/4" x 28 spindle

90° head
1/4" - 6.4mm capacity

360° head
1/4" - 6.4mm capacity

45° head
1/4" - 6.4mm capacity

0.38HP
280W

Collet Spindle Key chuck

90° head
8mm capacity

90° head
6.5mm capacity

0.38HP
280W

Accessories

Model	A	
	in.	mm
F32-L-4500C/S	10.55	268
F32-L-3100C/S	10.55	268
F32-L-2200C/S	10.55	268
F32-L-1200C/S	11.22	285
F32-L-830C/S	11.22	285
F32-L-580C/S	11.22	285

Model	A	
	in.	mm
D32-L-2800C/S	9.88	251
D32-LX-1800C/S	9.88	251
D32-S-5200	9.88	251
D32-S-4000	9.88	251
D32-S-2800	9.88	251

Model	A	
	in.	mm
C32-L-2900C/S	9.61	244

F32-L-.. / D32-L-.. / D32-LX-.. / D32-S-.. / C32-L-..

ACCESSORIES INCLUDED

ITEM	PART NO.
1 \emptyset 3/16" (4.8mm) capacity collet	2552
2 Compact lever	410303
3 Standard lever	305983
4 Exhaust hose	222458
• Clamp	235203

OPTIONAL ACCESSORIES

ITEM	PART NO.
5 Dust extractor kit	94972
6 Lock off lever	323893

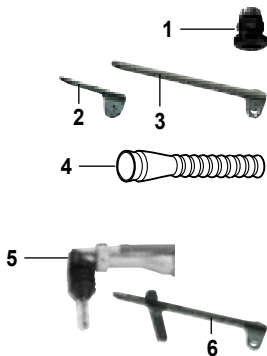

Collets		Collets	
Capacity	PART NO.	Capacity	PART NO.
• \emptyset 0.8mm	2152	• \emptyset 3.2mm (1/8")	2392
• \emptyset 0.9mm	2162	• \emptyset 3.3mm	2402
• \emptyset 1.0mm	2172	• \emptyset 3.4mm	2412
• \emptyset 1.1mm	2182	• \emptyset 3.5mm	2422
• \emptyset 1.2mm	2192	• \emptyset 3.6mm	2432
• \emptyset 1.3mm	2202	• \emptyset 3.7mm	2442
• \emptyset 1.4mm	2212	• \emptyset 3.8mm	2452
• \emptyset 1.5mm	2222	• \emptyset 3.9mm	2462
• \emptyset 1.6mm	2232	• \emptyset 4.0mm (5/32")	2472
• \emptyset 1.7mm	2242	• \emptyset 4.1mm	2482
• \emptyset 1.8mm	2252	• \emptyset 4.2mm	2492
• \emptyset 1.9mm	2262	• \emptyset 4.3mm	2502
• \emptyset 2.0mm	2272	• \emptyset 4.4mm	2512
• \emptyset 2.1mm	2282	• \emptyset 4.5mm	2522
• \emptyset 2.2mm	2292	• \emptyset 4.6mm	2532
• \emptyset 2.3mm	2302	• \emptyset 4.7mm	2542
• \emptyset 2.4mm (3/32")	2312	• \emptyset 4.8mm (3/16")	2552
• \emptyset 2.5mm	2322	• \emptyset 4.9mm	2562
• \emptyset 2.6mm	2332	• \emptyset 5.0mm	2572
• \emptyset 2.7mm	2342	• 1/16"	91442
• \emptyset 2.8mm	2352	• 3/32"	91452
• \emptyset 2.9mm	2362	• 1/8"	91462
• \emptyset 3.0mm	2372	• 5/32"	91472
• \emptyset 3.1mm	2382	• 3/16"	91482

Angle Drills

Compact 90° Angle Head

0.16 - 0.50 Hp (0.12 - 0.38 kW) - 580 to 5200 r/min



A



B



C



D

Vibration level: <math><2.5\text{ m/s}^2</math>

PICTURE REF	MODEL	PART NUMBER	FREE SPEED	MOTOR POWER		WEIGHT		AIR FLOW		AIR INLET	MIN HOSE BORE		SOUND LEVEL
			r/min	Hp	kW	lb	kg	cfm	l/s	BSP/NPT	in.	mm	dB(A)
COLLET SPINDLE – 3/16" (5mm) CAPACITY													
Lever Start													
A	F32-L-4500C	1462124	4500	0.50	0.38	2.2	1.00	24	11.5	1/4	3/8	10	76
A	F32-L-3100C	1462104	3100	0.50	0.38	2.2	1.00	24	11.5	1/4	3/8	10	76
A	F32-L-2200C	1462084	2200	0.50	0.38	2.2	1.00	24	11.5	1/4	3/8	10	76
A	F32-L-1200C	1462064	1200	0.50	0.38	2.5	1.15	24	11.5	1/4	3/8	10	76
A	F32-L-830C	1462044	835	0.50	0.38	2.5	1.15	24	11.5	1/4	3/8	10	76
A	F32-L-580C	1462024	580	0.50	0.38	2.5	1.15	24	11.5	1/4	3/8	10	76
B	D32-L-2800C	1460764	2800	0.38	0.28	1.6	0.72	19	9.4	1/4	3/8	10	77
B	D32-LX-1800C	1458224	1800	0.16	0.12	1.6	0.72	10	5.0	1/4	1/4	6	73
Button Start													
C	D32-S-5200	1465344	5200	0.38	0.28	1.6	0.72	20	9.4	1/4	3/8	10	77
C	D32-S-4000	1465354	4000	0.38	0.28	1.6	0.72	20	9.4	1/4	3/8	10	77
C	D32-S-2800	1465364	2800	0.38	0.28	1.6	0.72	20	9.4	1/4	3/8	10	77
Lever Start													
D	C32-L-2900C	1394434	2900	0.27	0.20	1.4	0.65	16	7.8	1/4	1/4	6	76
1/4" x 28 SPINDLE – 3/16" (5mm) CAPACITY													
Lever Start													
A	F32-L-4500S	1462114	4500	0.50	0.38	2.2	1.00	24	11.5	1/4	3/8	10	76
A	F32-L-3100S	1462094	3100	0.50	0.38	2.2	1.00	24	11.5	1/4	3/8	10	76
A	F32-L-2200S	1462074	2200	0.50	0.38	2.2	1.00	24	11.5	1/4	3/8	10	76
A	F32-L-1200S	1462054	1200	0.50	0.38	2.5	1.15	24	11.5	1/4	3/8	10	76
A	F32-L-830S	1462034	835	0.50	0.38	2.5	1.15	24	11.5	1/4	3/8	10	76
A	F32-L-580S	1462014	580	0.50	0.38	2.5	1.15	24	11.5	1/4	3/8	10	76
B	D32-L-2800S	1460754	2800	0.38	0.28	1.6	0.72	20	9.4	1/4	3/8	10	77
B	D32-LX-1800S	1458204	1800	0.16	0.12	1.6	0.72	10	5.0	1/4	1/4	6	73
D	C32-L-2900S	1394354	2900	0.27	0.20	1.4	0.65	16	7.8	1/4	1/4	6	76

Accessories

Model	A	
	in.	mm
D314-L-4400	9.61	244
D314-L-2800	9.61	244
D314-L-1750	10.47	266
D314-L-1050	10.47	266
D314-L-400	10.47	266

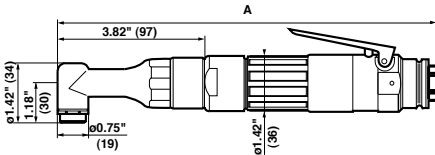

Model	A	
	in.	mm
D314-S/L-4400	9.61	244
D314-S/L-2800	9.61	244
D314-S/L-1750	10.47	266
D314-S/L-1050	10.47	266
D314-S/L-400	10.47	266

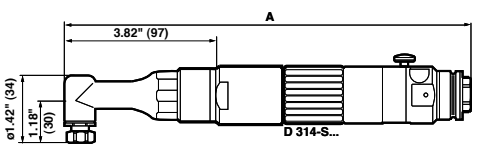

D314-S-.. / D314-L-..

ACCESSORIES INCLUDED

ITEM	PART NO.
1 \emptyset 1/4" (6.4mm) capacity collet	19182
2 Compact lever	410303
3 Exhaust hose	222458
• Clamp	235203

OPTIONAL ACCESSORIES

ITEM	PART NO.
4 Lock off lever	323893

Collets

Capacity	PART NO.
• \emptyset 1.6mm	18922
• \emptyset 1.8mm	18932
• \emptyset 2.0mm	18942
• \emptyset 2.2mm	18952
• \emptyset 2.4mm ($3/32$ ")	18962
• \emptyset 2.6mm	18972
• \emptyset 2.8mm	18982
• \emptyset 3.0mm	18992
• \emptyset 3.2mm ($1/8$ ")	19002
• \emptyset 3.4mm	19022
• \emptyset 3.6mm	19032
• \emptyset 3.8mm	19042
• \emptyset 4.0mm ($5/32$ ")	19052
• \emptyset 4.2mm	19062
• \emptyset 4.4mm	19072
• \emptyset 4.6mm	19082
• \emptyset 4.8mm ($3/16$ ")	19092
• \emptyset 5.0mm	19102
• \emptyset 5.2mm	19122
• \emptyset 5.4mm	19132
• \emptyset 5.6mm ($7/32$ ")	19142
• \emptyset 5.8mm	19152
• \emptyset 6.0mm	19162
• \emptyset 6.2mm	19172
• \emptyset 6.4mm ($1/4$ ")	19182

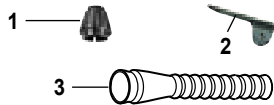

Angle Drills

Standard 90° Angle Head
0.38 Hp (0.28 kW) - 400 to 4400 r/min



Vibration level: <math><2.5\text{ m/s}^2</math>

PICTURE REF	MODEL	PART NUMBER	FREE SPEED	MOTOR POWER		WEIGHT		AIR FLOW		AIR INLET	MIN HOSE BORE		SOUND LEVEL
				r/min	Hp	kW	lb	kg	cfm		l/s	BSP/NPT	

COLLET SPINDLE – 1/4" (6.4mm) CAPACITY

Button Start

A	D314-S-4400	1380814	4400	0.38	0.28	1.7	0.77	20	9.4	1/4	1/4	6	77
A	D314-S-2800	1381204	2800	0.38	0.28	1.7	0.77	20	9.4	1/4	1/4	6	77
A	D314-S-1750	1381884	1750	0.38	0.28	2.0	0.90	20	9.4	1/4	1/4	6	77
A	D314-S-1050	1382274	1050	0.38	0.28	2.0	0.90	20	9.4	1/4	1/4	6	77

Lever Start

B	D314-L-4400	1380994	4400	0.38	0.28	1.7	0.77	20	9.4	1/4	1/4	6	77
B	D314-L-2800	1381384	2800	0.38	0.28	1.7	0.77	20	9.4	1/4	1/4	6	77
B	D314-L-1750	1381964	1750	0.38	0.28	2.0	0.90	20	9.4	1/4	1/4	6	77
B	D314-L-1050	1382354	1050	0.38	0.28	2.0	0.90	20	9.4	1/4	1/4	6	77
B	D314-L-400	1382774	400	0.38	0.28	2.0	0.90	20	9.4	1/4	1/4	6	77

1/4" x 28 SPINDLE – 1/4" (6.4mm) CAPACITY

Lever Start

B	D314-L-4400S	1456054	4400	0.38	0.28	1.7	0.77	20	9.4	1/4	1/4	6	77
B	D314-L-2800S	1456884	2800	0.38	0.28	1.7	0.77	20	9.4	1/4	1/4	6	77
B	D314-L-1750S	1456894	1750	0.38	0.28	2.0	0.90	20	9.4	1/4	1/4	6	77
B	D314-L-1050S	1456904	1050	0.38	0.28	2.0	0.90	20	9.4	1/4	1/4	6	77
B	D314-L-400S	1456914	400	0.38	0.28	2.0	0.90	20	9.4	1/4	1/4	6	77

Accessories

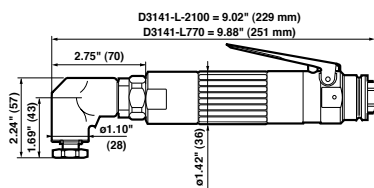

D 3141 S-2100 = 9.02" (229 mm)

D 3141 S-770 = 9.88" (251 mm)

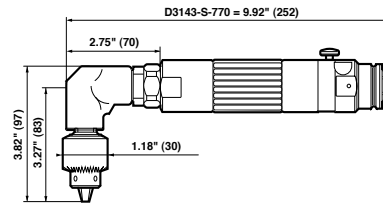
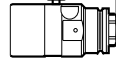

D 3143 L-2100

D 3143 L-2100 = 9.06" (230)

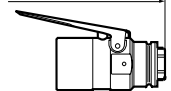

D3141-S-.. / D3141-L-.. / D3143-S-.. / D3143-L-..

ACCESSORIES INCLUDED

ITEM	PART NO.	
	D3141	D3143
1 \emptyset $5/16$ " (8mm) capacity collet	2872	
2 Chuck threaded $3/8$ " UNF capacity $1/4$ " (6.5mm)		28942
3 Exhaust hose	222458	222458
• Clamp	235203	235203

OPTIONAL ACCESSORIES

ITEM	D3141	D3143
4 Lock off lever	323893	323893

Collets

Capacity	D3141	Capacity	D3141
• \emptyset 2.4mm ($3/32$ ")	2592	• \emptyset 5.2mm	2732
• \emptyset 2.6mm	2602	• \emptyset 5.4mm	2742
• \emptyset 2.8mm	2612	• \emptyset 5.6mm ($7/32$ ")	2752
• \emptyset 3.0mm	2622	• \emptyset 5.8mm	2562
• \emptyset 3.2mm ($1/8$ ")	2632	• \emptyset 6.0mm	2772
• \emptyset 3.4mm	2642	• \emptyset 6.2mm	2782
• \emptyset 3.6mm	2652	• \emptyset 6.4mm ($1/4$ ")	2792
• \emptyset 3.8mm	2662	• \emptyset 6.6mm	2802
• \emptyset 4.0mm ($5/32$ ")	2672	• \emptyset 6.8mm	2812
• \emptyset 4.2mm	2682	• \emptyset 7.0mm	2822
• \emptyset 4.4mm	2692	• \emptyset 7.2mm ($9/32$ ")	2832
• \emptyset 4.6mm	2702	• \emptyset 7.4mm	2842
• \emptyset 4.8mm ($3/16$ ")	2712	• \emptyset 7.6mm	2852
• \emptyset 5.0mm	2722	• \emptyset 7.8mm	2862
		• \emptyset 8.0mm ($5/16$ ")	2872

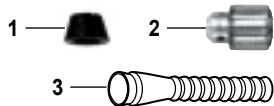

Angle Drills

Heavy Duty 90° Angle Head
0.38 Hp (0.28 kW) - 770 to 2100 r/min



Vibration level: <math><2.5 \text{ m/s}^2</math>

PICTURE REF	MODEL	PART NUMBER	FREE SPEED	MOTOR POWER		WEIGHT		AIR FLOW		AIR INLET	MIN HOSE BORE		SOUND LEVEL
			r/min	Hp	kW	lb	kg	cfm	l/s	BSP/NPT	in.	mm	dB(A)
COLLET SPINDLE – 5/16" (8mm) CAPACITY													
Button Start													
A	D3141-S-2100	1383084	2100	0.38	0.28	1.9	0.86	20	9.4	1/4	1/4	6	77
A	D3141-S-770	1383244	770	0.38	0.28	2.2	1.00	20	9.4	1/4	1/4	6	77
Lever Start													
B	D3141-L-2100	1383164	2100	0.38	0.28	1.9	0.86	20	9.4	1/4	1/4	6	77
B	D3141-L-770	1383324	770	0.38	0.28	2.2	1.00	20	9.4	1/4	1/4	6	77
KEY CHUCK – 1/4" (6.5mm) CAPACITY													
Button Start													
C	D3143-S-2100	1383404	2100	0.38	0.28	2.1	0.96	20	9.4	1/4	1/4	6	77
C	D3143-S-770	1383664	770	0.38	0.28	2.2	1.00	20	9.4	1/4	1/4	6	77
Lever Start													
D	D3143-L-2100	1383584	2100	0.38	0.28	2.1	0.96	20	9.4	1/4	1/4	6	77

Accessories

Model	A	
	in.	mm
D33-LX-2000	10.16	258
D33-L-3000	10.16	258

Model	A	
	in.	mm
D33-SX-2000	10.16	258
D33-S-5700	10.16	258
D33-S-4400	10.16	258
D33-S-2800	10.16	258

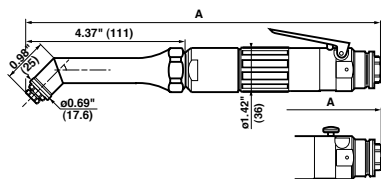

Model	A	
	in.	mm
D370-SX-2000	10.31	262

Model	A	
	in.	mm
D370-LX-2000	10.31	262
D370-L-3000	10.31	262

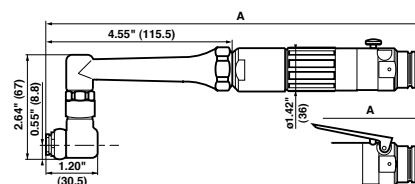

D33-SX-.. / D33-S-.. / D33-LX-.. / D33-L-.. / D370-SX-.. D370-LX-.. / D370-L-..

ACCESSORIES INCLUDED

ITEM	PART NO.
1 $\varnothing 3/16"$ (4.8mm) capacity collet	2552
2 Exhaust hose	222458
• Clamp	235203

OPTIONAL ACCESSORIES

ITEM	PART NO.
3 Lock off lever	323893
4 Compact lever	410303

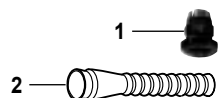

Collets

Capacity	D33-... D370-...	Capacity	D33-... D370-...
• $\varnothing 0.8\text{mm}$	2152	• $\varnothing 3.2\text{mm}$ (1/8")	2392
• $\varnothing 0.9\text{mm}$	2162	• $\varnothing 3.3\text{mm}$	2402
• $\varnothing 1.0\text{mm}$	2172	• $\varnothing 3.4\text{mm}$	2412
• $\varnothing 1.1\text{mm}$	2182	• $\varnothing 3.5\text{mm}$	2422
• $\varnothing 1.2\text{mm}$	2192	• $\varnothing 3.6\text{mm}$	2432
• $\varnothing 1.3\text{mm}$	2202	• $\varnothing 3.7\text{mm}$	2442
• $\varnothing 1.4\text{mm}$	2212	• $\varnothing 3.8\text{mm}$	2452
• $\varnothing 1.5\text{mm}$	2222	• $\varnothing 3.9\text{mm}$	2462
• $\varnothing 1.6\text{mm}$	2232	• $\varnothing 4.0\text{mm}$ (5/32")	2472
• $\varnothing 1.7\text{mm}$	2242	• $\varnothing 4.1\text{mm}$	2482
• $\varnothing 1.8\text{mm}$	2252	• $\varnothing 4.2\text{mm}$	2492
• $\varnothing 1.9\text{mm}$	2262	• $\varnothing 4.3\text{mm}$	2502
• $\varnothing 2.0\text{mm}$	2272	• $\varnothing 4.4\text{mm}$	2512
• $\varnothing 2.1\text{mm}$	2282	• $\varnothing 4.5\text{mm}$	2522
• $\varnothing 2.2\text{mm}$	2292	• $\varnothing 4.6\text{mm}$	2532
• $\varnothing 2.3\text{mm}$	2302	• $\varnothing 4.7\text{mm}$	2542
• $\varnothing 2.4\text{mm}$ (3/32")	2312	• $\varnothing 4.8\text{mm}$ (3/16")	2552
• $\varnothing 2.5\text{mm}$	2322	• $\varnothing 4.9\text{mm}$	2562
• $\varnothing 2.6\text{mm}$	2332	• $\varnothing 5.0\text{mm}$	2572
• $\varnothing 2.7\text{mm}$	2342	• 1/16"	91442
• $\varnothing 2.8\text{mm}$	2352	• 3/32"	91452
• $\varnothing 2.9\text{mm}$	2362	• 1/8"	91462
• $\varnothing 3.0\text{mm}$	2372	• 5/32"	91472
• $\varnothing 3.1\text{mm}$	2382	• 3/16"	91482



Angle Drills

Compact 30° and 90° x 90° Angle Head
0.16 - 0.38 Hp (0.12 - 0.28 kW) - 2000 to 5700 r/min

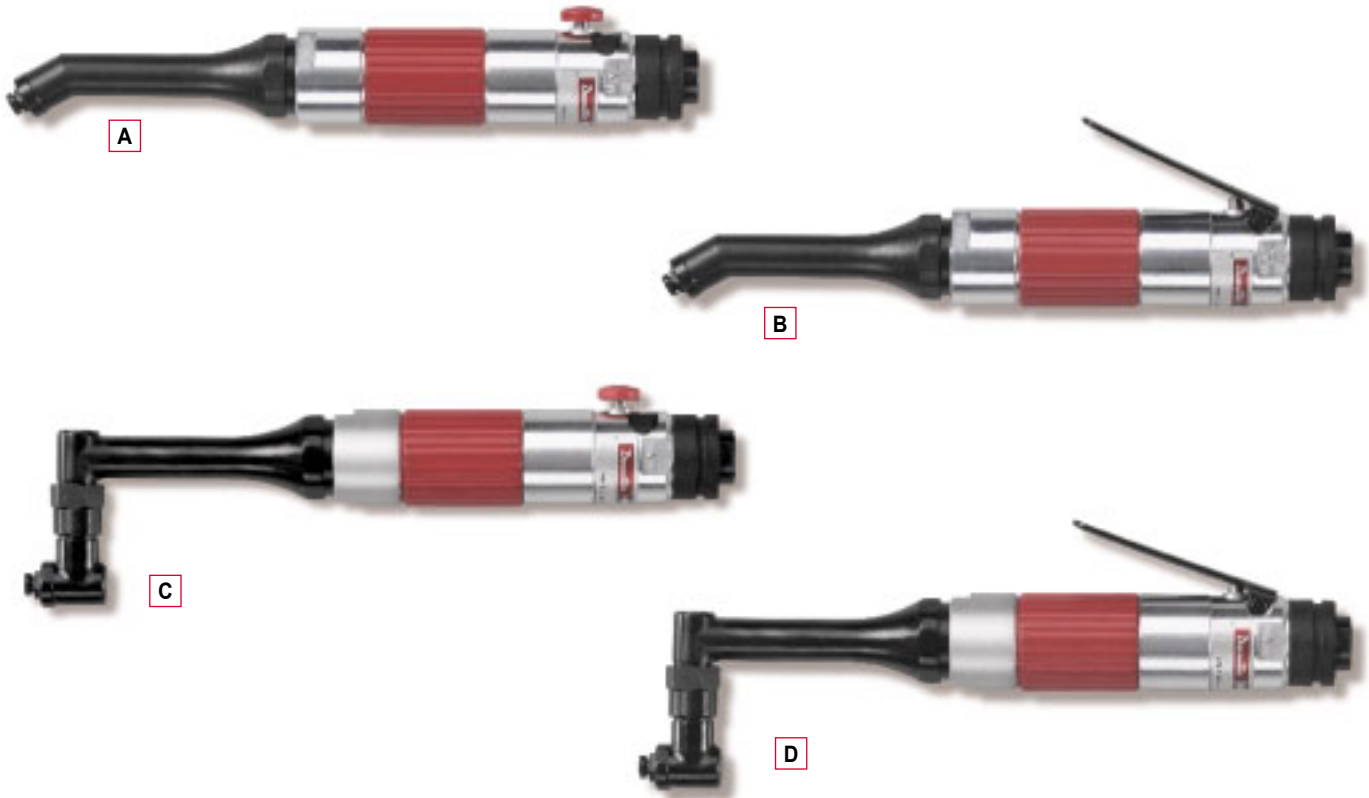

Vibration level: <math><2.5 \text{ m/s}^2</math>

PICTURE REF	MODEL	PART NUMBER	FREE SPEED	MOTOR POWER		WEIGHT		AIR FLOW		AIR INLET	MIN HOSE BORE		SOUND LEVEL
			r/min	Hp	kW	lb	kg	cfm	l/s	BSP/NPT	in.	mm	dB(A)

COLLET SPINDLE – 3/16" (5mm) CAPACITY

Button Start

A	D33-SX-2000	1379204	2000	0.16	0.12	1.4	0.62	10	5.0	1/4	1/4	6	73
A	D33-S-5700	1465374	5700	0.38	0.28	1.4	0.62	20	9.4	1/4	3/8	10	77
A	D33-S-4400	1465384	4400	0.38	0.28	1.4	0.62	20	9.4	1/4	3/8	10	77
A	D33-S-2800	1465394	2800	0.38	0.28	1.4	0.62	20	9.4	1/4	3/8	10	77

Lever Start

B	D33-LX-2000	1379384	2000	0.16	0.12	1.4	0.62	10	5.0	1/4	1/4	6	73
B	D33-L-3000	1464764	3000	0.38	0.28	1.4	0.62	20	9.4	1/4	3/8	10	77

1/4" x 28 SPINDLE – 3/16" (5mm) CAPACITY

Lever Start

B	D33-LX-2000S	1464834	2000	0.16	0.12	1.4	0.62	10	5.0	1/4	1/4	6	73
B	D33-L-3000S	1464824	3000	0.38	0.28	1.4	0.62	20	9.4	1/4	3/8	10	77

COLLET SPINDLE – 3/16" (5mm) CAPACITY

Button Start

C	D370-SX-2000	1379464	2000	0.16	0.12	1.6	0.72	10	5.0	1/4	1/4	6	73
D	D370-LX-2000	1379544	2000	0.16	0.12	1.6	0.72	10	5.0	1/4	1/4	6	73
D	D370-L-3000	1464794	3000	0.38	0.28	1.6	0.72	20	9.4	1/4	3/8	10	77

1/4" x 28 SPINDLE – 3/16" (5mm) CAPACITY

Lever Start

D	D370-LX-2000S	1464804	2000	0.16	0.12	1.6	0.72	10	5.0	1/4	1/4	6	73
D	D370-L-3000S	1464814	3000	0.38	0.28	1.6	0.72	20	9.4	1/4	3/8	10	77

Accessories

Model	A	
	in.	mm
D374-L/S-2800	10.31	262
D374-L-400	10.31	262

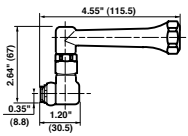

Model	A	
	in.	mm
D315-L-4400	10.59	269
D315-L-2800	10.59	269
D315-L-1750	11.46	291
D315-L-1050	11.46	291
D315-L-400	11.46	291

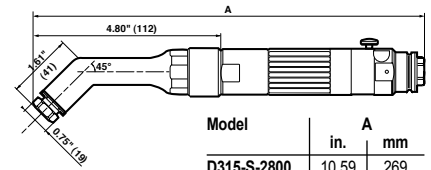
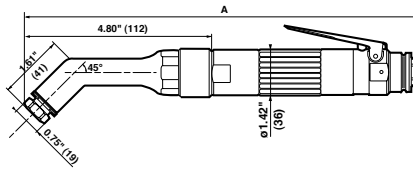

Model	A	
	in.	mm
D315-S-2800	10.59	269
D315-S-1750	11.46	291
D315-S-1050	11.46	291

D315-S-.. / D315-L-.. / D374-S-.. / D374-L-..

ACCESSORIES INCLUDED

ITEM	PART NO.
1 \varnothing 1/4" (6.4mm) capacity collet	19182
2 Exhaust hose	222458
• Clamp	235203

OPTIONAL ACCESSORIES

ITEM	PART NO.
3 Lock off lever	323893
4 Compact lever	410303

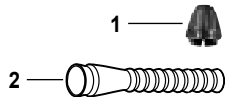

Collets

Capacity	PART NO.
• \varnothing 1.6mm	18922
• \varnothing 1.8mm	18932
• \varnothing 2.0mm	18942
• \varnothing 2.2mm	18952
• \varnothing 2.4mm ($3/32$ ")	18962
• \varnothing 2.6mm	18972
• \varnothing 2.8mm	18982
• \varnothing 3.0mm	18992
• \varnothing 3.2mm ($1/8$ ")	19002
• \varnothing 3.4mm	19022
• \varnothing 3.6mm	19032
• \varnothing 3.8mm	19042
• \varnothing 4.0mm ($5/32$ ")	19052
• \varnothing 4.2mm	19062
• \varnothing 4.4mm	19072
• \varnothing 4.6mm	19082
• \varnothing 4.8mm ($3/16$ ")	19092
• \varnothing 5.0mm	19102
• \varnothing 5.2mm	19122
• \varnothing 5.4mm	19132
• \varnothing 5.6mm ($7/32$ ")	19142
• \varnothing 5.8mm	19152
• \varnothing 6.0mm	19162
• \varnothing 6.2mm	19172
• \varnothing 6.4mm ($1/4$ ")	19182

Angle Drills

Standard 45° and 90° x 90° Angle Head
0.38 Hp (0.28 kW) - 400 to 4400 r/min

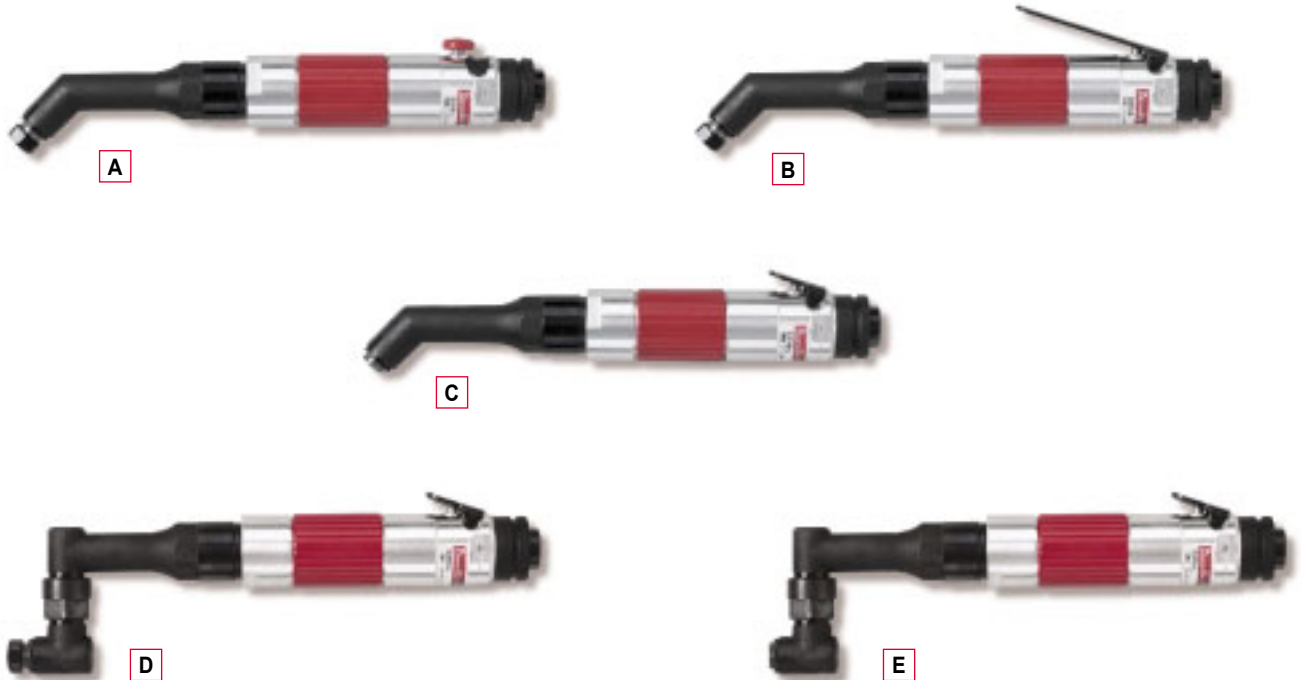

Vibration level: <math><2.5\text{ m/s}^2</math>

PICTURE REF	MODEL	PART NUMBER	FREE SPEED		MOTOR POWER		WEIGHT		LENGTH		AIR FLOW		AIR INLET	MIN HOSE BORE		SOUND LEVEL
			r/min	Hp	kW	lb	kg	in.	mm	cfm	l/s	BSP/NPT	in.	mm	dB(A)	
COLLET SPINDLE – 1/4" (6.4mm) CAPACITY																
Button Start																
A	D315-S-2800	1381464	2800	0.38	0.28	1.7	0.79	10.59	269	20	9.4	1/4	3/8	10	77	
A	D315-S-1750	1382014	1750	0.38	0.28	1.7	0.79	11.46	291	20	9.4	1/4	3/8	10	77	
A	D315-S-1050	1382434	1050	0.38	0.28	2.0	0.90	11.46	291	20	9.4	1/4	3/8	10	77	
Lever Start																
B	D315-L-4400	1462134	4400	0.38	0.28	1.7	0.79	10.59	269	20	9.4	1/4	3/8	10	77	
B	D315-L-2800	1381544	2800	0.38	0.28	1.7	0.79	10.59	269	20	9.4	1/4	3/8	10	77	
B	D315-L-1750	1382194	1750	0.38	0.28	2.0	0.90	11.46	291	20	9.4	1/4	3/8	10	77	
1/4" x 28 SPINDLE – 1/4" (6.4mm) CAPACITY																
Lever Start																
C	D315-L-4400S	1456934	4400	0.38	0.28	1.7	0.79	10.59	269	20	9.4	1/4	3/8	10	77	
C	D315-L-2800S	1456944	2800	0.38	0.28	1.7	0.79	10.59	269	20	9.4	1/4	3/8	10	77	
C	D315-L-1750S	1456954	1750	0.38	0.28	2.0	0.90	11.46	291	20	9.4	1/4	3/8	10	77	
C	D315-L-1050S	1456964	1050	0.38	0.28	2.0	0.90	11.46	291	20	9.4	1/4	3/8	10	77	
C	D315-L-400S	1456974	400	0.38	0.28	2.0	0.90	11.46	291	20	9.4	1/4	3/8	10	77	
COLLET SPINDLE – 1/4" (6.4mm) CAPACITY																
Button Start																
D	D374-S-2800	1381624	2800	0.38	0.28	1.9	0.88	10.31	262	20	9.4	1/4	1/4	6	77	
Lever Start																
D	D374-L-2800	1381704	2800	0.38	0.28	1.9	0.88	10.31	262	20	9.4	1/4	1/4	6	77	
D	D374-L-400	1465334	400	0.38	0.28	2.2	0.99	11.18	284	20	9.5	1/4	1/4	6	77	
1/4" x 28 SPINDLE – 1/4" (6.4mm) CAPACITY																
Lever Start																
E	D374-L-2800S	1456994	2800	0.38	0.28	1.9	0.88	10.31	262	20	9.4	1/4	1/4	6	77	

Accessories

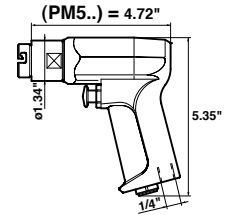
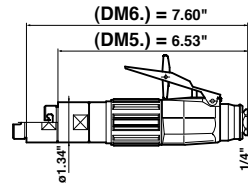

DM5.32 / DM6.9 / DM6.5 / PM5.32

ACCESSORIES INCLUDED

	ANGLE HEAD	DRILLS
• 1/4" air hose nipple for 6mm ID hose	615 396 003 0	615 399 494 0
• Wrench 10mm	615 396 237 0	615 399 495 0
• Wrench 14mm	615 801 005 0	615 399 496 0
• Wrench 8-9.5mm (Qty 2)		615 801 030 0

OPTIONAL ACCESSORIES

ITEM		PART NO.
1	Complete Silencer kit PM5	615 399 253 0
2	Complete Silencer kit DM5/DM6	615 399 423 0
3	Exhaust hose	615 875 106 0

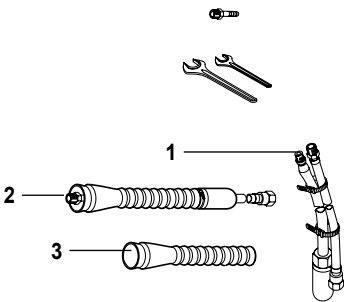

Capacity	ANGLE HEAD		Capacity	ANGLE HEAD	
	A	B		A	B
• ø 1.0mm	615 396 003 0	615 399 494 0	• ø 3.4mm	615 396 003 0	615 399 494 0
• ø 1.1mm	615 396 237 0	615 399 495 0	• ø 3.5mm	615 396 237 0	615 399 495 0
• ø 1.2mm		615 399 496 0	• ø 3.6mm		615 399 496 0
• ø 1.3mm			• ø 3.7mm		
• ø 1.4mm		2172	• ø 3.8mm		2412
• ø 1.5mm		2182	• ø 3.9mm		2422
• ø 1.7mm		2192	• ø 4.0mm (5/32")	615 526 071 0	2432
• ø 1.8mm		2202	• ø 4.1mm		2442
• ø 1.9mm		2212	• ø 4.2mm		2452
• ø 2.0mm	615 526 066 0	2222	• ø 4.3mm		2462
• ø 2.1mm		2242	• ø 4.4mm		2472
• ø 2.2mm		2252	• ø 4.5mm	615 526 073 0	2482
• ø 2.3mm		2262	• ø 4.6mm		2492
• ø 2.4mm (3/32")		2272	• ø 4.7mm		2502
• ø 2.5mm	615 526 068 0	2282	• ø 4.8mm (9/16")		2512
• ø 2.6mm		2292	• ø 4.9mm		2522
• ø 2.7mm		2302	• ø 5.0mm	615 526 075 0	2532
• ø 2.8mm		2312	• ø 5.5mm	615 526 077 0	2542
• ø 2.9mm		2322	• ø 6.0mm	615 526 079 0	2552
• ø 3.0mm	615 526 069 0	2332	• ø 6.5mm (1/4")	615 526 081 0	2562
• ø 3.1mm		2342	• ø 7.0mm	615 526 083 0	2572
• ø 3.2mm (1/8")		2352	• ø 7.5mm	615 526 084 0	
• ø 3.3mm		2362	• ø 8.0mm (5/16")	615 526 088 0	



CHUCK MOUNTING	
• Chuck with key capacity 1/4" (0 to 6mm)	28942
• Keyless Chuck capacity 5/16" (0 to 8mm)	473433

Multi Drills

0.4 Hp (0.3 kW) - 490 to 3200 r/min

Supplied without collet and chuck

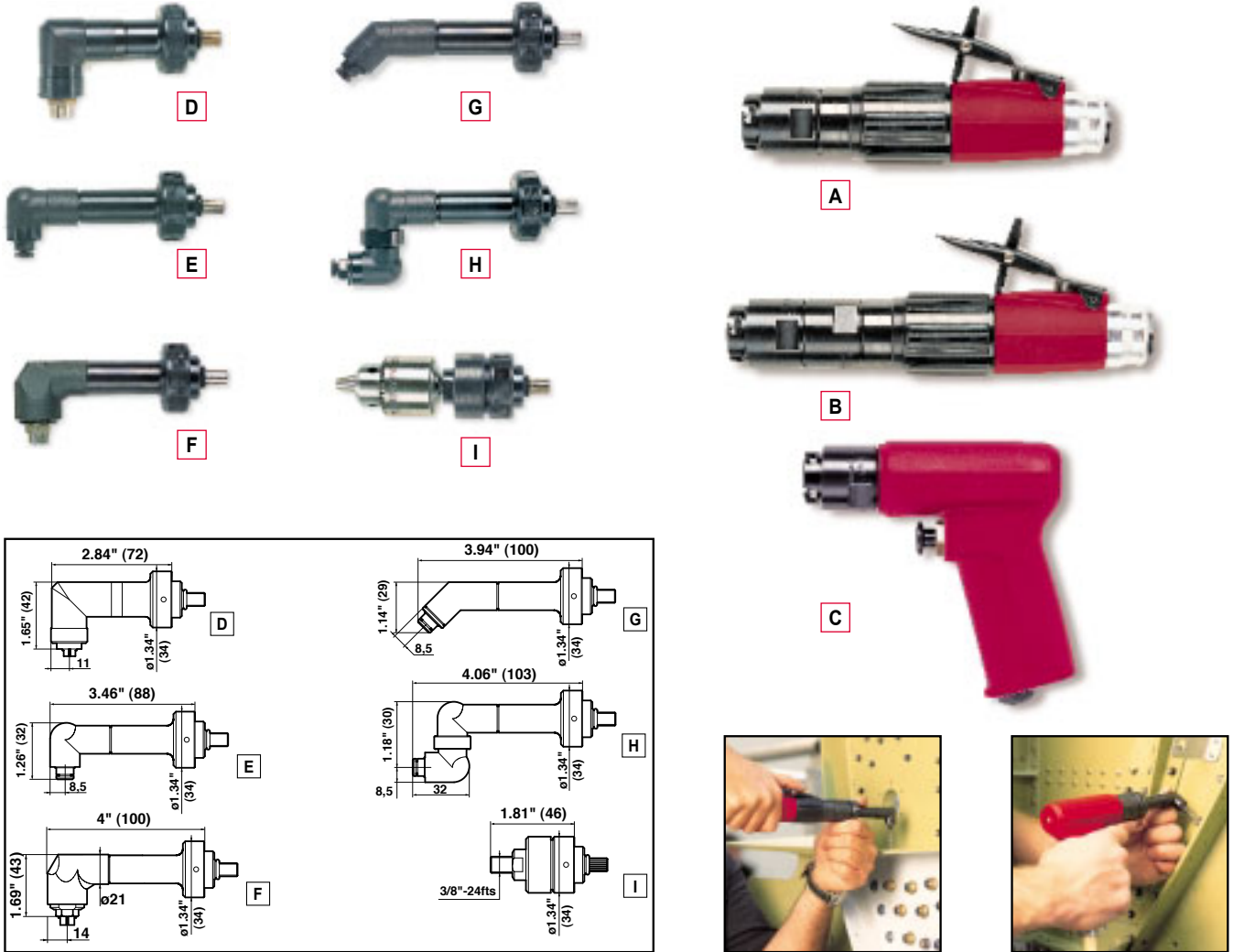

PICTURE REF	MODEL	PART NUMBER	FREE SPEED	MOTOR POWER	WEIGHT		AIR FLOW		AIR INLET	HOSE ID	SOUND LEVEL	
			r/min	Hp	kW	lb	kg	cfm				l/s
MULTI DRILLS												
A	DM5.32	615 176 023 0	3200	0.4	0.3	1.5	0.69	17	8	1/4	1/4	72
B	DM6.9	615 176 025 0	800	0.4	0.3	1.8	0.82	17	8	1/4	1/4	72
B	DM6.5	615 176 024 0	490	0.4	0.3	1.8	0.82	17	8	1/4	1/4	72
C	PM5.32	615 176 034 0	3200	0.4	0.3	1.6	0.72	17	8	1/4	1/4	72

PICTURE REF	PART NUMBER	DESIGNATION	COLLET MAX. CAPACITY	WEIGHT		RECOMMENDED FREE SPEED
			in.	lb	kg	r/min
D	615 396 003 0	90° Angle Head	5/16	0.55	0.25	800/490
E	615 399 494 0	90° Angle Head	3/16	0.45	0.20	3200
F	615 396 237 0	90° Angle Head	5/16	0.65	0.30	3200
G	615 399 495 0	45° Angle Head	3/16	0.45	0.20	3200
H	615 399 496 0	360° Angle Head	3/16	0.55	0.25	3200
I	615 396 145 0	Chuck mounting 3/8" x 24 tpi		0.45	0.20	3200

Accessories

Model	in.	A	mm
D16-L-1000	11.77		299
D16-L-500	12.20		310

Model	in.	A	mm
D16-S-1000	11.77		299
D16-S-500	12.20		310

Model	in.	A	mm
D16-P-750	11.69		297
D16-P-450	12.12		308

Model	in.	A	mm
2F16-L-700	10.98		279
2F16-L-250	11.73		298

D16-S-.. / D16-L-.. / D16-P-.. / 2F16-L-..

ACCESSORIES INCLUDED

ITEM	PART NUMBER		
	D16-S-1000 D16-L-1000 D16-P-750	D16-S-500 D16-L-500 D16-P-450	2F16-L-700 2F16-L-250
1 Chuck with key capacity 1/4" (6.5mm)	29492		
• Key	29182		
1 Chuck with key capacity 3/8" (10mm)		29042	
• Key		29232	
2 Precision collet tap holder			29462
3 Collet capacity 9/64"- 1/4" (3.5-6.5mm)			29482
4 Exhaust hose (except D16-P-..)	222453	222453	222453
• Clamp	235203	235203	235203

OPTIONAL ACCESSORIES

ITEM	PART NO.
5 Lock off lever	323893
6 Precision collet tap holder	29452
7 Collet capacity 3/16"- 5/16" (4.5-8mm)	29472
8 *Tap Holder	69922
9 Quick Release Chuck	16852
10 *Quick Release Tap Holder	69872

*Collets for Tap Holders:

TAP SIZE		BA	SHANK DIA		PART NO.
mm	in.		mm	mm	
• M2.2 & M2.5		6 & 8	2.8		2612
• M3	1/8"	5	3.2		2632
• M3.5		4	3.6		2652
• M4			4.0		2672
• M4.5		3	4.5		2702
• M5	3/16"	2	5.0		2722
• M5.5	7/32"	1	5.6		2752
• M6	1/4"	0	6.3		2792
• M7	9/32"		7.1		2832
• M8 & M11	5/16" & 7/16"		8.0		2872
• M9 & M12	1/2"		9.0		69882
• M10	3/8"		10.0		69892
• *Wrench for Tap Holder collet nut					29443
• *2mm A/F hexagon key for Tap Holder set screws					206773

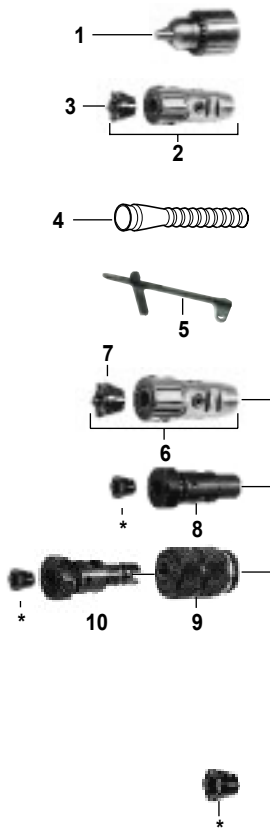

Tappers



A



B



C



D

Air inlet: 1/4" BSP/NPT. Vibration level: <math><2.5\text{ m/s}^2</math>

PICTURE REF	MODEL	PART NUMBER	FREE SPEED	REVERSE SPEED	CHUCK SIZE		MAX. TAPPING TORQUE		WEIGHT		AIR FLOW		MIN HOSE BORE		SOUND LEVEL
			r/min	r/min	in.	mm	in lb	Nm	lb	kg	cfm	l/s	in.	mm	dB(A)

D SERIES

Button Start – push/pull reverse

A	D16-S-1000	1274544	1000	2000	1/4	6.5	38	4.3	2.86	1.3	20	9.4	3/8	10	77
A	D16-S-500	1274384	500	1000	3/8	10.0	76	8.6	3.08	1.4	20	9.4	3/8	10	77

Lever Start – push/pull reverse

B	D16-L-1000	1274624	1000	2000	1/4	6.5	38	4.3	2.86	1.3	20	9.4	3/8	10	77
B	D16-L-500	1274464	500	1000	3/8	10.0	76	8.6	3.08	1.4	20	9.4	3/8	10	77

Trigger Start – push/pull reverse

C	D16-P-750	1288084	750	1500	1/4	6.5	55	6.2	3.75	1.7	18	8.5	3/8	10	78
C	D16-P-450	1287934	450	900	3/8	10.0	98	11.1	3.97	1.8	18	8.5	3/8	10	78

F SERIES

Lever Start – button reverse – stand mounted

D	2F16-L-700	1241394	700	700	1/4	6.5	59	6.7	3.75	1.7	23	11.1	3/8	10	76
D	2F16-L-250	1241474	250	250	1/4	6.5	155	17.5	3.97	1.8	23	11.1	3/8	10	76

Accessories

Angle Head	A		B		Part No.
	in.	mm	in.	mm	
Standard reach	1.10	28	2.32	59	108302
Extended reach	1.97	50	3.07	78	108312

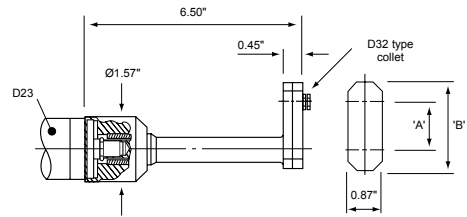

OFFSET ANGLE HEAD

ACCESSORIES

ITEM	PART NO.
A Offset Angle Head – Standard reach	108302
B Offset Angle Head – Extended reach	108312
• Service kits (standard reach) – gears and bearings set	461273
• Service kits (extended reach) – gears and bearings set	461283

Offset Angle Head components

ITEM	
1	Mounting block
2	Drive spindle
3	Offset Angle Head body

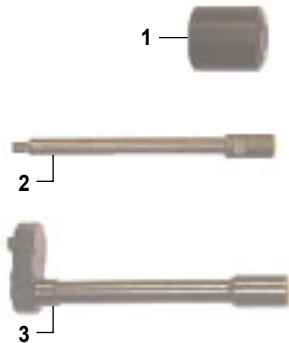

To fit the offset angle head to a D23 drill the chuck guard and chuck should be removed; the drive spindle is then fitted followed by the mounting block. The offset angle head body is then engaged with the drive shaft and secured to the mounting block by means of set screws.

The head may be rotated through 360° to the desired orientation prior to securing to the mounting block.

The drill bit is held by means of a standard collet (D32 type).

Speciality Tools

Offset Angle Head

Introduction

Offset Angle Heads are used to provide solutions to drill holes in areas where access is very limited.

Two types of offset angle head module (standard and extended reach) suitable for mounting to the D23 (straight and pistol versions) drill are available.

To order please ensure that you list both the D23 Drill plus the Offset Angle Head to suit your requirements.

e.g.: D23-P-700 + Standard reach Part No. 108302



Vibration level: <math><2.5 \text{ m/s}^2</math>

PICTURE REF	MODEL	PART NUMBER	FREE SPEED	CHUCK SIZE		MOTOR POWER	STALL TORQUE	WEIGHT		LENGTH	AIR FLOW	AIR INLET	MIN HOSE BORE		SOUND LEVEL
			r/min	in.	mm	kW	Nm	lb	kg	mm	cfm	BSP/NPT	in.	mm	dB(A)
PISTOL GRIP DRILLS – TRIGGER START – D SERIES															
•	D23-P-6000	1364374	6000	0.315	8.0	0.28	2.0	1.98	0.90	175	18	1/4	3/8	10	78
•	D23-P-4600	1364454	4600	0.315	8.0	0.28	2.0	1.98	0.90	175	18	1/4	3/8	10	78
•	D23-P-2900	1364534	2900	0.315	8.0	0.28	3.0	1.98	0.90	175	18	1/4	3/8	10	78
•	D23-P-1800	1364794	1800	0.315	8.0	0.28	5.0	2.42	1.10	197	18	1/4	3/8	10	78
•	D23-P-1100	1364874	1100	0.315	8.0	0.28	9.0	2.42	1.10	197	18	1/4	3/8	10	78
•	D23-P-700	1364954	700	0.315	8.0	0.28	15.0	2.42	1.10	197	18	1/4	3/8	10	78
•	D23-P-400	1365004	400	0.315	8.0	0.28	24.0	2.42	1.10	197	18	1/4	3/8	10	78
STRAIGHT GRIP DRILLS – LEVER START – D SERIES															
•	D23-L-5700	1362914	5700	0.315	8.0	0.28	2.0	1.54	0.70	218	20	1/4	3/8	10	77
•	D23-L-4400	1363144	4400	0.315	8.0	0.28	2.0	1.54	0.70	218	20	1/4	3/8	10	77
•	D23-L-2800	1363304	2800	0.315	8.0	0.28	3.0	1.85	0.84	218	20	1/4	3/8	10	77
•	D23-L-1750	1363564	1750	0.315	8.0	0.28	6.0	1.85	0.84	240	20	1/4	3/8	10	77
•	D23-L-1050	1363724	1050	0.315	8.0	0.28	10.0	1.85	0.84	240	20	1/4	3/8	10	77
•	D23-L-400	1363984	400	0.315	8.0	0.28	25.0	1.85	0.84	240	20	1/4	3/8	10	77
STRAIGHT GRIP DRILLS – BUTTON START – D SERIES															
•	D23-S-4400	1363064	4400	0.315	8.0	0.28	2.0	1.54	0.70	218	20	1/4	3/8	10	77
•	D23-S-2800	1363224	2800	0.315	8.0	0.28	3.0	1.54	0.70	218	20	1/4	3/8	10	77
•	D23-S-1750	1363484	1750	0.315	8.0	0.28	6.0	1.85	0.84	240	20	1/4	3/8	10	77
•	D23-S-1050	1363644	1050	0.315	8.0	0.28	10.0	1.85	0.84	240	20	1/4	3/8	10	77
•	D23-S-400	1363804	400	0.315	8.0	0.28	25.0	1.85	0.84	240	20	1/4	3/8	10	77

Accessories

A27-A-.. / C27-AX-.. / D156-S-.. / D156-P-..

ACCESSORIES INCLUDED

ITEM	PART NO.			
	A27-A	C27-AX	D156-S	D156-P
• Collet – 3mm capacity	2372			
• Collet – 4mm capacity	2472			
• Collet – 1/4" (6.4mm) capacity		8482		
1 Cutter (90° point) – 5mm dia	91752			
1 Cutter (90° point) – 10mm dia		91572		
2 Cutter Guard			18822	18822
• Air Hose (M5 x 1/8" BSP) – 4mm bore	79322			
• Adaptor (1/8" BSP female to 1/8" NPT male)	271463			
• Suspension Bail	280903	39433		
• Exhaust hose	280913	222453	222453	
• Exhaust Hose Clip		235203	235203	
• Collet Nut Wrench	82623	18582		
• Collet Spindle Wrench	268263	159003	15533	15533
• Cutter Guard Wrench			38873	38873

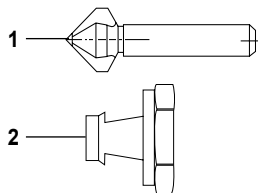

OPTIONAL ACCESSORIES

ITEM	PART NO.		
	C27-AX	D156-S	D156-P
3 Countersink depth stop	322053		
• Suspension Bail		39433	
• Offset exhaust silencer		77722	



D156 Cutter Detail

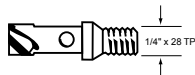

Hole Deburring & Rivet Shaving



A



B

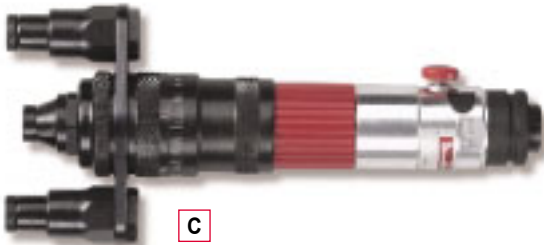

C



D

C27 Vibration level: 4.3 m/s^2. Others Vibration level: 2.5 m/s^2. D156 spindle 1/4"-28 female thread

PICTURE REF	MODEL	PART NUMBER	FREE SPEED	COLLET SIZE	MAXIMUM CUTTER DIA.		WEIGHT		LENGTH		AIR FLOW		AIR INLET	MIN. HOSE BORE		SOUND LEVEL
			r/min	mm	in.	mm	lb	kg	in.	mm	cfm	l/s	BSP/NPT	in.	mm	dB(A)

HOLE DEBURRING TOOLS – PUSH TO START

(integral speed regulator)

A	A27-A-1300	1406594	100 - 1300	4	–	–	0.52	0.24	6.77	172	5	2.4	M5	1/8	3	64
B	C27-AX-1450	1405414	100 - 1450	6	–	–	1.05	0.48	8.58	218	13	6.2	1/4"	1/4	6	73

RIVET SHAVERS

C	D156-S-20000	1465994	20000	–	9/16	14.3	2.2	1.0	9.13	232	20	9.3	1/4"	3/8	10	77
D	D156-P-20000	1466004	20000	–	9/16	14.3	2.4	1.1	7.99	203	20	9.3	1/4"	3/8	10	78

Accessories

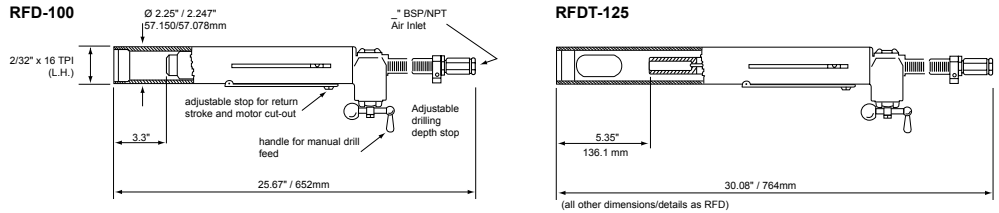

RFD-100 / RFDT-125

ACCESSORIES INCLUDED

	PART NO.	
	RFD	RFDT
• Chuck with key capacity 1/2" (13mm)	29142	
• Extended Nose (1" x 14 TPI LH nose thread)	251043	
• Bayonet Plate – 1.50" (45mm) centers	251063	
• Bayonet Plate – 2.99" (76mm) centers		35323

OPTIONAL ACCESSORIES

	PART NO.
	RFD
• Chuck Key	29242

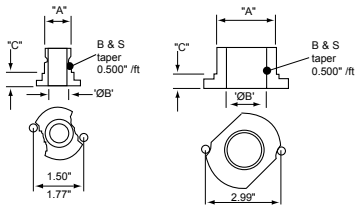

Bayonet Plates

	'A'	'ØB'	'C'	PART NO.
• Locating centers – 1.50" (38mm)	3/4" x 16 TPI (LH)	0.559" (14.2mm)	0.374" (9.5mm)	251053
• Locating centers – 1.50" (38mm)	7/8" x 20 TPI (LH)	0.559" (14.2mm)	0.374" (9.5mm)	30623
• Locating centers – 1.77" (45mm)	1" x 14 TPI (LH)	0.75" (19.05mm)	0.374" (9.5mm)	251063
• Locating centers – 1.77" (45mm)	1 1/8" x 20 TPI (LH)	0.75" (19.05mm)	0.374" (9.5mm)	31113
• Locating centers – 2.99" (76mm)	2 3/32" x 16 TPI (LH)	1.50" (38.1mm)	0.50" (12.7mm)	35323

Nose Attachment 1

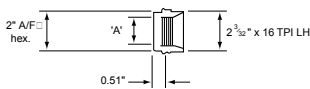

Nose Attachment 2

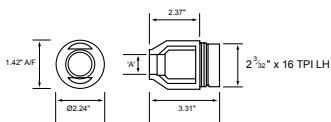

Nose Attachment 3

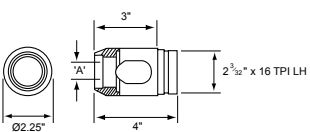

Nose Attachments

Nose type	To suit bayonet plate centers	Thread 'A'	PART NO.
1	1.50" (38mm)	3/4" x 16 TPI (LH)	235773
2	1.50" (38mm)	3/4" x 16 TPI (LH)	251033
2	1.77" (45mm)	1" x 14 TPI (LH)	251043
3	–	1 1/4" x 12 TPI (LH)	235213
3	–	1 1/2" x 12 TPI (LH)	235223
3	–	2" x 16 TPI (LH)	235343

Extension Tubes

Nominal stroke available to drill	Length 'A'	PART NO.
2.36" (60mm)	5.90" (150mm)	250933
3.15" (80mm)	6.69" (170mm)	250923

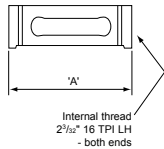

Jig Plates

Centres 'A'	PART NO.	
	LOCATING STUD	SCREW
1.50" (38mm)	17632	17642
1.77" (45mm)	17632	17642
2.99" (76mm)	18422	18432

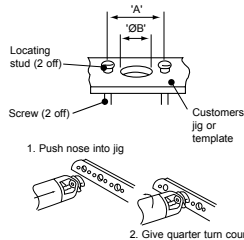

For dimension 'ØB' please ask for details of our range of drill bushings.

Rack Feed Drills

- The Rack Feed Drill is a semi-fixtured (nose mounted) portable drilling unit. Utilizing a manual feed through an integral "rack and pinion" mechanism to accommodate the approach drilling and retract cycles. This provides the user with complete control of the feed rate during drilling and allows the user to "feel" the feed rate required. Versatile and flexible, especially when drilling laminates and sandwich materials.
- RFD is suitable for drilling/reaming various materials used in the Aerospace industries e.g. Inconel, Titanium, Steel, Aluminium and Composites.
- A wide speed range from 60 rpm to 2800 rpm is available allowing the best speed to be selected to suit the application.
- RFD-100 provides 102mm (4") of adjustable working stroke length with a 13mm (1/2") chuck capacity.
- RFDT-125 provides 127mm (5") of adjustable working stroke length with a No. 2 Morse Taper drive spindle.
- Automatic motor start/stop – can be set to operate at any point within stroke setting for maximum economy of air.
- Various nose configurations can be provided.



RFD Selection

DRILL DIA.	MATERIAL			
	Inconel	Titanium	Mild Steel	Aluminium
	Tool type – r/min			
3mm 1/8"	RFD-330/500 RFDT-330/500	RFD-500 RFDT-500	RFD-2800	RFD-2800
5mm 3/16"	RFD-140/330 RFDT-140/330	RFD-330/500 RFDT-330/500	RFD-1850	RFD-2800
6mm 1/4"	RFD-140 RFDT-140	RFD-140/330 RFDT-140/330	RFD-800 RFDT-800	RFD-1850
8mm 5/16"	RFD-140 RFDT-140	RFD-140/330 RFDT-140/330	RFD-800 RFDT-800	RFD-800 RFDT-800
10mm 3/8"	RFD-85/140 RFDT-85/140	RFD-140 RFT-140	RFD-800 RFDT-800	RFD-800 RFDT-800
13mm 1/2"	RFD-60/85 RFDT-60/85	RFD-85/140 RFDT-85/140	RFD-500 RFDT-500	RFD-800 RFDT-800
16mm 5/8"		RFD-85/140 RFDT-85/140	RFD-330 RFDT-330	RFD-800 RFDT-800
19mm 3/4"		RFD-60/85 RFDT-60/85	RFD-85/140 RFDT-85/140	RFD-330/500 RFDT-330/500
25mm 1"			RFD-60/85 RFDT-60/85	RFD-140/330 RFDT-140/330

Use selection data as a guide only

All RFD-100 models supplied with 1/2" (13mm) chuck fitted

MODEL	PART NUMBER	FREE SPEED	MAX STROKE		OUTPUT SPINDLE	WEIGHT		AIR CONSUMPTION		AIR INLET	MIN. HOSE BORE		SOUND LEVEL
			r/min	in.		mm	lb	kg	cfm		l/s	BSP/NPT	
RFD-100-2800	681214	2800	4	102	1/2"-20 UN	8.6	3.9	25	11.8	1/4	3/8	10	88
RFD-100-1850	681394	1850	4	102	1/2"-20 UN	8.6	3.9	25	11.8	1/4	3/8	10	88
RFD-100-800	680084	800	4	102	5/8"-16 UN	8.6	3.9	25	11.8	1/4	3/8	10	88
RFD-100-500	680164	500	4	102	5/8"-16 UN	8.6	3.9	25	11.8	1/4	3/8	10	88
RFD-100-330	681244	330	4	102	5/8"-16 UN"	8.6	3.9	25	11.8	1/4	3/8	10	88
RFD-100-140	1457364	140	4	102	5/8"-16 UN	8.6	3.9	25	11.8	1/4	3/8	10	88
RFD-100-85	1457374	85	4	102	5/8"-16 UN	8.6	3.9	25	11.8	1/4	3/8	10	88
RFD-100-60	1457384	60	4	102	5/8"-16 UN	8.6	3.9	25	11.8	1/4	3/8	10	88
RFDT-125-800	1445654	800	5	127		12.1	5.5	25	11.8	1/4	3/8	10	88
RFDT-125-500	1445664	500	5	127	No. 2	12.1	5.5	25	11.8	1/4	3/8	10	88
RFDT-125-330	1445674	330	5	127	Morse	12.1	5.5	25	11.8	1/4	3/8	10	88
RFDT-125-140	1445504	140	5	127	Taper	12.1	5.5	25	11.8	1/4	3/8	10	88
RFDT-125-85	1445514	85	5	127		12.1	5.5	25	11.8	1/4	3/8	10	88
RFDT-125-60	1445524	60	5	127		12.1	5.5	25	11.8	1/4	3/8	10	88

Accessories

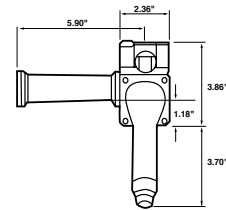
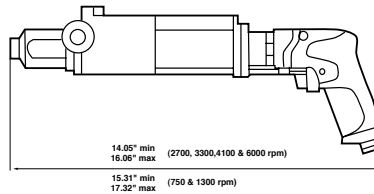
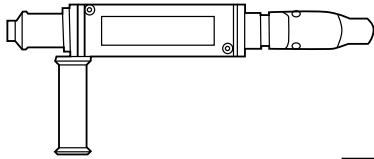

CFD-DR750-..

ACCESSORIES INCLUDED

ITEM	PART NO.		
	6000 & 4100 r/min	3300, 2700 & 1300 r/min	750 r/min*
1 Chuck (without key) capacity 5/16" (8mm)	410203		
• Chuck Key	410213		
1 Chuck with key capacity 3/8" (10mm)		31132	
• Chuck Key		29232	
• No chuck*			
2 Tooling Tube 3/4" - 16 UN LH thread	469883	469883	3/8"-24 spindle 469883
• Sound reduction kit (75 dB(A))	tba	tba	tba

OPTIONAL ACCESSORIES

	PART NO.
3 Tooling Tube blank (for local customisation)	471873
• Hydraulic Control Unit – 25mm 1" stroke	91942
• Hydraulic Control Unit – 50mm 2" stroke	91952
• Tamper proof HCU cap	110632
• Micrometer depth adjustment module	tba
• Dust extraction kit	tba
• Self colleting mandrel – nose mount	tba
4 Collet Spindle – max capacity 3/8" (Ø9.5mm)	6155230230
5 Collet Nut	6156071440
6 Collet – capacity 1/8" (Ø2.4 to 3.2mm)	6155260610
6 Collet – capacity 7/32" (Ø5.2 to 6.0mm)	6155260620
6 Collet – capacity 1/4" (Ø5.55 to 6.35mm)	6155260630
6 Collet – capacity 5/16" (Ø7.2 to 8.0mm)	6155260640
6 Collet – capacity 3/8" (Ø8.7 to 9.5mm)	6155260640

Bayonet Plates

	'A'	'ØB'	'C'	PART NO.
• Locating centers – 1.50" (38mm)	3/4" x 16 TPI (LH)	0.559" (14.2mm)	0.374" (9.5mm)	251053
• Locating centers – 1.50" (38mm)	7/8" x 20 TPI (LH)	0.559" (14.2mm)	0.374" (9.5mm)	30623
• Locating centers – 1.77" (45mm)	1" x 14 TPI (LH)	0.75" (19.05mm)	0.374" (9.5mm)	251063
• Locating centers – 1.77" (45mm)	1 1/8" x 20 TPI (LH)	0.75" (19.05mm)	0.374" (9.5mm)	31113

* Tooling tube (3/4" - 16 UN LH) is suitable for use with 21000 series drill bushings.

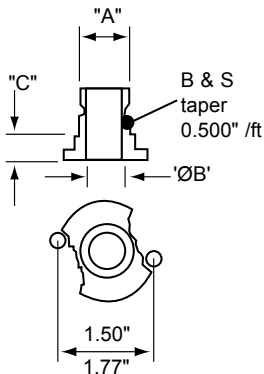

Bushings available on request.
Please ask for further details.



CFD – Portable Feed Drill



A

How to select ...

DR750-P6000-C8
Drill power unit

fitted with

Constant Feed
Module

+

Hydraulic Control
Unit

Pt No. 470153

Pt No. 91942 – 25mm stroke
Pt No. 91952 – 50mm stroke

MODEL	PART NUMBER	FREE SPEED	STD. CHUCK SIZE	
		r/min	in.	mm
DR750-P6000	1465124	6000	5/16	8
DR750-P4100	1465114	4100	5/16	8
DR750-P3300	1465104	3300	3/8	10
DR750-P2700	1465094	2700	3/8	10
DR750-P1300	1465084	1300	3/8	10
DR750-P750	1465074	750	–	–

For alternative chuck, or collet spindle,
please select from accessories section.

Drilling speed selection guide:

FREE SPEED	TITANIUM	STAINLESS STEEL	SOFT CAST IRON, MILD STEEL	ALUMINIUM, BRASS, COPPER, BRONZE	COMPOSITE
r/min		30-50ft/min	65-115ft/min	165-265ft/min	165-330ft/min
Drill Ø (mm)					
6000	–	–	–	5/32"	3/16"
4100	–	–	–	1/4"	5/16"
3300	–	–	1/8"	5/16"	3/8"
2700	–	–	5/32"	3/8"	–
1300	5/128-5/64"	5/32"	11/32"	–	–
750	1/8"	9/32"	3/8"	–	–

Max. working stroke 2"

Sound level: 75dB(A) with silencing kit fitted

Air inlet: 1/4" BSP/NPT. Vibration level: <2.5 m/s².

MODEL	FREE SPEED	STD. CHUCK SIZE		MOTOR POWER		DYNAMIC THRUST		WEIGHT		AIR FLOW		MIN. HOSE BORE	
	r/min	in.	mm	Hp	kW	lbf	N	lb	kg	cfm	l/s	in.	mm
CFD-DR750-P6000	6000	3/8	8	1.00	0.75	146	650	1.70	3.75	30	14	3/8	10
CFD-DR750-P4100	4100	3/8	8	1.00	0.75	146	650	1.70	3.75	30	14	3/8	10
CFD-DR750-P3300	3300	3/8	10	1.00	0.75	146	650	1.70	3.75	30	14	3/8	10
CFD-DR750-P2700	2700	3/8	10	1.00	0.75	146	650	1.70	3.75	30	14	3/8	10
CFD-DR750-P1300	1300	3/8	10	1.00	0.75	146	650	1.93	4.25	30	14	3/8	10
CFD-DR750-P750	750	3/8	–	1.00	0.75	146	650	1.93	4.25	30	14	3/8	10

Accessories

Model	A		B	
	in.	mm	in.	mm
CP-4450-2	8.4	213	1.26	32
CP-4450-3	8.9	226	1.26	32
CP-4450-4	9.9	251	2.36	60

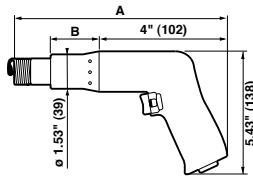

Model	A	
	in.	mm
CP-4444-RURAB	6.7	170
CP-4444-RUSAB	7.3	186
CP-4444-RUTAB	8.3	211
CP-4447-RUSAB	8.9	227
CP-4447-RUTAB	9.9	252
CP-4447-RUVAB	11.9	303

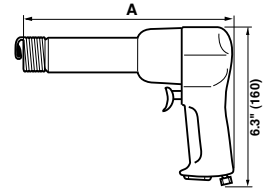

CP-4450 / CP-4444 / CP-4447

ACCESSORIES INCLUDED

ITEM	PART NO.	
	CP-4444	CP-4447
A Zip-Quick Retainer	A046094	
B Beehive Retainer	A074498	
C Light Wire Quick-Change Retainer	A092007	
D Air Inlet Regulation	CA085203	CA085203
E Wire Quick-Change Retainer		A050282
F Beehive Retainer		A047096

OPTIONAL ACCESSORIES

ITEM	PART NO.
	CP-4447
G Nail Driving Attachment for 20-60 Penny Nail Size (for CP-4447 RUSAB)	P042448
H Nail Driving Attachment for 12" Spikes (for CP-4447 RUVAB)	P047810

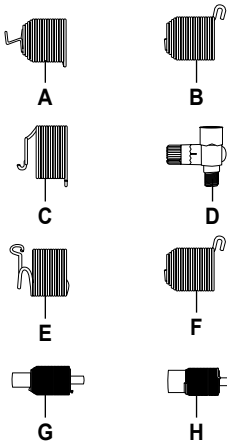

CP-4450 / CP-4444

Type I Rivet Sets \varnothing 0.401"

RIVET HEAD CUPPING	3/32"	1/8"	5/32"	3/16"	1/4"
• Round (AN-430)	P089206	P089207	P089208	9089209	P089210*
• Brazier (AN-455)	P089211	P089212	P089213		P089215*
• Universal (AN-470)	P089221	P089222	P089223	P089224	P089225*
• Soft Blank Set	P071108				
• Hardened Blank Set	P080178				

* Must use Light Wire Quick-Change Retainer, A-092007 with these sets

CP-4450 / CP-4444 / CP-4447

Type I Flush Rivet Sets \varnothing 0.401" & 0.498"

	in.	A	mm	CP-4450/4444 .401 SHANK	CP-4447 .498 SHANK
•	1"		25.4	A046090	
•	1 1/4"		31.8	A089232	A047091
•	1 1/2"		38.1	A089233	
•	1 3/4"		44.5	A046091	

CP-4447

Type D Rivet Sets \varnothing 0.498"

RIVET HEAD CUPPING	RIVET SET PART NO. BY RIVET BODY DIA.		
	3/16"	1/4"	5/16"
• Round (AN-430)	P089240	P089241	P089242*
• Brazier (AN-455)	P089244	P089245	
• Modified Brazier (AN-456)	P089248	P089244	P089245*
• Universal (AN-470)	P089252	P089253	P089254*
• Soft Blank Set	P070995		P089254*
• Hardened Blank Set	P080198		

* Must use Standard Wire Quick-Change Retainer, A-050282

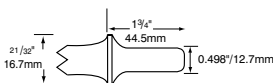
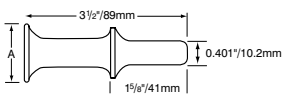
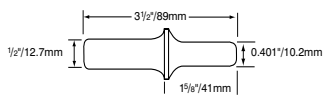

Riveting Hammers



A



B



C



Min. hose bore: $\frac{3}{8}$ " (10mm)

PICTURE REF	MODEL	PART NUMBER	AIRFRAME REF	BLOW PER MINUTE	BORE & STROKE	CHISEL SHANK OPENING	CAPACITY COLD RIVETS		LENGTH		WEIGHT		AIR INLET	SOUND LEVEL	SOUND POWER	VIBRATION LEVEL
							Dural	Steel	in.	mm	lb	kg				

RIVETING HAMMERS – VIBRATION REDUCED

A	CP-4450-2	T025189	2X	2580	$\frac{1}{2}$ "x2"	0.401"	$\frac{1}{8}$ "	$\frac{3}{32}$ "	3.2mm	2.4mm	8.4	213	2.7	1.2	$\frac{1}{4}$	92	103	<2.5
A	CP-4450-3	T025190	3X	2160	$\frac{1}{2}$ "x3"	0.401"	$\frac{3}{16}$ "	$\frac{5}{32}$ "	4.8mm	4.0mm	8.9	226	2.8	1.3	$\frac{1}{4}$	92	103	<2.5
A	CP-4450-4	T025191	4X	1740	$\frac{1}{2}$ "x4"	0.401"	$\frac{1}{4}$ "	$\frac{3}{16}$ "	6.4mm	4.8mm	9.9	251	3.2	1.4	$\frac{1}{4}$	92	103	<2.5

RIVETING HAMMERS – STANDARD

B	CP-4444-RURAB	T022961	2X	2580	$\frac{1}{2}$ "x2"	0.401"	$\frac{1}{8}$ "	$\frac{3}{32}$ "	3.2mm	2.4mm	6.7	170	2.2	1.0	$\frac{1}{4}$	94	105	4.5
B	CP-4444-RUSAB	T022962	3X	2160	$\frac{1}{2}$ "x3"	0.401"	$\frac{3}{16}$ "	$\frac{5}{32}$ "	4.8mm	4.0mm	7.3	186	2.3	1.1	$\frac{1}{4}$	94	105	4.4
B	CP-4444-RUTAB	T022963	4X	1740	$\frac{1}{2}$ "x4"	0.401"	$\frac{1}{4}$ "	$\frac{3}{16}$ "	6.4mm	4.8mm	8.3	211	2.75	1.3	$\frac{1}{4}$	99	110	5.1
C	CP-4447-RUSAB	T022965	5XB	1560	$\frac{3}{4}$ "x2 $\frac{11}{16}$ "	0.498"	$\frac{1}{4}$ "	$\frac{3}{16}$ "	6.4mm	4.8mm	8.9	227	4.7	2.2	$\frac{1}{4}$	96	107	10.1
C	CP-4447-RUTAB	T022912	9XB	1140	$\frac{3}{4}$ "x2 $\frac{7}{8}$ "	0.498"	$\frac{5}{16}$ "	$\frac{1}{4}$ "	7.9mm	6.4mm	9.9	252	5.1	2.3	$\frac{1}{4}$	92	103	9.7
C	CP-4447-RUVAB	T022964	7XB	900	$\frac{3}{4}$ "x5 $\frac{13}{16}$ "	0.498"	$\frac{3}{8}$ "	$\frac{5}{16}$ "	9.5mm	7.9mm	11.9	303	9.0	2.7	$\frac{1}{4}$	92	102	5.5

Compression Tools – Selection



CP-0214 – C Yoke

- Single and Tandem cylinder options
- Riveting Capacity –
 - ø 1/8" 3.2mm (single cylinder)
 - ø 3/16" 4.8mm (tandem cylinder)
- Lock-off throttle – reduces the risk of accidental operation



CP-0341 – C Yoke

- Patented 'Pneudraulic™' air-hydraulic riveter
- Riveting Capacity –
 - ø 9/32" 7.14mm
- Lock-off throttle – reduces the risk of accidental operation
- Versatile – can accommodate various rivet lengths and joint thickness by adjustment of air pressure (reducing setting times and eliminates the need to use set length spacer shims with the rivet sets)



CP-0351 – C Yoke

- Single and Tandem cylinder options
- Riveting Capacity –
 - ø 3/16" 4.8mm (single cylinder)
 - ø 1/4" 6.4mm (tandem cylinder)
- Actuation throttle guard – reduces the risk of accidental operation
- Short stroke adjustment – aids positioning of the tool (limits the return travel of the moving set of the tool on the rivet to reduce the starting clearance between rivet and rivet sets)



CP-0214 – Alligator Jaw

- Single and Tandem cylinder options
- Riveting Capacity –
 - ø 1/8" 3.2mm (single cylinder)
 - ø 3/16" 4.8mm (tandem cylinder)
- Lock-off throttle – reduces the risk of accidental operation



CP-0351 – Alligator Jaw

- Single and Tandem cylinder options
- Riveting Capacity –
 - ø 9/32" 4.0mm (single cylinder)
 - ø 1/4" 6.4mm (tandem cylinder)
- Actuation throttle guard – reduces the risk of accidental operation
- Short stroke adjustment – aids positioning of the tool (limits the return travel of the moving set of the tool on the rivet to reduce the starting clearance between rivet and rivet sets)

Selection Criteria

• Type of Rivet

- Rivet material
- Rivet body diameter
- Rivet length before and after compression
- Force required to compress rivet (if known)

• What material is the rivet made from?

• What size is the rivet?

• What is the form of the rivet head?

• Components to assemble

- Access to rivet on assembly

• Open access (up to 2 1/8" / 54mm reach)

– 'C' Yoke tool

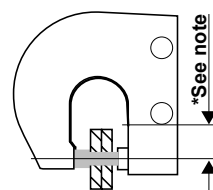

• Restricted access (up to 9 1/8" / 232mm reach)

– 'Alligator' Jaw tool

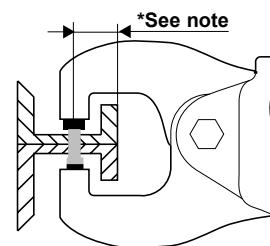

- **Note:** the amount of reach required is determined by the distance from the rivet centreline to the accessible edge of the workpiece

Compression Tools – Selection

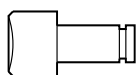

Compression Rivet Sets

(Complete with retaining rings)

Minimum Order: 6 of any part number.

Note: The illustration above shows one rivet set. Two rivet sets are required to be used per tool. Part numbers are for one rivet set only.

SELECTING RIVET SETS TO FIT CP-0214, CP-0341 & CP-0351 RIVETERS

To develop maximum power, the riveter must drive (set) the rivet at the end of the riveter's stroke (with the exception of the CP-0341 which develops max power throughout its full stroke).

For maximum power the combined length of the two rivet sets must be of the correct length.

Determine the correct lengths as follows:

1) When two cupped rivet sets are used:

The length of the body dimensions of the rivet sets (A_1 , A_2) should equal the closed height dimension of the yoke H minus the total thickness of material being riveted together.

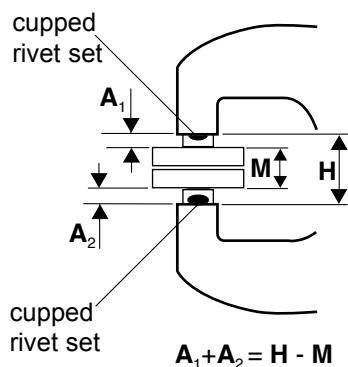

2) When one cupped set and one flush set are used:

The length of the body dimensions of the two rivet sets (A_1 , A_2) should equal the closed height dimension of the yoke (H) minus the total thickness of the material being riveted (M) and the height of the finished rivet head (Z) compressed by the flush set (A).

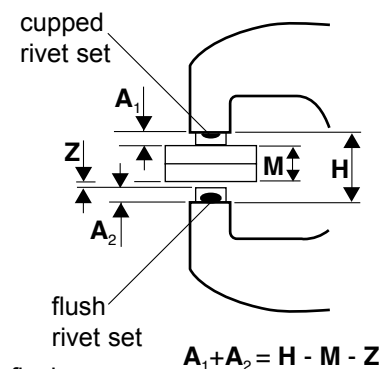

3) When two flush sets are used:

The length of the body dimensions of the two rivet sets (A_1 , A_2) should equal the closed height dimension of the yoke (H) minus the overall length of the rivet (L) after it is compressed.

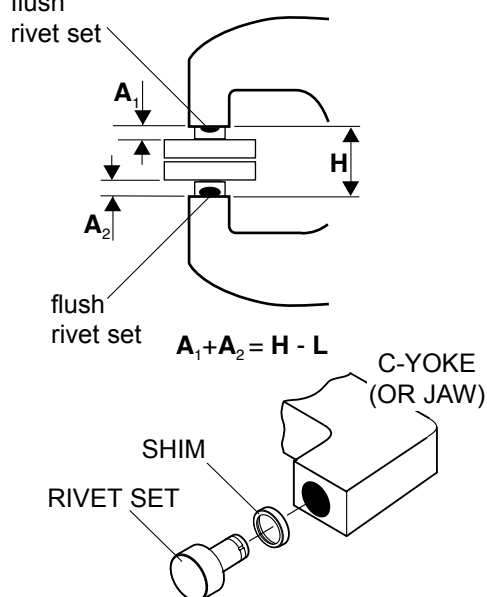

If necessary, select rivet sets a little short and shim to the correct length using spacer shims.

Compression Tools – Rivet Sets

RIVET DIAMETER		'A' BODY LENGTH		AN-435 BUTTON	AN-430 ROUND	AN-455 BRAZIER	AN-456 MODIFIED BRAZIER	AN-470 UNIVERSAL	AN-442 FLAT
in.	mm	in.	mm	part no.	part no.	part no.	part no.	part no.	part no.

CR-1 SHANK RIVET SETS FOR CP-0214 & CP-0351 – CUPPED SETS

(C-Yoke tools – CP-0214 CELEL, FALEL, CUDEL, FUEL + all Alligator Yoke tools)

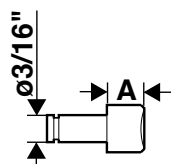

3/32"	2.4	1/4"	6.4	P091601	P089370	P089390	P089410	P089430	P091621
3/32"	2.4	3/8"	9.5	P091602	P089371	P089391	P089411	P089431	P091622
3/32"	2.4	1/2"	12.7	–	–	–	P089412	P089432	P091623
1/8"	3.2	1/4"	6.4	P091606	P089375	P089395	P053826	P089435	P091626
1/8"	3.2	3/8"	9.5	P091607	P089376	–	P053827	P089436	P091627
1/8"	3.2	1/2"	12.7	P091608	P089377	P089397	–	P089437	P091628
5/32"	4.0	1/4"	6.4	P091611	P089380	P089400	P053831	P089440	P091631
5/32"	4.0	3/8"	9.5	P091612	P089381	P089401	P053832	P089441	P091632
5/32"	4.0	1/2"	12.7	P091613	P089382	P089402	P053833	P089442	P091633
3/16"	4.8	1/4"	6.4	P091616	P089385	P089405	P053836	P089445	P091636
3/16"	4.8	3/8"	9.5	P091617	P089386	P089406	P053837	P089446	P091637
3/16"	4.8	1/2"	12.7	P091618	P089387	P089407	P053838	P089447	P091638

CR-2 SHANK RIVET SETS FOR CP-0214 & CP-0341 – CUPPED SETS

(C-Yoke tools – CP-0214 SETEL, KETEL + CP-0341 CUDEL)

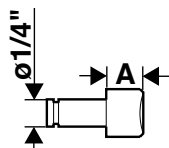

1/8"	3.2	1/4"	6.4	–	–	–	–	P089510	P091661
1/8"	3.2	3/8"	9.5	P091642	–	–	–	P089511	–
1/8"	3.2	1/2"	12.7	–	–	–	–	P089512	P091663
5/32"	4.0	1/4"	6.4	–	P089455	–	–	P089515	–
5/32"	4.0	3/8"	9.5	–	–	–	–	P089516	P091667
5/32"	4.0	1/2"	12.7	P091648	–	–	–	P089517	P091668
3/16"	4.8	1/4"	6.4	–	P089460	P089480	–	P089520	P091671
3/16"	4.8	3/8"	9.5	–	P089461	P089481	–	P089521	P091672
3/16"	4.8	1/2"	12.7	P091653	–	P089482	–	P089522	P091673
1/4"	6.4	1/4"	6.4	–	P089465	P089485	–	P089525	P091676
1/4"	6.4	3/8"	9.5	–	P089466	P089486	–	P089526	–
1/4"	6.4	1/2"	12.7	–	P089467	–	–	P089527	P091678

SHANK SIZE	'A' BODY LENGTH					
	1/8"	1/4"	3/8"	1/2"	5/8"	3/4"

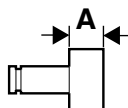

FLUSH SETS for any rivet size

CR-1 (ø 3/16")	P089495	P089496	P089497	P089498	P089499	P089500
CR-2 (ø 1/4")	–	P089501	P089502	P089503	P089504	P089505

TYPE OF RIVET SET SHANK	'A' LENGTH		BODY DIAMETER		PART NUMBER
	in.	mm	in.	mm	

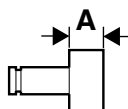

SOFT SET BLANKS

CR-1 (ø 3/16")	3/4"	19.1	5/8"	15.9	P093672
CR-2 (ø 1/4")	3/4"	19.1	3/4"	19.1	P093673

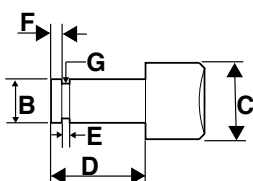

* 'C' dimension is for flush set only. 'C' varies on cupped sets according to rivet size and type of head.

TYPE OF RIVET SET SHANK	B		C*		D		E		F		G	
	in.	mm	in.	mm	in.	mm	in.	mm	in.	mm	in.	mm

SHANK DIMENSIONS FOR RIVET SETS

For CP-0214, CP-0351 and CP-0341 Compression Riveters

CR-1 (ø 3/16")	0.187-0.186	4.75-4.72	1/2	12.7	1/2	12.7	0.136-0.133	3.45-3.38	1/16	1.6	0.127-0.123	3.23-3.12
CR-2 (ø 1/4")	0.249-0.248	6.42-6.40	5/8	15.9	5/8	15.9	0.136-0.133	3.45-3.38	3/32	2.4	0.189-0.185	4.80-4.70

Compression Tools – Riveting



A



B



C



D



E

For detailed dimensions please refer to "Technical Data" – page 42

PICTURE REF	MODEL	PART NUMBER	CAPACITY				STANDARD YOKE DIMENSIONS				MAX FORCE		MOVING PLUNGER			
			ALUM.		STEEL		REACH		CLOSED HEIGHT		(90 psi/6.2 bar)		MAX. TRAVEL		FINAL PART OF STROKE AT MAX. FORCE	
			in.	mm	in.	mm	in.	mm	in.	mm	lb	kN	in.	mm	in.	mm
A	CP0214CELEL	T012344	1/8	3.2	3/32	2.4	1 1/2	38.1	1 1/16	17.5	3,000	13.35	9/16	14.3	0.050	1.3
A	CP0214SETEL	T023474	1/8	3.2	3/32	2.4	1 1/2	38.1	1 1/16	17.5	3,000	13.35	9/16	14.3	0.050	1.3
A	CP0214FALEL	T013152	3/16	4.8	5/32	4.0	1 1/2	38.1	1 1/16	17.5	6,000	26.70	9/16	14.3	0.063	1.6
A	CP0214KETEL	T023475	3/16	4.8	5/32	4.0	1 1/2	38.1	1 1/16	17.5	6,000	26.70	9/16	14.3	0.063	1.6
B	CP0351CUDEL	T008955	3/16	4.8	5/32	4.0	2 1/8	54.0	25/32	19.8	6,000	26.70	9/16	14.3	0.125	3.2
B	CP0351FUDEL	T012608	1/4	6.4	7/32	5.6	2 1/8	54.0	25/32	19.8	12,000	53.40	9/16	14.3	0.125	3.2
D	CP0341CUDEL	T022512	9/32	7.1	1/4	6.4	2 1/8	54.0	1	25.4	13,500	60.10	1 1/4	31.8	Full stroke	
C	CP0214ANFEL	T018671	3/32	2.4	3/32	2.4	2 1/4	57.1	7/8	22.2	2,200	9.79	7/16	11.1	0.094	2.4
C	CP0214ANGEL	T018672	3/32	2.4	1/16	1.6	3	76.2	7/8	22.2	1,800	8.01	1 1/4	31.8	0.056	1.4
C	CP0214ANBEL	T012343	1/8	3.2	3/32	2.4	1 1/2	38.1	7/8	22.2	3,000	13.35	5/8	15.9	0.050	1.3
C	CP0214ENGEL	T018164	1/8	3.2	3/32	2.4	3	76.2	7/8	22.2	3,400	15.13	1 1/4	31.8	0.104	2.6
E	CP0351ASKEL	T007773	1/8	3.2	3/32	2.4	5	127.0	7/8	22.2	3,400	15.13	1 3/8	34.0	0.188	4.8
E	CP0351ASVEL	T009582	1/8	3.2	3/32	2.4	9 1/8	232.0	3/4	19.1	3,000	13.35	1 11/16	42.9	0.063	1.6
C	CP0214ENFEL	T018163	5/32	4.0	1/8	3.2	2 1/4	57.1	7/8	22.2	4,300	19.14	7/8	22.2	0.094	2.4
E	CP0351ASGEL	T007783	5/32	4.0	1/8	3.2	2 7/8	73.0	7/8	22.2	5,200	23.14	5/8	15.9	0.125	3.2
C	CP0214ENBEL	T018678	3/16	4.8	5/32	4.0	1 1/2	38.1	7/8	22.2	6,000	26.70	5/8	15.9	0.063	1.6
E	CP0351ESKEL	T012603	3/16	4.8	5/32	4.0	5	127.0	7/8	22.2	6,800	30.26	1 3/8	34.0	0.188	4.8
E	CP0351ESREL	T012604	3/16	4.8	5/32	4.0	7	178.0	1 1/2	38.1	6,000	26.70	1 11/16	42.9	0.188	4.8
E	CP0351ESVEL	T012605	3/16	4.8	5/32	4.0	9 1/8	232.0	3/4	19.1	6,000	26.70	1 11/16	42.9	0.063	1.6
E	CP0351ESGEL	T012602	1/4	6.4	3/16	4.8	2 7/8	73.0	7/8	22.2	10,400	46.28	5/8	15.9	0.125	3.2

Compression Tools – Sheet Metal Punch

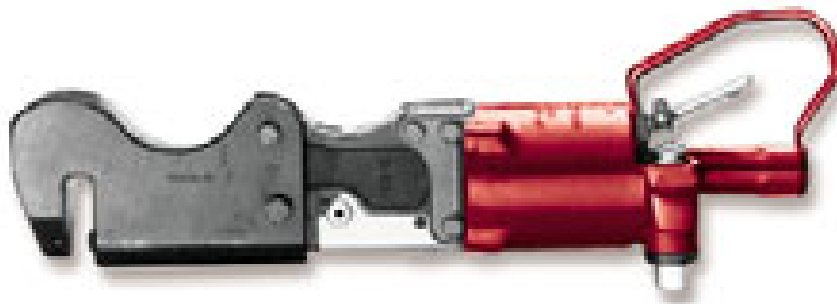

CP-0351-PU

- Punching Capacity:
 \varnothing $\frac{3}{16}$ " (4.8mm) in aluminium
 through $\frac{3}{16}$ " (4.8mm) material thickness
- Actuation throttle guard:
 reduces the risk of accidental operation
- Use for a wide range of punching operations where it is preferable to take the tool to the job.
 e.g. large structures such as truck trailers

Capacity:

Maximum hole is \varnothing $\frac{1}{2}$ " (13mm) relative to material and thickness.

Within maximum force of 5,400 lbs – 24.0 kN, material thickness should not exceed hole diameter.

To determine force required use formula: **$F = 3.14 \times D \times T \times S$**

where "F" is force (lbs); "D" is hole diameter (in.); "T" is thickness of material (in.); "S" is tensile strength of material (psi) or "F" is force (N); "D" is hole diameter (mm); "T" is thickness of material (mm); "S" is tensile strength of material (N/mm²)

Standard Equipment supplied with tool:

(1) Punch – Part No. P041307, (1) Die – Part No. P043009
 and (1) stripping collar – Part No. P043109
 for punching hole for \varnothing $\frac{3}{16}$ " (4.8mm) rivet in $\frac{3}{16}$ " (4.8mm)
 thick aluminium.

MODEL	PART NUMBER	MAX. MATERIAL THICKNESS ALUM.		HOLE DIAMETER		MAX. DISTANCE EDGE OF SHEET TO HOLE CENTRELINE		MAX. PUNCHING FORCE (90 psi/6.2 bar)		WORK CLEARANCE PUNCH RETRACTED	
		in.	mm	in.	mm	in.	mm	lb	kN	in.	mm
CP-0351PU	T013417	$\frac{3}{16}$	4.8	$\frac{3}{16}$	4.8	$\frac{17}{8}$	47.6	5400	24.0	$\frac{1}{2}$	12.7

Compression Tools – Edge Former



CP-0351-CABH-DY

- Forming Capacity (max material thickness) – \varnothing 1/4" (6.4mm)
- Rotary Suspension Bail fitted – eases handling and orientation of tool
- Use for a wide range of flattening of spot welded flanges and removing bends
- Custom yokes and dies can be used for crimping and staking operations
- Automatic cycling frequency is adjustable from 1 cycle per throttle actuation to, up to 200 cycles per minute while the throttle actuation is maintained

Standard Equipment supplied with tool:

(1) Yoke – Part No. P059557, (1) Die – Part No. P059556 and (1) Ball Bearing Suspension Bail – Part No. P010245

MODEL	PART NUMBER	MAX. MATERIAL THICKNESS ALUM.		MAX. CYCLES PER MINUTE	REACH		MAX. COMPRESSIVE FORCE (90 psi/6.2 bar)	
		in.	mm		in.	mm	lb	kN
CP-0351-CABH-DY	T020475	1/4	6.4	200	9/16	14.4	6000	26.7

Compression Tools – Technical Data

Jaw & Yoke Terminology:

(rivet sets are not in place in this illustration)

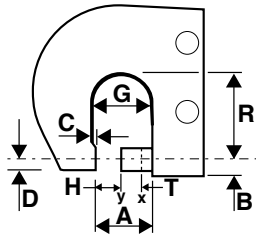

- A Throat gap
- B Upper offset
- C Anvil work clearance
- D Lower offset
- G Total yoke gap
- H Closed height
- R Reach
- T Travel

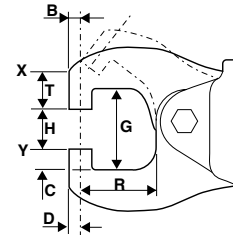

- x Extreme open position
- y Extreme closed position

C Yoke Model	A		C		D		G		H		R	
	in.	mm	in.	mm	in.	mm	in.	mm	in.	mm	in.	mm
CP0214CELEL	1 1/4	32	-	-	3/16	5	1 1/4	32	11 1/16	17.5	1 1/2	38
CP0214FALEL	1 1/4	32	-	-	3/16	5	1 1/4	32	11 1/16	17.5	1 1/2	38
CP0351CUDEL	1 17/32	39	-	-	7/32	5.5	1 3/32	29	25 3/32	20	2 1/8	54
CP0351FUDEL	1 17/32	39	-	-	7/32	5.5	1 3/32	29	25 3/32	20	2 1/8	54
CP0341CUDEL	2 1/4	57	1/8	3	11 1/32	9	2 3/4	70	1	25	2 1/8	54

Alligator Jaw Model	A		C		D		G		H		R	
	in.	mm	in.	mm	in.	mm	in.	mm	in.	mm	in.	mm
CP0214ANGEL	2 1/8	54	-	-	7/32	5.5	2 1/8	54	7/8	22	3	76
CP0214ENGEL	2 1/8	54	-	-	7/32	5.5	2 1/8	54	7/8	22	3	76
CP0214ANFEL	1 7/8	48	-	-	7/32	5.5	2 1/8	54	7/8	22	2 1/4	57
CP0214ANFEL	1 7/8	48	-	-	7/32	5.5	2 1/8	54	7/8	22	2 1/4	57
CP0214ANBEL	1 1/2	38	-	-	7/32	5.5	1 5/8	41	7/8	22	1 1/2	38
CP0214ENBEL	1 1/2	38	-	-	7/32	5.5	1 5/8	41	7/8	22	1 1/2	38
CP0214SETEL	-	-	-	-	-	-	-	-	-	-	-	-
CP0214KETEL	-	-	-	-	-	-	-	-	-	-	-	-
CP0351ASVEL	2 7/16	62	-	-	7/32	5.5	2 3/16	56	3/4	19	9 1/8	232
CP0351ESVEL	2 7/16	62	-	-	7/32	5.5	2 3/16	56	3/4	19	9 1/8	232
CP0351ESREL	3 3/16	81	-	-	7/32	5.5	2	51	1 1/2	38	7	178
CP0351ASKEL	2 1/4	57	-	-	7/32	5.5	1 5/8	41	7/8	22	5	127
CP0351ESKEL	2 1/4	57	-	-	7/32	5.5	1 5/8	41	7/8	22	5	127
CP0351ASGEL	1 1/2	38	-	-	7/32	5.5	1 5/8	41	7/8	22	2 1/8	73
CP0351ESGEL	1 1/2	38	-	-	7/32	5.5	1 5/8	41	7/8	22	2 1/8	73

Air inlet: 1/4" NPTF

MODEL	CYLINDER TYPE	RIVET SET TYPE	LENGTH		WEIGHT		SOUND LEVEL	SOUND POWER
			in.	mm	lb	kg		
CP0214ANBEL	Single	CR-1 (Ø 3/16")	9 3/16	233	3 3/4	1.7	90	101
CP0214ANFEL	Single	CR-1 (Ø 3/16")	10	254	4 1/4	1.9	90	101
CP0214ANGEL	Single	CR-1 (Ø 3/16")	10 3/4	273	4 1/2	2.0	90	101
CP0214CELEL	Single	CR-1 (Ø 3/16")	10 5/16	262	4 1/2	2.0	90	101
CP0214ENBEL	Tandem	CR-1 (Ø 3/16")	11 5/16	303	4 3/4	2.2	90	101
CP0214ENFEL	Tandem	CR-1 (Ø 3/16")	12 3/4	324	5 1/4	2.4	90	101
CP0214ENGEL	Tandem	CR-1 (Ø 3/16")	13 1/2	343	5 1/2	2.5	90	101
CP0214FALEL	Tandem	CR-1 (Ø 3/16")	14	356	5 1/2	2.5	90	101
CP0214KETEL	Tandem	CR-2 (Ø 1/4")	14	356	5 1/2	2.5	90	101
CP0214SETEL	Single	CR-2 (Ø 1/4")	10 5/16	262	4 1/2	2.0	90	101
CP0341CUDEL	Pneumatic [®]	CR-1 (Ø 3/16")	19 7/8	505	13 1/2	6.1	85	-
CP0351ASGEL	Single	CR-1 (Ø 3/16")	19 1/2	495	15 3/4	7.1	96	107
CP0351ASKEL	Single	CR-1 (Ø 3/16")	21 5/8	549	19 3/4	9.0	96	107
CP0351ASVEL	Single	CR-1 (Ø 3/16")	25 3/4	654	26 1/4	11.9	96	106
CP0351CUDEL	Single	CR-1 (Ø 3/16")	17 1/2	445	12 1/2	5.7	96	107
CP0351ESGEL	Tandem	CR-1 (Ø 3/16")	23 3/4	603	18 1/2	8.4	96	107
CP0351ESKEL	Tandem	CR-1 (Ø 3/16")	25 7/8	657	22 1/2	10.2	96	107
CP0351ESREL	Tandem	CR-1 (Ø 3/16")	27 7/8	708	27	12.2	96	107
CP0351ESVEL	Tandem	CR-1 (Ø 3/16")	30	762	29	13.2	96	107
CP0351FUDEL	Tandem	CR-1 (Ø 3/16")	21 3/4	552	15 1/4	6.9	96	107
CP0351PU	Single	n/a	21 1/2	546	20 1/2	9.3	96	107
CP0351CABHDY	Single	n/a	17 1/2	445	20 5/16	9.2	96	107

Compression Tools – Rivet Sizes (Reference)

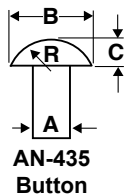

A		B		C		R	
in.	mm	in.	mm	in.	mm	in.	mm
AN-435 A.S.A. BUTTON							
3/32"	2.4	0.166	4.22	0.070	1.78	0.084	2.13
1/8"	3.2	0.219	5.56	0.094	2.39	0.111	2.82
5/32"	4.0	0.273	6.93	0.117	4.32	0.138	3.51
3/16"	4.8	0.328	8.33	0.141	3.58	0.166	4.22
1/4"	6.4	0.437	11.10	0.188	4.78	0.221	5.61
5/16"	7.9	0.546	13.87	0.234	5.94	0.276	7.01

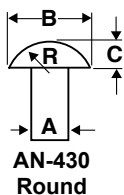

A		B		C		R	
in.	mm	in.	mm	in.	mm	in.	mm
AN-430 ROUND							
3/32"	2.4	0.187	4.75	0.070	1.78	0.098	2.49
1/8"	3.2	0.250	6.45	0.094	2.39	0.130	3.30
5/32"	4.0	0.312	7.92	0.117	2.97	0.162	4.11
3/16"	4.8	0.375	9.53	0.141	3.58	0.195	4.95
1/4"	6.4	0.500	12.70	0.188	4.78	0.260	6.60
5/16"	7.9	0.648	16.46	0.234	5.94	0.325	8.26

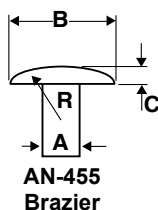

A		B		C		R	
in.	mm	in.	mm	in.	mm	in.	mm
AN-455 BRAZIER							
3/32"	2.4	0.234	5.94	0.047	1.19	0.170	4.32
1/8"	3.2	0.312	7.92	0.063	1.60	0.226	5.74
5/32"	4.0	0.390	9.90	0.078	1.98	0.283	7.19
3/16"	4.8	0.468	11.89	0.094	2.39	0.340	8.64
1/4"	6.4	0.625	15.83	0.125	3.18	0.453	11.51
5/16"	7.9	0.781	19.84	0.156	3.96	0.565	14.35

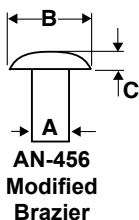

A		B		C	
in.	mm	in.	mm	in.	mm
AN-456 MODIFIED BRAZIER					
3/32"	2.4	0.156	3.96	0.031	7.90
1/8"	3.2	0.235	5.97	0.047	1.19
5/32"	4.0	0.312	7.92	0.063	1.60
3/16"	4.8	0.390	9.91	0.078	1.98
1/4"	6.4	0.468	11.89	0.094	2.39
5/16"	7.9	0.625	15.88	0.125	3.18

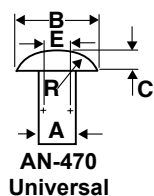

A		B		C		R		E	
in.	mm	in.	mm	in.	mm	in.	mm	in.	mm
AN-470 UNIVERSAL									
3/32"	2.4	0.187	4.75	0.041	1.04	0.082	2.08	0.047	1.19
1/8"	3.2	0.250	6.45	0.054	1.37	0.108	2.74	0.063	1.60
5/32"	4.0	0.312	7.92	0.067	1.70	0.135	3.43	0.078	1.98
3/16"	4.8	0.375	9.53	0.082	2.08	0.164	4.17	0.094	2.39
1/4"	6.4	0.500	12.70	0.107	2.72	0.217	5.51	0.125	3.18
5/16"	7.9	0.648	16.46	0.136	3.45	0.272	6.91	0.156	3.96

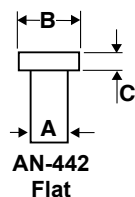

A		B		C	
in.	mm	in.	mm	in.	mm
AN-442 FLAT					
3/32"	2.4	0.187	4.75	0.037	0.94
1/8"	3.2	0.250	6.45	0.050	1.27
5/32"	4.0	0.312	7.92	0.062	1.57
3/16"	4.8	0.375	9.53	0.075	1.91
1/4"	6.4	0.500	12.70	0.100	2.54
5/16"	7.9	0.648	16.46	0.125	3.18

Accessories

D144-T.. / S144-T.. / D170-L / AV101 / CP9361..

ACCESSORIES INCLUDED

ITEM	Application	PART NUMBER				
		D144-T	S144-T	D170-L	AV101	CP9361 CP9361-1
• Air Hose – 3/16" bore						P043886 P043886
• Air Filter Assembly						P056381 P056381
• Stylus – carbide tipped						P054177 P054177
• Exhaust hose		222453		222453		
• Exhaust Hose Clip		235203		235203		
• Spindle Wrench		164433		15533		
• Clamp Nut Wrench		29443				
• Guard Nut Wrench		29653				
• Hex. Key – 4mm A/F		204903		204903		
1 Saw Blade – diamond coated (2.52" - 64mm dia.)	Fibreglass	32732				
1 Saw Blade – 80 teeth (1.77" - 45mm dia.)	Soft Steel <1.2mm		76362			
1 Saw Blade (3.15" - 80mm dia.)	Plastics			90762		
1 Saw Blade – teflon coated (3.15" - 80mm dia.)	Plastics			90772		
2 Saw Blade (2" radius x 1.97" wide - 50.8mm x 50mm)	Soft Wood			90832		
3 Depth Gauge				27262		
• Upholstery Nozzle					106443	
• Crevice Nozzle					106533	
• Anvils for use with chisels & blanks						P054207
• Flat Chisel	Scaling & Deburring					P054183
• Chisel Blank	customise to suit					P054184
• Round nose Chisel	Cleaning weld beads					P054182
• Carrying Case						P137979

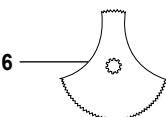
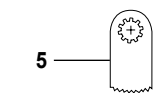
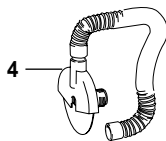
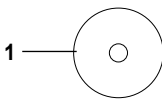
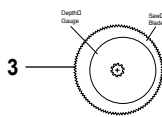
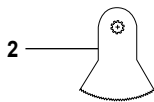
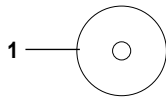

OPTIONAL ACCESSORIES

ITEM	Application	PART NUMBER		
		D144-T	S144-T	D170-L
1 Saw Blade (2.52" - 64mm dia.)	Wood	34252		
1 Saw Blade (1.97" - 50mm dia.)	Soft Steel >1.2mm (max depth 7mm)		76372	
1 Saw Blade (1.97" - 50mm dia.)	Hard Steel <1.2mm (max depth 10mm)		76382	
1 Saw Blade (1.97" - 50mm dia.)	Aluminium (max depth 10mm)		76392	
4 Dust Extraction Hood (includes 3m hose – 1.26" (32mm) ID)				78472
1 Saw Blade – diamond tipped (2.52" - 64mm dia.)	Fibreglass			16962
1 Saw Blade – diamond tipped 1.2mm tooth pitch (2.52" - 64mm dia.)	Fibreglass			90722
1 Saw Blade – diamond tipped 1.2mm tooth pitch (3" - 80mm dia.)	Fibreglass			90732
1 Saw Blade – 1.5mm tooth pitch (2.01" - 51mm dia.)	Soft Wood			90782
1 Saw Blade – 1.8mm tooth pitch (2.52" - 64mm dia.)	Soft Wood			90792
1 Saw Blade – 1.5mm tooth pitch (2.99" - 76mm dia.)	Soft Wood			90802
5 Saw Blade (0.87" radius x 0.59" wide - 22mm radius x 15mm wide)	Soft Wood			90822
6 Saw Blade (2.36" + 0.63" dia - 60mm + 16mm segments)	Soft Wood			90842

Miscellaneous Tools



A



B



C



D



E



F

Air Inlet: 1/4" BSP/NPT. D170 Vibration level: 8.7 m/s². CP9361 Vibration level: <2.7 m/s². Others Vibration level: <2.5 m/s².

PICTURE REF	MODEL	PART NUMBER	OSCILLATING FREQUENCY	FREE SPEED		LENGTH		AIR FLOW		MIN HOSE BORE		SOUND LEVEL	
				r/min	lb	kg	in.	mm	cfm	l/s	in.		mm
FIBREGLASS SAW – CAPACITY 1/2" (13mm) DEPTH													
A	D144-T-3300	1273234	–	3300	1.96	0.90	9.01	229	19.9	9.4	3/8	10	76
CIRCULAR SAW – CAPACITY 3/8" (10mm) DEPTH (hard steel 3/64" (1.2mm) depth)													
B	S144-T-3100	936974	–	3100	3.08	1.40	9.65	245	19.9	9.4	3/8	10	80
OSCILLATING SAW													
C	D170-L	1261574	19000	–	2.00	0.91	11.30	287	19.7	9.3	3/8	10	76
VACUUM CLEANER													
D	AV101	128534	–	–	1.54	0.70	7.95	202	12.5	5.9	1/4	6	90
AIR SCRIBE													
E	CP9361	T012644	–	–	0.31	0.14	5.00	127	1.1	0.5	3/16	5	79
AIR SCRIBE KIT													
F	CP9361-1	T011970	–	–	0.31	0.14	6.00	127	1.1	0.5	3/16	5	79