

Fixed electric tools

MC - MCL range

2 to 1 900 Nm (1.5 to 1400 ft.lb) - 30 to 1590 rpm



A



B

Lou Zampini & Associates

2 Douglas Pike, Rt. 7

Smithfield, RI 02917

1 800 353 4676

FAX 1 401 679 0165

* Tool rotation speeds are provided for a supply voltage of 230 Volts to the CVIC. For 115 Volts, these speeds are reduced by 15%.

PICTURE REF	MODEL	PART NUMBER	TORQUE RANGE		ROTATION SPEED*	SQUARE DRIVE	MIN DISTANCE BET. CENTRES	STROKE	WEIGHT	
			Nm	ft.lb					rpm	inch
A	MC35-10	615 165 107 0	2 - 8	1.5 - 5.9	1 590	3/8"	43.2	50	1.5	3.3
A	MC35-20	615 165 108 0	5 - 15	3.7 - 11.0	1 590	3/8"	43.2	50	1.5	3.3
A	MC38-10	615 165 109 0	10 - 30	7.4 - 22.0	990	3/8"	43.2	50	2.0	4.4
A	MC38-20	615 165 110 0	15 - 45	11.0 - 33.0	840	3/8"	43.2	50	2.0	4.4
A	MC51-10	615 165 111 0	25 - 70	18.0 - 52.0	500	1/2"	51.2	50	2.9	6.4
A	MC51-20	615 165 112 0	45 - 135	33.0 - 99.0	310	1/2"	51.2	50	3.2	7.0
A	MC60-10	615 165 113 0	30 - 95	22.0 - 70.0	710	1/2"	60.2	50	4.8	10.6
A	MC60-20	615 165 114 0	60 - 175	44.0 - 129.0	390	3/4"	60.2	50	4.8	10.6
A	MC60-30	615 165 115 0	80 - 250	59.0 - 184.0	230	3/4"	60.2	50	5.2	11.5
A	MC80-10	615 165 116 0	100 - 300	74.0 - 221.0	220	3/4"	80.2	60	9.8	21.6
A	MC80-20	615 165 117 0	150 - 450	110.0 - 332.0	150	3/4"	80.2	60	9.8	21.6
A	MC80-30	615 165 118 0	220 - 650	162.0 - 479.0	100	1"	80.2	60	9.8	21.6
A	MC80-40	615 165 119 0	270 - 800	199.0 - 589.0	70	1"	80.2	60	9.8	21.6
A	MC106-10	615 165 120 0	500 - 1500	368.0 - 1105.0	40	1"	106.2	60	15.0	33.0
A	MC106-20	615 165 121 0	600 - 1900	442.0 - 1400.0	30	1"	106.2	60	15.0	33.0
B	MCL38-20	615 165 124 0	15 - 45	11.0 - 33.0	840	3/8"	43.2	50	3.0	6.6
B	MCL51-20	615 165 125 0	45 - 135	33.0 - 99.0	310	1/2"	51.2	50	4.0	8.8
B	MCL60-20	615 165 126 0	60 - 175	44.0 - 130.0	370	3/4"	60.2	50	6.0	13.2
B	MCL60-30	615 165 127 0	80 - 250	59.0 - 184.0	240	3/4"	60.2	50	6.0	13.2
B	MCL80-40	615 165 128 0	270 - 800	199.0 - 590.0	70	1"	80.2	60	11.0	24.2

CVIC and MODCVIC

Controllers



TECHNICAL FEATURES

CVIC controller

Mains supply	Single-phase 100 to 250 Volts 50 / 60 hertz
Consumption (current)	CVIC-2 : 4 A (115 V) - 2 A (230 V) CVIC-4 : 8 A (115 V) - 4 A (230 V)
Weight	5 kg
Overall size	Width 260 mm / Height 270 mm / Depth 170 mm

PART NO.

CVIC controller

PART NO.

For ECD5 /	CVIC L-2	CVIC M-2	CVIC H-2
ECP5 / MC35-10	615 932 608 0	615 932 601 0	615 932 610 0
For	CVIC L-4	CVIC M-4	CVIC H-4
the other tools	615 932 609 0	615 932 603 0	615 932 611 0

MODCVIC module

Single-phase or three-phase 100 to 250 Volts 50 / 60 hertz
MODCVIC-2 : 4 A (115 V) - 2 A (230 V) MODCVIC-4 : 8 A (115 V) - 4 A (230 V)
4 kg
Width 100 mm / Height 320 mm / Depth 270 mm

MODCVIC module

PART NO.

For ECD5 / ECP5 / MC35-10	MODCVIC L-2	MODCVIC H-2
	615 932 612 0	615 932 602 0
For the other tools	MODCVIC L-4	MODCVIC H-4
	615 932 613 0	615 932 604 0

PACK controller (see detail on page 7)

PART NO.

PACKCVIC (supplied without MODCVIC)	615 932 607 0
-------------------------------------	----------------------

START-UP KIT to be ordered with the controller

Including: **Plug + Literature + Connector**

PLUG	LITERATURE	PART NO.
A	French	615 928 040 0
C	English	615 928 041 0
A	English	615 928 046 0
D	English	615 928 047 0
B	English	615 928 049 0
A	German	615 928 042 0
A	Spanish	615 928 043 0
E	Italian	615 928 044 0
A	Dutch	615 928 048 0
A	Swedish	615 928 045 0



OPTIONAL ACCESSORIES

	PART NO.
CVIS/CVICPC 2000 software	615 927 521 0
CVICPC NETWORK 2000 software	615 927 523 0
PC cable Length 2 m	615 917 047 0
Printer cable Length 2 m	615 917 011 0



A

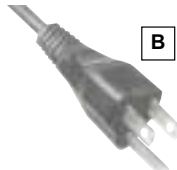

B



C



D



E

Technical features

CVIC and MODCVIC controllers

MAIN FUNCTIONS	VERSIONS		
	L	M	H
Access to tool parameters (tool memory)	✓	✓	✓
Maintenance aid	✓	✓	✓
Number of stored results	0	100	100

PERIPHERALS	L	M	H
PC point-to-point connection	✓	✓	✓
PC network connection		✓	✓
Bar code reader connection to select a cycle		✓	✓

TIGHTENING CYCLES AND STRATEGIES	L	M	H
Quick cycle with self-learning of the joint	✓	✓	✓
Number of cycles in the controller	0	7	7
Cycle in the tool	1	1	1
Number of phases	2	4	15
Counting of the number of cycles run "OK" (99)		✓	✓

TYPES OF PHASES IN A CYCLE	L	M	H
Search Sequence		✓	✓
Run Down	✓	✓	✓
Torque controlled final speed phase	✓	✓	✓
Angle-controlled final speed phase			✓
Angle-controlled run reverse			✓
Restart cycle in case of defect		✓	✓
Prevailing torque monitoring			✓

TIGHTENING STRATEGIES	L	M	H
Torque and angle monitoring	✓	✓	✓
Angle and torque monitoring			✓

MODEL PART NO.	L	M	H
CONTROLLER for ECD5 / ECP5 / MC35-10	CVIC L-2	CVIC M-2	CVIC H-2
MODULE for ECD5 / ECP5 / MC 35-10	MODCVIC L-2		MODCVIC H-2
CONTROLLER for the other tools	CVIC L-4	CVIC M-4	CVIC H-4
MODULE for the other tools	MODCVIC L-4		MODCVIC H-4

Example of order for 1 complete station of portable nutrunner

		PART NO.	
Tool	1	Portable angle nutrunner ECA60	615 165 103 0
	1	Cable length 10 m	615 917 214 0
Controller	1	CVIC M-4	615 932 603 0
	1	Start-up kit (U.K)	615 928 041 0



Portable Electric Nutrunners

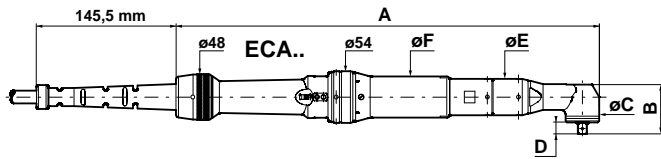

(mm)	ECA20	ECA30	ECA40	ECA60	ECA70	ECA90	ECA115	ECA125	ECA150	ECA200
A	431	431	441	453	538	538	538	541	541	591
B	45,5	45,5	51,5	57,5	66	66	66	69	69	86
C	28	28	35	40	45	45	45	50	50	60
D	12	12	12	12	16,5	16,5	16,5	16,5	16,5	25
E	38	38	38	38	51	51	51	51	51	51
F	43	43	43	43	51	51	51	51	51	51

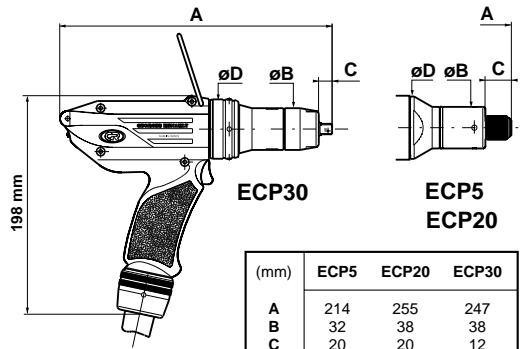

(mm)	ECP5	ECP20	ECP30
A	214	255	247
B	32	38	38
C	20	20	12
D	48	54	54

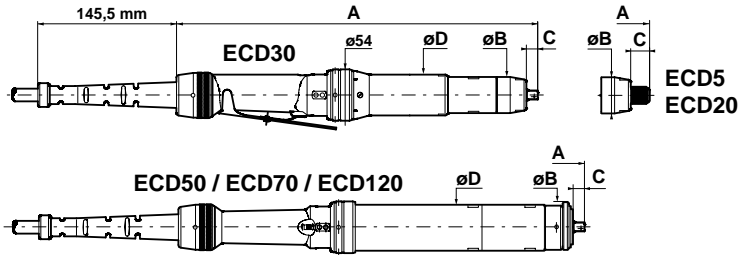

(mm)	ECD5	ECD20	ECD30	ECD50	ECD70	ECD120
A	346	388	380	456	461	488
B	32	38	38	54	54	54
C	20	20	12	12	16,5	16,5
D	43	43	43	51	51	51

OPTIONAL ACCESSORIES

	PART NO.		PART NO.
Cable length 5 m	615 917 212 0	Extension cable length 5 m	615 917 222 0
Cable length 10 m	615 917 214 0	Extension cable length 10 m	615 917 224 0
Cable length 15 m	615 917 215 0	Extension cable length 15 m	615 917 225 0
		Extension cable length 20 m	615 917 226 0
		Extension cable length 25 m	615 917 227 0
		Extension cable length 30 m	615 917 228 0

SUSPENSION BAIL

	FIXED	LING SWIVEL
For ECD5/20/30 - ECA20/30/40/60	615 571 056 0	615 396 228 0
For ECD50/70/120 - ECA70/90/115/125/150/200	615 571 050 0	615 396 229 0

REACTION BAR RING

	ECA60	ECA70/90/115/125/150	ECA200
	615 396 226 0	615 396 227 0	615 396 230 0

HANDLE LEVER

	PART NO.
Included in standard features on ECD5	615 321 189 0

BALANCERS

CAPACITY	CABLE LENGTH	WEIGHT	PART NO.
Min Max	m	kg	
1.4 - 2.4 kg	1.5	0.6	50542
2.0 - 5.0 kg	2.4	2.7	50052
5.0 - 7.0 kg	2.4	3.2	50062

INDICATOR BOX

	PART NO.
LED-type indicator box to display the reports	615 936 001 0

SOCKET TRAY

	PART NO.
Socket tray (sockets are not supplied)	615 936 005 0
Cable for SOCKET TRAY : Length 1 m	615 917 241 0
Length 5 m	615 917 242 0
Length 10 m	615 917 244 0
Length 15 m	615 917 245 0

GEARED OFFSET HEADS (Crowfoot)

(Please ask our department)



Portable Electric Nutrunners

EC range

2 to 200 Nm (1.5 to 147 ft.lb) - 170 to 1590 rpm



A



B



C



Sound level lower than 70 dBA as per EN 50144-1
Vibration level lower than 2.5 m/s² as per EN 50144-2-2

TOOLS TO BE USED WITH ARTICULATED ARMS: From 20 Nm upwards, the portable electric power tools of the ECD range are supplied with a reaction bar ring.

PICTURE REF	MODEL	PART NUMBER	TORQUE RANGE		ROTATION SPEED	SQUARE DRIVE	LENGTH	WEIGHT		MIN.CENTRE/EDGE DIST
			Nm	ft.lb				kg	lb.	
ANGLE HEAD										
A	ECA20	615 165 100 0	7 - 20	5.2 - 15	1140	3/8	431	1.7	3.7	14.0
A	ECA30	615 165 101 0	10 - 30	7.4 - 22	880	3/8	431	1.7	3.7	14.0
A	ECA40	615 165 102 0	13 - 40	9.6 - 29	690	3/8	441	1.8	4.0	17.5
A	ECA60	615 165 103 0	20 - 60	15.0 - 44	440	3/8	453	1.9	4.2	20.0
A	ECA70	615 165 104 0	23 - 70	17.0 - 52	530	1/2	538	3.3	7.3	22.5
A	ECA90	615 165 105 0	30 - 90	22.0 - 66	420	1/2	538	3.3	7.3	22.5
A	ECA115	615 165 106 0	39 - 115	29.0 - 85	290	1/2	538	3.3	7.3	22.5
A	ECA125	615 165 188 0	40 - 125	29.5 - 92	280	1/2	541	3.6	7.9	22.5
A	ECA150	615 165 189 0	50 - 150	37.0 - 11	230	1/2	541	3.6	7.9	22.5
A	ECA200*	615 165 190 0	70 - 200	51.6 - 147	170	3/4	591	3.8	8.4	30.0
IN-LINE										
B	ECD5	615 165 068 0	2 - 6	1.5 - 4.4	1590	HEX 1/4	346	1.1	2.4	16.0
B	ECD20	615 165 093 0	7 - 20	5.2 - 15.0	1200	HEX 1/4	388	1.5	3.3	19.0
B	ECD30	615 165 094 0	10 - 30	7.4 - 22.0	850	3/8	380	1.5	3.3	19.0
B	ECD50	615 165 095 0	16 - 50	12.0 - 37.0	790	3/8	456	2.6	5.7	27.0
B	ECD70	615 165 096 0	23 - 70	17.0 - 52.0	500	1/2	461	2.6	5.7	27.0
B	ECD120	615 165 097 0	40 - 120	29.4 - 88.0	310	1/2	488	3.1	6.8	27.0
PISTOL GRIP										
C	ECP5	615 165 069 0	2 - 8	1.5 - 5.9	1590	HEX 1/4	214	1.1	2.4	16.0
C	ECP20	615 165 098 0	7 - 20	5.2 - 15.0	1200	HEX 1/4	255	1.5	3.3	19.0
C	ECP30	615 165 099 0	10 - 30	7.4 - 22.0	850	3/8	247	1.5	3.3	19.0

* Available at end of 2000

Fixed electric tools

For further information, please ask for our data sheet

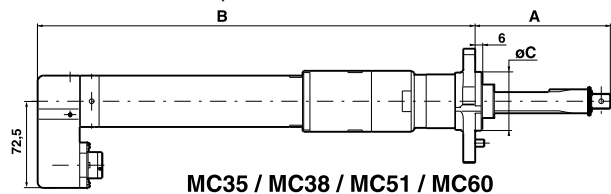

MC35 / MC38 / MC51 / MC60

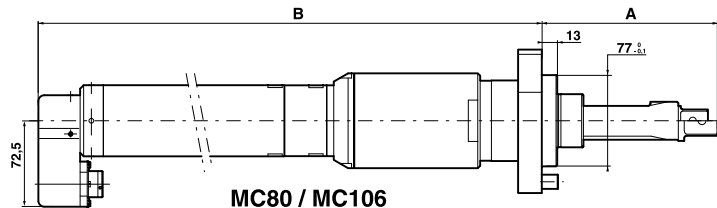

MC80 / MC106

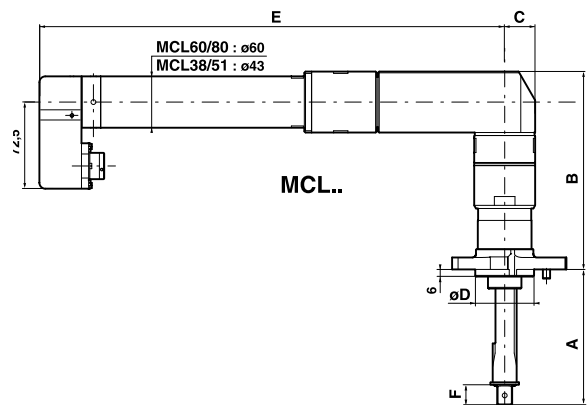

MCL..

(mm)	MC35-10	MC35-20	MC38-10	MC38-20	MC51-10	MC51-20	MC60-10	MC60-20	MC60-30
A	87	87	87	87	113	113	113	113	121,5
B	276	301	347	347	366	393	417	417	453
C	35	35	35	35	49,2	49,2	49,2	49,2	49,2

(mm)	MC80-10	MC80-20	MC80-30	MC80-40	MC106-10	MC106-20
A	140	140	148	148	148	148
B	480	480	480	480	556	556

(mm)	MCL38-20	MCL51-20	MCL60-20	MCL60-30	MCL80-40
A	87	112	121	121	148
B	140,5	166	178	178	240
C	19	25,5	25,5	25,5	25,5
D	35	49,2	49,2	49,2	77
E	351	389	423	423	423
F	11	15,5	23	23	28

OPTIONAL ACCESSORIES

		PART NO.
Cable	Length 5 m	615 917 232 0
Cable	Length 10 m	615 917 234 0
Cable	Length 15 m	615 917 235 0
Cable	Length 20 m	615 917 236 0
Cable	Length 25 m	615 917 237 0
Cable	Length 30 m	615 917 238 0
Extension cable	Length 5 m	615 917 222 0
Extension cable	Length 10 m	615 917 224 0
Extension cable	Length 15 m	615 917 225 0
Extension cable	Length 20 m	615 917 226 0
Extension cable	Length 25 m	615 917 227 0
Extension cable	Length 30 m	615 917 228 0



INDICATOR BOX

	PART NO.
LED-type indicator box to display the reports	615 936 001 0