

Série C
06/2002KA313EC4 – KA320-7 – KA312-7 – KA312E7 – KA320E7
KA309-9 – KA320-9 – KA312-9 – KA320E9 – KA312E9MEULEUSES D'ANGLE
WINKELSCHLEIFMASCHINE
KULMAHIOMAKONE
VINKELSLIBEMASKINEANGLE GRINDERS
MOLATRICE AD ANGOLO
SLIPMASKIN VINKELMODELL
HAAKSE SLIJPMACHINEAMOLADORAS ANGULARES
ESMERILADORA ANGULAR
VINKELSLIPEMASKIN
ΓΩΝΙΑΚΟΣ ΛΕΙΑΝΘΡΑΣ

Série C

	Attention - Warning - Cuidado - Achtung - Attenzione Atenção - Opgelet - Huomio - Obs! - Advarsel – Advarsel - Προσοχή	
F	Avant toute utilisation ou intervention sur l'outil, veuillez à ce que les informations suivantes ainsi que les instructions fournies dans le guide de sécurité (Code article : 6159947180) aient été lues, comprises et respectées. Les caractéristiques et descriptifs de nos produits sont susceptibles d'évolution sans préavis de notre part.	Page 6 Page 18
EN	To reduce the risk of injury, before using or servicing tool, read and understand the following information as well as separately provided safety instructions (Item number: 6159947180). The features and descriptions of our products are subject to change without prior notice.	Page 7 Page 18
ES	Antes de utilizar la herramienta o intervenir sobre ella, asegúrese de que la información que figura a continuación, así como las instrucciones que aparecen en la guía de seguridad (Código artículo: 6159947180) han sido leídas, entendidas y respetadas. Las características y descripción de nuestros productos son susceptibles de evolución sin previo aviso por parte nuestra.	Página 8 Página 18
D	Werkzeuge erst benutzen, wenn die nachstehenden Hinweise und die Regeln des Sicherheitsleitfaden (Artikel-Nr. 6159947180) gelesen und verstanden wurden. Die Eigenschaften und Beschreibungen unserer Produkte sind der Weiterentwicklung unterworfen und bedürfen keiner vorherigen Benachrichtigung unsererseits.	Seite 9 Seite 18
I	Prima di qualsiasi utilizzazione o intervento sull'attrezzo, verificate che le informazioni che seguono e le istruzioni contenute nella guida di sicurezza (Codice articolo: 6159947180) siano state lette, comprese e rispettate. Le caratteristiche e le descrizioni dei nostri prodotti sono soggette a cambiamenti senza preavviso da parte nostra.	Pagina 10 Pagina 18
P	Antes de utilizar ou intervir na ferramenta, leia atentamente e respeite as informações seguintes assim como as instruções fornecidas no manual de segurança (Código artigo: 6159947180). As características e descrições dos nossos produtos estão sujeitas a evoluções sem aviso prévio.	Pág. 11 Pág. 18
FIN	Lue huolellisesti seuraavat ohjeet samoin kuin turvallisuusohjeet (Tuotekoodi : 6159947180) ennen työkalun käyttöönottoa. Tämän laitteen ominaisuudet ja selostus voivat muuttua ilman erillistä huomautusta.	Sivu 12 Sivu 18
S	Läs noga igenom dessa säkerhetsinstruktioner liksom anvisningarna i säkerhetsguiden (Artikelkod: 6159947180) innan du börjar använda verktyget. Egenskaperna hos och beskrivningen av våra produkter kan undergå förändringar utan föregående meddelande från vår sida.	Sida 13 Sida 18
N	Før enhver bruk eller reparasjon av verktøyet skal de følgende instruksjonene og forskriftene i sikkerhetsheftet (artikkelnummer: 6159947180) leses nøye. Spesifikasjonene og beskrivelsene av våre produkter kan endres uten av vi informerer spesielt om dette .	Side 14 Side 18
DK	Læs omhyggeligt, forstå og overhold disse instruktioner samt sikkerhedsforskrifterne (Varenummer: 6159947180), inden værktøjet tages i brug eller repareres. Vi forbeholder os ret til uden varsel at ændre egenskaberne for og beskrivelserne af vore produkter.	Side 15 Side 18
NL	Voor gebruik of demontage van het gereedschap altijd eerst zekerstellen dat de navolgende informatie evenals de geleverde veiligheidsinstructies (Code artikel: 6159947180) gelezen, begrepen en in acht genomen zijn. De eigenschappen en omschrijvingen van onze producten kunnen zonder voorafgaande kennisgeving onzerzijds ontwikkelingen ondergaan.	Blz 16 Blz 18
GR	Πριν από οποιαδήποτε χρήση ή επέμβαση στο εργαλείο, διαβάστε προσεκτικά, κατανοήστε και τηρήστε τις παρακάτω πληροφορίες, καθώς και τις οδηγίες που περιλαμβάνονται στο εγχειρίδιο ασφαλείας (Κωδικός προϊόντος: 6159947180). Τα χαρακτηριστικά και οι περιγραφές των προϊόντων μας μπορούν να τροποποιούνται χωρίς προηγούμενη ειδοποίηση.	Σελίδα 17 Σελίδα 18

Série B
2 / 20

KA313EC4 – KA320-7 – KA312-7 – KA312E7 – KA320E7
KA309-9 – KA320-9 – KA312-9 – KA320E9 – KA312E9

	KA309	KA312	KA313	KA318	KA320
tr/min	9 500	12 000	13 000	18 000	20 000
W (hp)	375 (0.5)	375 (0.5)	375 (0.5)	375 (0.5)	375 (0.5)

⊕ "Loctite 222 frein filet"
● "Loctite 243 frein filet"

⊕ 13 / 18	*	1,4 N.m
⊕ 31 / 18	↘	10 N.m
⊕ 31 / 24	↘	10 N.m
⊕ 22 / 18	↘	8 N.m
⊕ 22 / 24	↘	8 N.m
⊕ 25 / 11	↘	35 N.m
⊕ 28 / 11	↘	35 N.m
⊕ 28 / 25	↘	35 N.m
⊕ 35 / 30	↘	35 N.m
⊕ 1 / 11	↘	25 N.m
● 32 / 34-41-42	↘	5 N.m

*	
Sens de serrage	Kiristyssuunta
Tightening direction	Åtdragningsriktning
Sentido de apriete	Tilstrammingsretning
Anziehrichtung	Tilspændingsretning
Senso di serraggio	Schroefrichting
Sentido de aperto	Φορά σύσφιξης

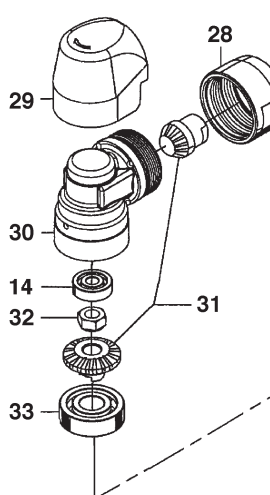
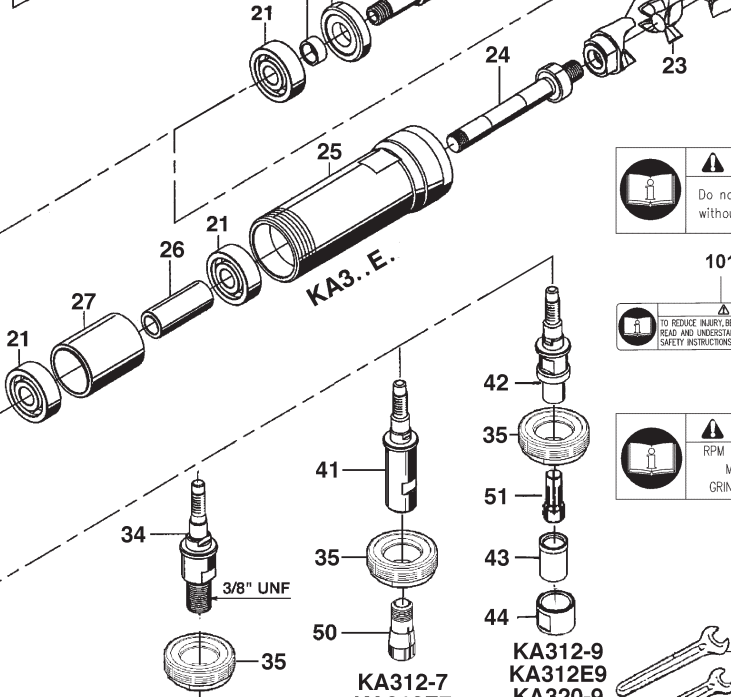
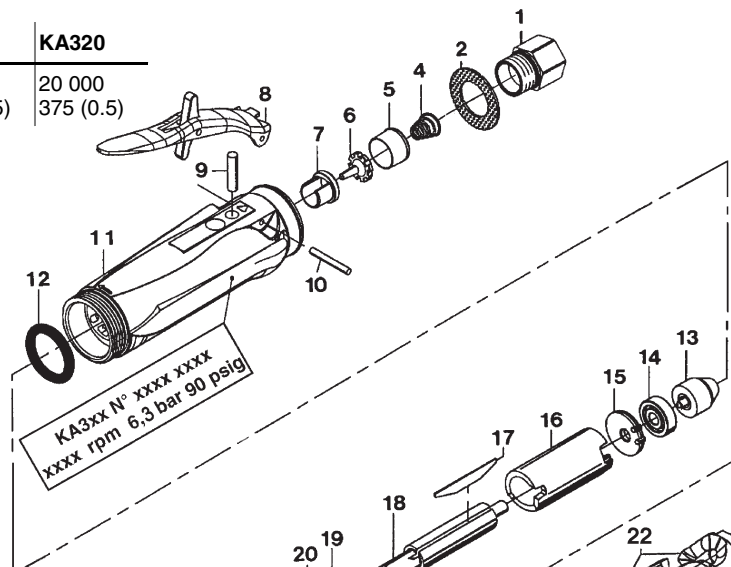

100 **WARNING**
Do not operate without wheel Guard 6158726940

101 **WARNING**
TO REDUCE INJURY, BEFORE USING OR SERVICING TOOL, READ AND UNDERSTAND SEPARATELY PROVIDED SAFETY INSTRUCTIONS. 6158726940

102 **WARNING**
RPM RATING ON WHEEL MUST EXCEED GRINDER RPM RATING 6158726900

H	mm
H Maxi	6,6
H mini	5,8

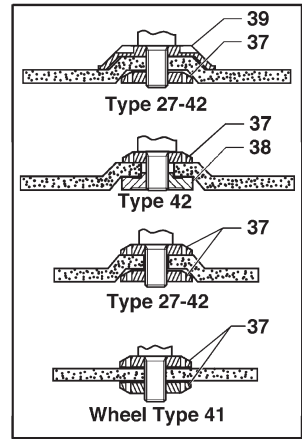
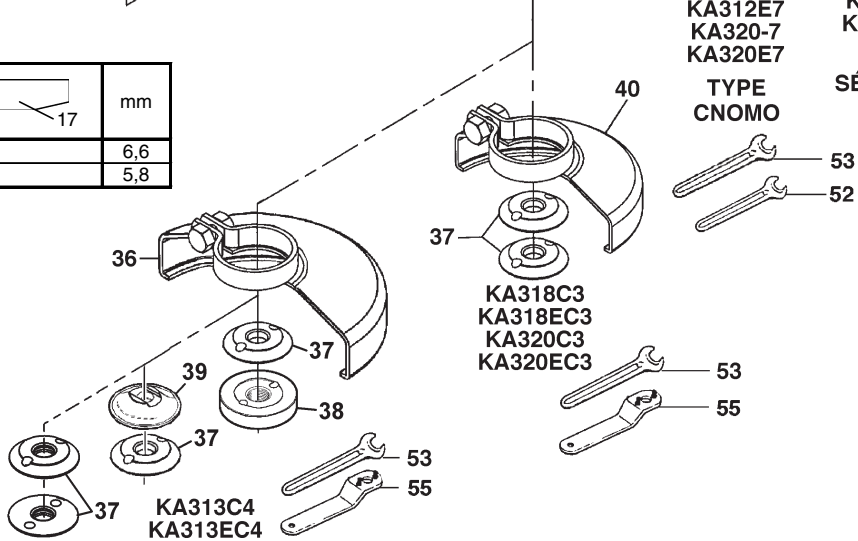

KA313EC4 – KA320-7 – KA312-7 – KA312E7 – KA320E7
KA309-9 – KA320-9 – KA312-9 – KA320E9 – KA312E9

Série B

3 / 20

Nomenclature des pièces

Teileliste

Osien nimikkeistö

Delfortegnelse

Parts list

Lista dei pezzi

Stycklista

Naamlijst van onderdelen

Lista de componentes

Nomenclatura das peças

Delliste

Κατάλογος εξαρτημάτων

Rep. Item	Ref. standard New part N°	Ref. CP Old CP part N°	Qté Qty	Pièces spécifiques Specific parts	Désignation	Description
1	746.62	C149822	1		Raccord d'adm. 1/4	Adapter complete
2	574.44	C149808	1		Silencieux	Silencer
4	681.89	C149820	1		Ressort de clapet	Spring valve
5	430.22	C149795	1		Tube d'admission	Tube inlet
6	155.10	C149787	1		Clapet d'admission	Throttle valve
7	321.168	C149789	1		Siège du clapet	Seat valve
8	321.165	C149788	1		Levier de sécurité	Throttle lever
9	790.34	C149827	1		Aiguille	Pin
10	790.99	C149828	1		Aiguille	Pin
11	566.458	C149845	1		Carter turbine	Motor housing
12	658.263	C149815	1		Joint torique	O ring
13	615 457045 0	-	1	KA309-9	Régulateur 18K	Governor 18K
13	457.25	C149841	1	KA313..	Régulateur 25K	Governor 25K
13	457.29	C149798	1	KA312..	Régulateur 23K	Governor 31K
13	457.31	C149879	1	KA318..	Régulateur 33K	Governor 40K
13	457.30	C149799	1	KA320...	Régulateur 37K	Governor 20K
14	758.63	C149826	2		Roulement	Ball bearing
15	422.146	C149793	1		Joue AR	Rear end plate
16	400.134	C149791	1		Cylindre	Cylinder
17	434.55	C149796	3		Palette	Blade
18	426.92	C149794	1		Rotor	Rotor
19	420.134	C149792	1		Joue AV	Front end plate
20	660.56	C149816	1		Bague de joue	Collar rotor
21	758.113	C149823	2	KA3..E	Roulement	Ball bearing
21	758.113	C149823	1	KA3..	Roulement	Ball bearing
22	575.104	C149809	2		Fourche d'accouplement	Fork coupling
23	575.105	C149810	1		Croix d'accouplement	Cross coupling
24	501.77	C149800	1		Arbre porte pince	Spindle extension
25	578.54	C149811	1		Carter rallonge	Housing extension
26	666.160	C149817	1		Entretoise	Spacer
27	666.161	C149818	1		Entretoise	Spacer
28	730.179	C149821	1		Bague d'orientation	Sleeve alignment
29	570.390	C149807	1		Gaine de protection	Sleeve protection
30	595.230	C149812	1		Carter d'angle	Housing angle
31	396.061	C149790	1		Couple conique	Gear-bevel
32	615 605089 0	-	1		Ecrou	Nut
33	758.117	C149825	1		Roulement	Ball bearing
34	615 501106 0	-	1		Arbre porte meule 3/8"	Spindle-wheel 3/8"
35	672.143	C149819	1		Bouchon du carter	Cap-angle housing
36	615 504160 0	-	1		Protecteur Ø 100	Guard 4"
37	615 502064 0	C149804	1	KA313C4 / KA313EC4	Flasque	Flange
37	615 502064 0	C149804	2	KA318.. / KA320C3 / KA320EC3	Flasque	Flange
38	615 606515 0	C138512	1		Flasque AR	Rear flange
39	615 503144 0	C150050	1		Flasque AR	Rear flange
40	615 504155 0	C149805	1		Protecteur Ø 80	Wheel guard 3"
41	615 501104 0	-	1		Arbre porte pince CNOMO	CNOMO collet holder
42	615 501107 0	-	1		Arbre porte pince série 300	Serie 300 collet holder
43	225.45	C149878	1		Entretoise	Washer
44	607.143	C149848	1		Ecrou de pince	Nut
101	615 872684 0	-	1		Etiquette protecteur	Warning guard label
102	615 872611 0	-	1		Etiquette instructions	Warning instruction
103	615 872690 0	-	1		Etiquette vitesse meuleuse	Warning wheel speed label

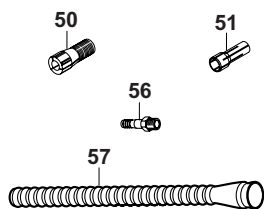
Série B
4 / 20KA313EC4 – KA320-7 – KA312-7 – KA312E7 – KA320E7
KA309-9 – KA320-9 – KA312-9 – KA320E9 – KA312E9Accessoires livrés
Mitgeliefertes Zubehör
Varusteet
Leveret tilbehørAccessories included
Accessori forniti
Levererade tillbehör
Geleverde accessoiresAccesorios suministrados
Acessórios fornecidos
Tilbehør som følger med
Παρεχόμενα εξαρτήματα

Rep. Item	Réf. standard New part N°	Réf. CP Old CP parts N°	Qté Qty	Désignation	Description
50	615 526046 0	-	1	Pince CNOMO Ø 6mm	Collet Ø 6mm
51	615 526059 0	C149838	1	Pince élastique série 300 Ø5,55 à 6,35mm	Serie 300 resilient collet Ø1/4"
52	615 801002 0	-	1	Clé plate de 10mm	Flat wrench 3/8"
53	615 801003 0	C149833	1	Clé plate de 11mm	Flat wrench 7/16"
54	615 801032 0	C149832	1	Clé plate de 17mm	Flat wrench 11/16"
55	615 802008 0	-	1	Clé à ergots de 20-3mm	Pin wrench
56	615 704019 0	-	1	Busette 1/4" pour tuyau Ø int. 8mm	Air hose nipple 1/4" for 5/16" ID hose
57	615 875106 0	-	1	Gaine d'échappement L=0,8m	Exhaust hose L=31"

KA313EC4 – KA320-7 – KA312-7 – KA312E7 – KA320E7
KA309-9 – KA320-9 – KA312-9 – KA320E9 – KA312E9

Série B
5 / 20

Accessoires en option
Optionales Zubehör
Lisävarusteet
Ekstra tilbehør

Optional accessories
Accessori in opzione
Tillbehör som tillval
Optionele accessoires

Accesorios opcionales
Acessórios em opção
Tilbehør som ekstratstyr
Προαιρετικά εξαρτήματα

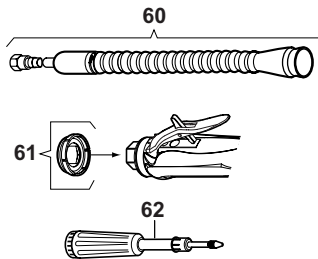

Rep. Item	Réf. standard New part N°	Réf. CP Old CP parts N°	Qté Qty	Désignation	Description
60	615 396101 0	C149880	1	Kit silencieux	Silencer kit
61	615 396124 0	C149928	1	Silencieux clipsable	Clipsable silencer
62	615 990149 0	C150332	1	Pompe à graisse (24 gr)	Grease gun 0.8 oz (24gr)
	615 990148 0	C150051	1	Graisse pour couple conique (1kg)	Grease for bevel gear 2.2lb (1kg)

KA3..-7 – KA3..E7



Rep. Item	Réf. standard New part N°	Réf. CP Old CP parts N°	Qté Qty	Désignation	Description
50	615 526089 0	-	1	Pince CNOMO Ø 2,5mm	CNOMO collet Ø 2,5mm
50	615 526044 0	-	1	Pince CNOMO Ø 3mm	CNOMO collet Ø 3mm
50	615 526045 0	-	1	Pince CNOMO Ø 3,2mm	CNOMO collet Ø1/8"
50	615 526090 0	-	1	Pince CNOMO Ø 4mm	CNOMO collet Ø5/32"
50	615 526091 0	-	1	Pince CNOMO Ø 4,5mm	CNOMO collet Ø 4,5mm
50	615 526092 0	-	1	Pince CNOMO Ø 5mm	CNOMO collet Ø 5mm
50	615 526047 0	-	1	Pince CNOMO Ø 6,4mm	CNOMO collet Ø1/4"

KA3..-9 – KA3..E9



Rep. Item	Réf. standard New part N°	Réf. CP Old CP parts N°	Qté Qty	Désignation	Description
51	615 526052 0	-	1	Pince élastique série 300 Ø 0,4 à 1,2mm	Serie 300 resilient collet Ø3/64" (0,4 to 1,2mm)
51	615 526053 0	-	1	Pince élastique série 300 Ø 1,2 à 2mm	Serie 300 resilient collet Ø5/64" (1,2 to 2mm)
51	615 526054 0	-	1	Pince élastique série 300 Ø 1,7 à 2,5mm	Serie 300 resilient collet Ø3/32" (1,7 to 2,5mm)
51	615 526055 0	C149837	1	Pince élastique série 300 Ø 2,4 à 3,2mm	Serie 300 resilient collet Ø1/8" (2,4 to 3,2mm)
51	615 526056 0	-	1	Pince élastique série 300 Ø 3,16 à 3,96mm	Serie 300 resilient collet Ø5/32" (3,16 to 3,96mm)
51	615 526057 0	-	1	Pince élastique série 300 Ø 3,95 à 4,75mm	Serie 300 resilient collet Ø3/16" (3,95 to 4,75mm)
51	615 526058 0	-	1	Pince élastique série 300 Ø 4,75 à 5,55mm	Serie 300 resilient collet Ø7/32" (4,75 to 5,55mm)

KA313EC4 – KA320-7 – KA312-7 – KA312E7 – KA320E7
KA309-9 – KA320-9 – KA312-9 – KA320E9 – KA312E9

Série B
7 / 20

INSTRUCTIONS

EN



This product is designed for removing material using abrasives. No other use permitted. For professional use only.

Before using or servicing the power tool, the supply of compressed air must be disconnected or shut off.



When disposing of components, lubricants, etc ... ensure that the relevant safety procedures are carried out.



The tool is designed for a working pressure of 6.3 bar (90 psig). The compressed air must be clean. The installation of a filter is recommended. For maximum efficiency and performance, comply with the specification of the air hose. Drain the air hose before connecting the tool. (Refer to figure no.1 for compressed air connection)

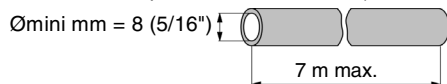

To obtain maximum efficiency from the pneumatic tool, preserve its features and avoid repeated repairs, a routine inspection and repair programme are recommended at least every 500 operating hours or every 6 months as a minimum. In heavy-duty conditions, the inspection program can be performed every 3 months.



- Disassemble the tool, clean and check the parts carefully.
- Check the condition of the bearings and inspect the vanes for wear and surface condition.



For dust extraction, please contact your local sales.



Check the free speed of the tool at regular intervals and after each operation or maintenance task. Remove the abrasive to check the speed. The maximum allowed speed shown on the tool must not be exceeded and the vibration level must not be excessive.



This tool is fitted with vanes which can operate without lubricated air. However, a small amount of oil allows the tool to provide full power and lengthens its life.

The use of dry air with no trace of oil may reduce the life of vanes.

Lubricating the bevel gear. Amount of grease: 1 gramme. Recommended grease: 615 990148 0 (Qty: 1Kg). The use of any other lubricant, in any other amount, will shorten the life and impair the operation of angle pinions.



© Copyright 2002, GEORGES RENAULT SA, 44230 France
All rights reserved. Any unauthorized use or copying of the contents or part thereof is prohibited. This applies in particular to trademarks, model denominations, part numbers and drawings. Use only authorized parts. Any damage or malfunction caused by the use of unauthorized parts is not covered by Warranty or Product Liability.

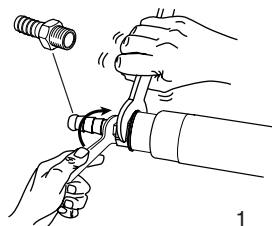

1

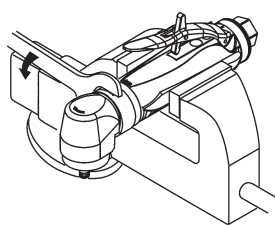

2

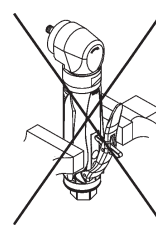

3

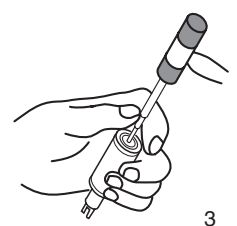

DISASSEMBLY AND REASSEMBLY INSTRUCTIONS



Disconnect the machine from the compressed air supply.
Remove all accessories.

Disassembling the Turbine (see figure 2):

Hold the housing (11) in one hand and extract the turbine assembly by pulling the pinion (31) or the coupling fork (22).

Position a flat wrench on the flats of the pinion (31) or of the coupling fork (22), then unscrew the governor (13).



Do not dismantle the governor, as it is an integral assembly.

Disassemble the turbine (see figure 3).

CLAMP THE ROTOR SLIGHTLY IN A VICE FITTED WITH LEAD JAWS, then unscrew the pinion (31) or the coupling fork (22).

Using a mallet, tap on the rotor (18) ends to extract the ball bearings (14-21).

Reassembling the Turbine :

Proceed in reverse order with respect to disassembly.



Be careful with the direction for assembling the vanes.

Apply a small quantity of "Loctite 222" on the thread of the governor (13) before tightening it to a 1.4 N.m. torque.

Be careful with the direction for assembling the cylinder, align the lugs of the rear end plate (15) with the cylinder (16) throttle.

KA3..E.. : Disassembling the extension housing.

To pull out the shaft assembly from the extension housing (25), tap with a mallet on the end of the coupling fork (22). Proceed in reverse order for reassembling.

Assembling the complete output shaft:



Be careful with the direction the nut (32) is fitted, with the cylindrical mark on gear side.

Apply a small quantity of "Loctite 243" on the nut (32) thread and tighten the nut on the shaft (34, 41 or 42) to a torque of 5 N.m.. Before reassembling the complete output shaft in the angle housing (30), lubricate the gear (Amount of grease: 1 gramme).

Série B

18 / 20

KA313EC4 – KA320-7 – KA312-7 – KA312E7 – KA320E7
KA309-9 – KA320-9 – KA312-9 – KA320E9 – KA312E9**F NIVEAU DE BRUIT ET EMISSION DE VIBRATIONS DECLARES :**

Ces valeurs sont mesurées par un laboratoire d'essais conformément aux normes en vigueur, en aucun cas elles ne peuvent être utilisées pour l'évaluation des risques. Les valeurs mesurées en travail peuvent être plus élevées que les valeurs déclarées. Les valeurs réelles d'exposition et les dommages physiques résultant de l'exposition aux vibrations sont spécifiques et dépendent de la façon dont l'utilisateur travaille, de la pièce travaillée et de sa forme, ainsi que du temps d'exposition et des capacités physiques de l'utilisateur. La Société, **GEORGES RENAULT**, ne peut être tenue pour responsable des dommages causés par des niveaux réels plus élevés que les niveaux déclarés, n'ayant elle-même aucun contrôle sur l'utilisation des machines.

EN DECLARATION OF NOISE AND VIBRATION EMISSION:

These declared values were obtained by laboratory type testing in compliance with the stated standards and are not adequate for use in risk assessments. Values measured in individual work places may be higher than the declared values. The actual exposure values and risk of harm experienced by an individual user are unique and depend upon the way the user works, the workpiece and the workstation design, as well as upon the exposure time and the physical condition of the user. We, **GEORGES RENAULT**, cannot be held liable for the consequences of using the declared values, instead of values reflecting the actual exposure, in an individual risk assessment in a work place situation over which we have no control.

ES DECLARACION DE EMISION DE RUIDOS Y VIBRACIONES :

Los datos que se declaran se obtuvieron en pruebas de laboratorio de acuerdo con los estándares indicados. No son apropiados para ser utilizados en la evaluación de riesgos. Los valores que se midan en puestos de trabajo individuales pueden ser superiores a los declarados. Los datos reales de exposición y el riesgo de daños que puede sufrir un operario concreto son únicos y dependen de la manera en que el operario trabaja, del diseño de la pieza trabajada y del puesto, así como del tiempo de exposición y las capacidades físicas del operario. La sociedad, **GEORGES RENAULT**, no podrá ser considerada responsable de los daños ocasionados por niveles reales superiores a los declarados, dado que no tiene control alguno sobre la utilización de las máquinas.

D GERÄUSCH- UND VIBRATIONSANGABEN:

Diese Werte wurden von einem Labor durch Typprüfungen gemäß den geltenden Normen ermittelt. Auf keinen Fall können sie zur Risikoabschätzung herangezogen werden. Werte in der individuellen Arbeitsumgebung können höher sein als die angegebenen Werte. Die tatsächlichen Werte und die gesundheitlichen Schäden, die durch die Belastung entstehen können, sind arbeitsplatzbezogen. Sie hängen von der Arbeitsweise des Bedieners, von der Beschaffenheit des bearbeiteten Werkstücks sowie von der Dauer der Belastung und den körperlichen Kapazitäten des Bedieners ab. Die Firma **GEORGES RENAULT** haftet nicht für Schäden, die durch höhere Emissionswerte als die angegebenen entstehen, da sie die Anwendung der Maschinen nicht unter Kontrolle hat.

I LIVELLO DI RUMOROSITÀ ED ÉMISSIONE DI VIBRAZIONI DICHIARATI:

Questi valori, misurati da un laboratorio di collaudo conformemente alle normative vigenti, non possono in nessun caso essere utilizzati per valutare i rischi. I valori misurati durante il lavoro possono essere più elevati dei valori dichiarati. I valori reali di esposizione e i danni fisici che risultano dall'esposizione alle vibrazioni sono specifici e dipendono dal modo di lavoro dell'utente, dal pezzo lavorato e dalla sua forma, ma anche dal tempo di esposizione e dalle capacità fisiche dell'operatore. La Società, **GEORGES RENAULT**, non può essere tenuta per responsabile dei danni causati da livelli reali più elevati rispetto ai livelli dichiarati, non avendo lei stessa nessun controllo sull'utilizzazione delle macchine.

P NÍVEL SONORO E EMISSÃO DE VIBRAÇÕES DECLARADOS:

Estes valores são medidos por um laboratório de ensaios em conformidade com as normas em vigor, não podem em caso algum ser utilizados para a avaliação dos riscos. Os valores medidos em trabalho podem ser mais elevados que os declarados. Os valores reais de exposição e os danos físicos resultantes da exposição às vibrações são específicos e dependem do modo como o utilizador trabalha, da peça trabalhada e de sua forma, assim como do tempo de exposição e das capacidades físicas do utilizador. A Sociedade **GEORGES RENAULT** não pode ser considerada como responsável pelos danos causados por níveis reais mais elevados que os níveis declarados, não tendo ela própria nenhum controle sobre a utilização das máquinas.

FIN ILMOITETUT MELU- JA TÄRYRVOT :

Nämä arvot on mitattu koelaboratoriossa nykyisten lakinormien mukaisesti. Näitä arvoja ei voi missään tapauksessa käyttää riskien arviointiin. Arvot mitattuna työtilanteissa voivat olla ilmoitettuja mitta-arvoja korkeammat. Todelliset värinään altistumisen aiheuttamat fyysiset vauriot riippuvat työskentelytavasta, työstetystä osasta ja sen muodosta, sekä altistumisajasta ja työskentelijän fyysisistä kapasiteeteista. **GEORGES RENAULT** yhtiötä ei voida laittaa vastuuseen vaurioista jotka ovat seurausta ilmoitettuja arvoja korkeammista työskentelyarvoista, koska GEORGE RENAULT ei voi kontrolloida laitteiden käyttöä.

S DEKLARERAD BULLERNIVÅ OCH VIBRATIONSEMISSION :

Dessa värden har mätts upp av ett provningslaboratorium i enlighet med gällande normer, de kan aldrig användas för utvärdering av risker. De uppmätta värdena vid arbete kan vara högre än de deklarerade värdena. De verkliga exponeringsvärdena och de fysiska skador som uppstår till följd av vibrationer, är specifika och beror på det sätt på vilket användaren arbetar, den bearbetade detaljen och dess form, samt exponeringstiden och användarens fysiska kapacitet. Företaget **GEORGES RENAULT**, kan inte hållas ansvarig för skador förorsakade av högre verkliga nivåer än de deklarerade nivåerna, eftersom det inte har någon kontroll över användningen av maskinerna.

N LYD OG VIBRASJONSDEKLARASJON:

De oppgitte verdiene er laboratorieverdier i henhold til nevnte standarder, og er ikke adekvate for bruk i risikovurderinger. Verdier målt på den enkelte arbeidsplass kan være høyere enn de oppgitte verdiene. De aktuelle eksponeringsverdier og individuell skaderisiko er unike, og avhenger av måten brukeren arbeider på, av selve arbeidsstykket og av arbeidsplassens utforming, samt av eksponeringstid og brukernes fysiske kondisjon. Vi, **GEORGES RENAULT**, kan ikke holdes ansvarlig for konsekvensene ved bruk av reelle verdier som er høyere enn de oppgitte i en eventuell risikovurdering av en arbeidssituasjon som ligger utenfor vår kontroll.

DK DEKLARERET STØJNIVEAU OG VIBRATIONSUDSENDELSE:

Disse værdier måles af et forsøgslaboratorium i overensstemmelse med gældende normer, og de kan under ingen omstændigheder anvendes til vurdering af risici. De målte værdier under arbejde kan være højere end de deklarerede værdier. De reelle værdier for udsættelse og de fysiske skader, der følger af udsættelse for vibrationer, er specifikke og afhænger af den måde, brugeren arbejder på, det bearbejdede emne og dets form samt varigheden af udsættelse og brugerens fysiske evne. Selskabet **GEORGES RENAULT** kan ikke holdes ansvarlig for skader forårsaget af reelle niveauer, der er højere end de deklarerede niveauer, da det ikke selv har nogen kontrol over brugen af maskinerne.

NL VERKLAARDE GELUIDS- EN TRILLINGSWAARDEN:

Deze waarden zijn gemeten door een testlaboratorium in overeenstemming met de geldige normen en kunnen in geen geval gebruikt worden voor het evalueren van risico's. De tijdens het werk gemeten waarden kunnen hoger zijn dan de verklaarde waarden. De werkelijke waarden en de lichamelijke risico's van blootstelling aan trillingen zijn specifiek en afhankelijk van zowel de werkwijze van de gebruiker, van het werkstuk en van zijn lichamelijke conditie als van de duur van blootstelling en de fysieke capaciteiten van de gebruiker. De firma **GEORGES RENAULT** kan niet verantwoordelijk gesteld worden voor schade veroorzaakt door werkelijke waarden, die hoger blijken te zijn dan de verklaarde waarden, daar zij zelf geen enkele controle heeft over het gebruik van de machines.

GR ΤΙΜΕΣ ΣΤΑΘΜΗΣ ΘΟΡΥΒΟΥ ΚΑΙ ΚΡΑΔΑΣΜΩΝ ΠΟΥ ΔΗΛΩΝΟΝΤΑΙ ΑΠΟ ΤΟΝ ΚΑΤΑΣΚΕΥΑΣΤΗ:

Αν και οι τιμές αυτές μετρήθηκαν σε εργαστήριο δοκιμών και σύμφωνα με τα ισχύοντα πρότυπα, δεν πρέπει σε καμία περίπτωση να χρησιμοποιηθούν για την αξιολόγηση των ενδεχόμενων κινδύνων. Οι τιμές που μετρούνται κατά την εργασία ενδέχεται να είναι υψηλότερες από αυτές που δηλώθηκαν. Οι πραγματικές τιμές έκθεσης και οι σωματικές βλάβες που προκαλούνται από την έκθεση στους κραδασμούς είναι ειδικές και εξαρτώνται από τον τρόπο, το είδος και τη μορφή του υλικού που κατεργάζεται το εργαλείο, καθώς επίσης και από το χρόνο έκθεσης και τη φυσική κατάσταση του χρήστη. Η εταιρεία **GEORGES RENAULT** δεν φέρει ευθύνη για βλάβες που οφείλονται σε πραγματικές τιμές υψηλότερες από τις δηλούμενες, καθώς δεν μπορεί να ελέγξει τον τρόπο χρήσης των μηχανημάτων.

KA313EC4 – KA320-7 – KA312-7 – KA312E7 – KA320E7
KA309-9 – KA320-9 – KA312-9 – KA320E9 – KA312E9

Série B
19 / 20



Niveaux de vibration
Vibration levels
Niveles de vibraciones
Vibrationspegel
Livelli di vibrazione
Níveis de vibração
Tärinätaso
Vibrationsnivåer
Vibrasjonsnivå
Vibrationsudsendelse
Vibratieniveaus
Μέγεθος κραδασμών

ISO 8662-8

Niveaux sonores
Sound levels
Niveles sonoros
Geräuschpegel
Livelli sonori
Níveis sonoros
Melutaso
Ljudnivåer
Lydnivå
Støjniveau
Geluidsniveaus
Στάθμη θορύβου

EN ISO 15744

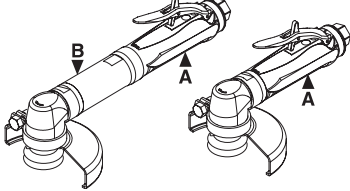
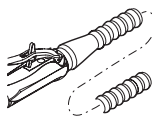
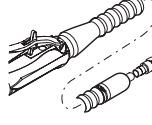
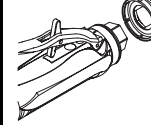
MODEL MODÈLE MODELO MODELL MALLI Μοντέλο			 6158751060 L_{pA} dB(A)	 Kit 6153961010 L_{pA} dB(A)	 Kit 6153961240 L_{pA} dB(A)	Masse Weight Masa Gewicht Massa Maa Vægt Vekt Βάρος	
	A m/s ²	B m/s ²				kg	lb
KA320E7	1	0,9	80	77	81	0,60	1.32
KA312E7	1,4	1	77	75	77	0,60	1.32
KA320-7	1,4	-	78	74	79	0,50	1.10
KA312-7	2,1	-	75	70	75	0,50	1.10
KA320E9	1,4	0,9	80	77	81	0,61	1.35
KA312E9	1,5	0,9	77	75	77	0,61	1.35
KA320-9	1,3	-	78	74	79	0,51	1.13
KA312-9	1,8	-	75	70	75	0,51	1.13
KA309-9	1,8	-	76	72	74	0,51	1.13
KA320EC3	2,0	1,6	80	77	80	0,81	1.78
KA318EC3	2,2	1,0	78	74	80	0,81	1.78
KA313EC4	1,8	1,2	79	77	78	0,83	1.83
KA320C3	2,5	-	78	76	80	0,64	1.41
KA318C3	2,5	-	81	79	82	0,64	1.41
KA313C4	1,8	-	79	76	78	0,66	1.45

L_{pA} : Niveau de pression acoustique, Sound pressure level, Nivel de presión sonora, Schalldruckpegel, Livello di pressione acustica, Nível de pressão acústica, Äänenpainetaso, Ljudtrycksnivå, Lydtrykksnivå, Lydtryksniveau, Geluidsdrukkniveau, Επίπεδο ακουστικής πίεσης dB(A)

$K_{pA} = 3$ dB : Incertitude, uncertainty, incertidumbre, Unsicherheit, incertezza, incerteza, epävarmuus, osäkerhet, usikkerhet, usikkerhed, onzekerheid, Αβεβαιότητα.

L_{WA} : Niveau de puissance acoustique, Sound power level, Nivel de presión sonora, Schalleistungspegel, Livello di potenza acustica, Nível de potência acústica, Äänen tehotaso, Ljudeffektnivå, Lydtrykknivå, Lydeffekt, Geluidsvermogeniveau, Επίπεδο ακουστικής ισχύος dB(A)

$K_{WA} = 3$ dB : Incertitude, uncertainty, incertidumbre, Unsicherheit, incertezza, incerteza, epävarmuus, osäkerhet, usikkerhet, usikkerhed, onzekerheid, Αβεβαιότητα.