

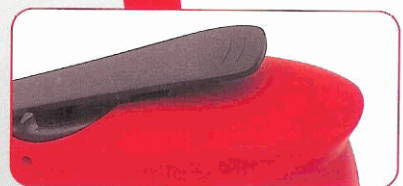

Lou Zampini & Associates
2 Douglas Pike, Rt. 7
Smithfield, RI 02917
1 800 353 4676
FAX 1 401 679 0165

RediPower Tools

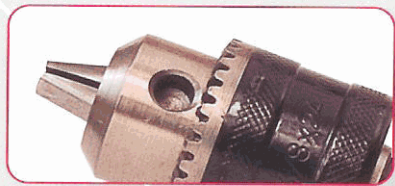



REDIPOWER™ INTRODUCTION

Redipower™ general-duty industrial power tools offer a full line of quality tools that allow you to match tool performance characteristics with your specific job requirements.

These tools are readily available when you want them, at a competitive price.

The vast range of Redipower™ tools provide effective solutions for many general industry applications. Combined with reliability, performance and after-sales service you can count on, you can be sure that you are selecting a quality product when you choose Redipower™.

A wide range of complimentary accessories such as air preparation equipment, airline hoses, sockets, screwdriver bits, etc. are also offered to provide a comprehensive solution.

Chicago Pneumatic/Desoutter in conjunction with a comprehensive network of distributors provide you with the local service and support you would expect to compliment Redipower™ tools.

For more information on tools, accessories, parts and service, or if you require assistance selecting the right tool for the job, or if anything is unclear after you have reviewed this catalogue contact your local authorized Chicago Pneumatic/Desoutter Industrial distributor.



RediPower Contents

Safety Instructions *page 2*

Impact Wrenches *page 4*

Ratchet Wrenches *page 6*

Screwdrivers *page 7*

Sanders *page 8*

Drills *page 9*

Grinders *page 11*

Hammers/Chippers/
Scalers *page 12*

Speciality Tools *page 13*

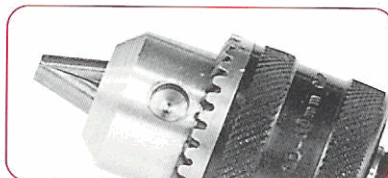
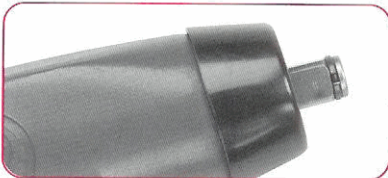
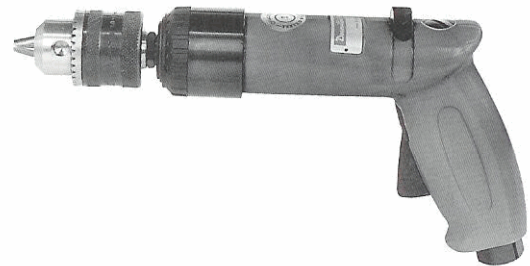

RediPower Safety Instructions

Specific Safety Instructions for Power Tool Groups

In addition to the General Safety Instructions, the following are safety instructions and warnings that apply to the safe operation of specific power tool groups.



Impact Wrenches

- Never use hand sockets. Use only impact sockets in good condition. Sockets in poor condition reduce impact power and could also shatter, resulting in personal injury.
- When using a universal joint, never operate the tool off the work. It may run too fast and cause the joint to be thrown from the tool.
- Always use the simplest hook up possible. Long springy extension bars and adapters absorb impact power and could break loose resulting in personal injury. Instead, use deep sockets wherever possible.
- For tools using the pin and o-ring socket retainer, use the o-ring to securely retain the socket pin or use a one-piece retainer ring to retain socket.
- Serious injury can result from over-torqued or under-torqued fasteners, which can break, or loosen and separate. Released assemblies can become projectiles. Assemblies requiring a specific torque must be checked using a torque meter.
NOTE: So-called "click" torque wrenches do not check for potentially dangerous over-torqued conditions.



Abrasive Tools

- Never mount a grinding wheel on a sander.
- Never use a grinding wheel rated at a speed lower than the air grinder speed.
- All grinding wheels and polishing/sanding accessories should be checked for cracks or other damage before mounting and use.
- Always use the recommended wheel guard to prevent injury when performing grinding operations. If a guard has withstood wheel or disk breakage, it must be replaced.
- Position a guard between the grinding wheel or disc and the

operator. Use barriers to protect others from fragments and grinding sparks.

- Make sure grinding wheels are mounted according to manufacturer's specifications; always use correct mounting flanges.
- Before grinding, test grinding wheel by briefly running tool at full throttle. Be sure to use a barrier (such as under a heavy worktable) to protect yourself from possible broken wheel parts.
- Never tamper with or remove a speed governor from a tool to make it run faster. Periodically check tool speed with a tachometer.



Ratchet Wrenches

- Never use hand sockets. Use only power drive sockets.
- To reduce the risk of injury, always support the handle securely in the direction opposite of the spindle rotation to minimize torque reaction.



Drills

- Keep away from rotating bit and chuck. You can become cut or burned if you come in contact with the drill bit, chips/swarf or work surface.
- Use intermittent drill pressure to avoid long shaved chips/swarf.
- The drill bit can suddenly bind and cause the work piece or tool to rotate causing arm and shoulder injuries.
- It is recommended that side handles are used for operator comfort and safety on high torque drilling applications above 2.6 lbft (3.5Nm) on straight case tools and 8.5lbft (11.5Nm) on pistol grip drills. Drills with a chuck capacity larger than 3/8" (10mm) should always be used with a side handle.



Hammers

- All chisels, rivet sets and other associated accessories should be checked for cracks, excessive wear,

or other physical damage before each use. Accessories that show signs of damage should be replaced immediately.

- Never use a tool with out the proper accessory retainer.



Other Tools (e.g. Screwdrivers, Shears, Saws, etc.)

- Specific instructions/warnings affecting this group of tools are contained in product-specific documents accompanying each product.



Accessories

- Always use accessories of correct size and design for the tool. Tool and accessories must not be modified in any way.
- Never use a tool without the proper accessory retainer.

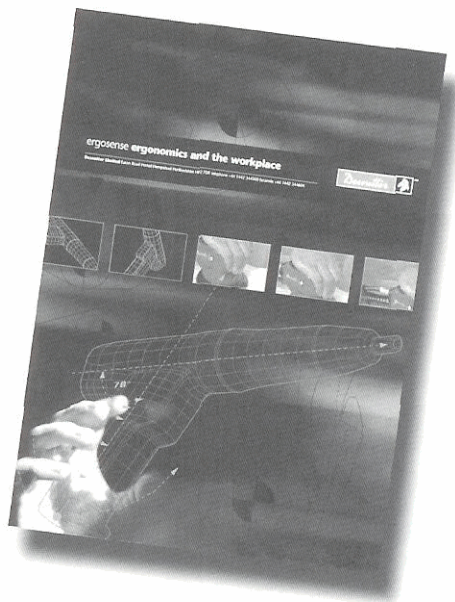

For information on Ergonomics and workplace design please ask for Desoutter publication LT198.

REDIPOWER™ IMPACT WRENCHES
A

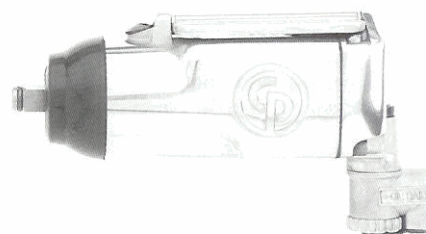
B

C

D

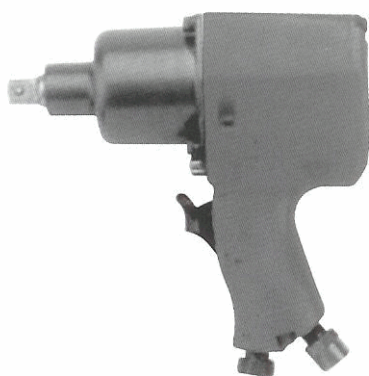
F

E

REDIPOWER – IMPACT WRENCHES – 3/8" AND 1/2" DRIVE
SPECIFICATION

PICTURE REF	MODEL	PART NUMBER	DRIVE	SOCKET RETAINER	WORKING TORQUE		MAXIMUM TORQUE		AIR CONSUMPTION		NOISE LEVEL	SOUND POWER	VIBRATION	OVERALL LENGTH		NET WEIGHT	
					ft lb	Nm	ft lb	Nm	cfm	l/s	dB(A)	dB(A)	ms ²	in.	mm	lb	kg
A	CP721	TO21963	3/8"	Friction Ring	5-50	6.8-70	90	122	10	4.7	84	94	4.9	5 3/4"	146	2 3/8	1.2
B	CP722	TO24190	3/8"	Friction Ring	5-50	6.8-70	90	122	10	4.7	86	96	2.5	5 3/4"	146	2	0.9
C	CP9524H	TO25382	3/8"	Friction Ring	20-160	27-217	200	272	12	5.7	94	104	<2.5	6.0	152	3.1	1.4
C	CP9524HP	TO25383	3/8"	Pin	20-160	27-217	200	272	12	5.7	94	104	<2.5	6.0	152	3.1	1.4
D	CP9526H	TO25384	1/2"	Friction Ring	20-160	27-217	200	272	12	5.7	94	104	<2.5	6.0	152	3.1	1.4
D	CP9526HP	TO25385	1/2"	Pin	20-160	27-217	200	272	12	5.7	94	104	<2.5	6.0	152	3.1	1.4
E	CP9541RS	TO22162	1/2"	Pin	20-180	27-245	275	374	14	6.6	89	99	2.7	6.6	168	5.5	2.5
E	CP9541RSS	TO22163	1/2"	Friction Ring	20-180	27-245	275	374	14	6.6	89	99	2.7	6.6	168	5.5	2.5
E	CP9541RSS	TO22164	7/16" hex	Quick Change	20-180	27-245	275	374	14	6.6	89	99	2.7	7.8	199	5.8	2.6
F	CP9540H	TO25377	1/2"	Friction Ring	25-310	34-420	425	576	15	7.1	90	100	3.4	7.5	191	5.1	2.3

RediPower Impact Wrenches

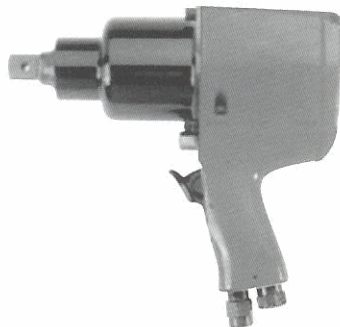
A



B

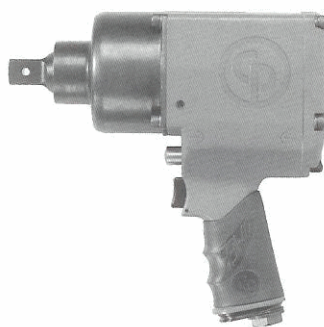

C



D

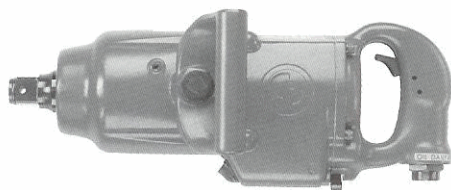

E

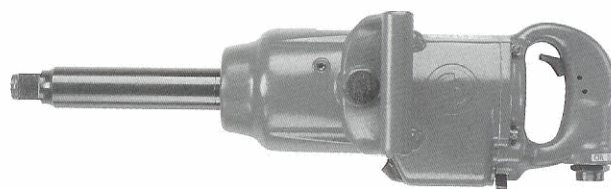

F

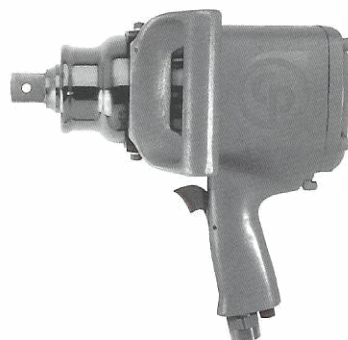

REDIPOWER – IMPACT WRENCHES – 3/4" AND 1" DRIVE

SPECIFICATION

PICTURE REF	MODEL	PART NUMBER	DRIVE	SOCKET RETAINER	WORKING TORQUE		MAXIMUM TORQUE		AIR CONSUMPTION		NOISE LEVEL	SOUND POWER	VIBRATION	OVERALL LENGTH		NET WEIGHT	
					ft lb	Nm	ft lb	Nm	cfm	l/s	dB(A)	dB(A)	ms ⁻²	in.	mm	lb	kg
A	CP9561RS	TO22235	3/4"	Hole	75-500	102-680	750	1020	30	14.1	100	110	5.1	8.5	216	10.5	4.8
B	CP6700RS	TO25306	3/4"	Hole	100-600	135-810	950	1285	39	18.4	97	107	7.6	8.9	226	12.6	5.75
B	CP6700RS1	TO25308	1"	Hole	100-600	135-810	950	1285	39	18.4	97	107	7.6	8.9	226	12.6	5.75
B	CP6700RSR	TO25307	3/4"	Friction Ring	100-600	135-810	950	1285	39	18.4	97	107	7.6	8.9	226	12.6	5.75
C	CP9560H	TO25381	3/4"	Friction Ring	150-700	200-950	1000	1360	24	11.3	99	109	4.9	9.6	244	10.5	4.8
D	CP9582	TO25386	1"	Friction Ring/Hole	150-900	200-1225	1400	1900	40	18.9	110	120	4.3	15.5	394	27.0	12.3
E	CP9582-6	TO25387	1"	Friction Ring	150-900	200-1225	1400	1900	40	18.9	110	120	4.3	22.2	564	29.8	13.5
F	CP9596RS	TO20427	1"	Hole	280-1800	380-2450	2800	3790	48	22.7	101	111	13.0	9.5	241	20.0	9.1
F	CP9596RLS	TO20428	#5 Spline	Integral	280-1800	380-2450	2800	3790	48	22.7	101	111	13.0	9.5	241	20.0	9.1

REDIPOWER RATCHET WRENCHES

A

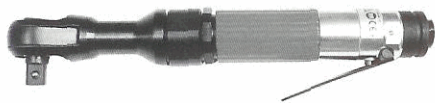

B

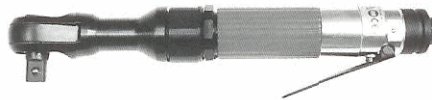

C



D

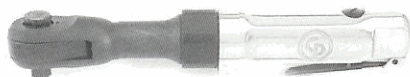

E



F

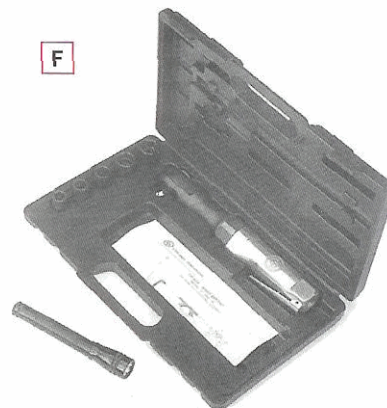

TOOL SELECTION

	DRIVE	STANDARD DUTY	HEAVY DUTY	INDUSTRIAL DUTY	REAR EXHAUST
	sq.				
2084	3/8"			✓	✓
2094	1/2"			✓	✓
CP825	1/4"	✓			
CP828	3/8"		✓		
CP828H	1/2"		✓		

REDIPOWER – RATCHET WRENCHES

SPECIFICATION

PICTURE REF	MODEL	PART NO	SQUARE DRIVE	FREE SPEED	TORQUE RANGE				AIR CONSUMPTION		NOISE LEVEL	SOUND POWER	VIBRATION	OVERALL LENGTH		NET WEIGHT	
			in.		rpm	ftlb	Nm	ftlb	Nm	cfm				ls ⁻¹	dB(A)	dB(A)	ms ⁻²
A	2084	2084	3/8"	140			27	37	19	9	82		8.2	10.9	278	2.4	1.1
B	2094	2094	1/2"	140			27	37	19	9	82		8.2	10.9	278	2.4	1.1
C	CP825	TO23145	1/4"	200	5	7	15	20	10	4.7	87	97	10	6 1/2"	165	1 1/8	0.85
D	CP828	TO22708	3/8"	150	10	14	50	68	16	7.5	92	102	10	10"	254	2 1/8	1.2
E	CP828H	TO22970	1/2"	150	10	14	50	68	16	7.5	92	102	10	10"	254	2 1/8	1.2

REDIPOWER – RATCHET WRENCH KIT

SPECIFICATION

PICTURE REF	MODEL	PART NO	SQUARE DRIVE	FREE SPEED	TORQUE RANGE				AIR CONSUMPTION		NOISE LEVEL	SOUND POWER	VIBRATION	OVERALL LENGTH		NET WEIGHT	
			in.		rpm	ftlb	Nm	ftlb	Nm	cfm				ls ⁻¹	dB(A)	dB(A)	ms ⁻²
F	CP828K	TO24493	3/8"	150	10	14	50	68	16	7.5	92	102	10	10"	254	2 1/2	1.2
F	CP828HK	TO24448	3/8"	150	10	14	50	68	16	7.5	92	102	10	10"	254	2 1/2	1.2

Note: CP828K (TO24493) includes 5 sockets – 3/8", 7/16", 1/2", 9/16" and 5/8" plus flashlight.
 CP828HK (TO24448) includes 5 sockets – 10, 13, 14, 16 and 17mm plus flashlight.

RediPower Screwdrivers

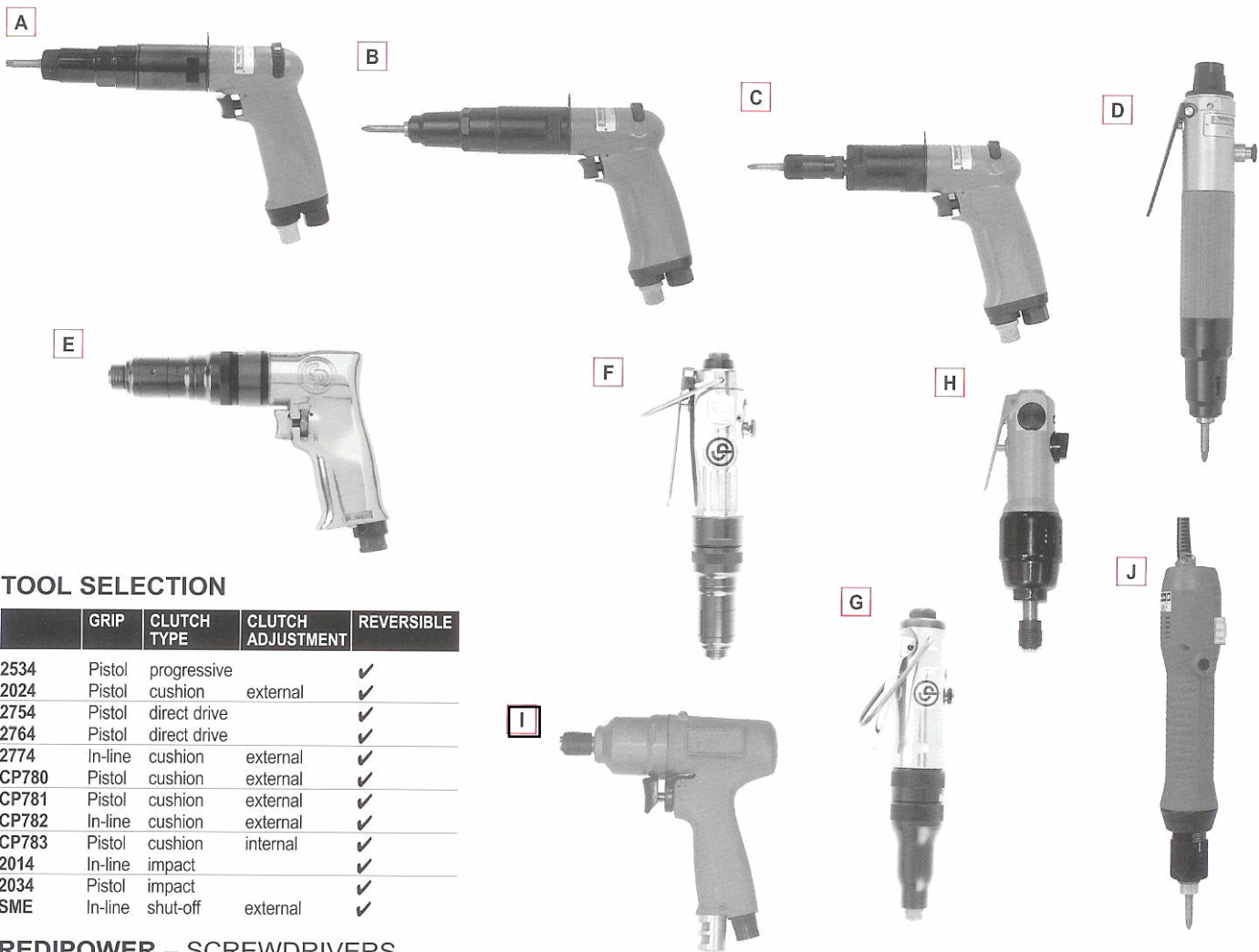

TOOL SELECTION

	GRIP	CLUTCH TYPE	CLUTCH ADJUSTMENT	REVERSIBLE
2534	Pistol	progressive		✓
2024	Pistol	cushion	external	✓
2754	Pistol	direct drive		✓
2764	Pistol	direct drive		✓
2774	In-line	cushion	external	✓
CP780	Pistol	cushion	external	✓
CP781	Pistol	cushion	external	✓
CP782	In-line	cushion	external	✓
CP783	Pistol	cushion	internal	✓
2014	In-line	impact		✓
2034	Pistol	impact		✓
SME	In-line	shut-off	external	✓

REDIPOWER – SCREWDRIVERS

SPECIFICATION

PICTURE REF	MODEL	PART NO	FREE SPEED	TORQUE RANGE		AIR CONSUMPTION		NOISE LEVEL	SOUND POWER	VIBRATION	OVERALL LENGTH		NET WEIGHT			
				MIN.	MAX.	cfm	l/s ⁻¹				in.	mm	lb	kg		
A	2534	2534	900		77	8.7	18	8.5	77		25.6	9.1	230	2.4	1.1	
B	2024	2024	900		60	6.8	17	8	77		<2.5	9.6	244	2.4	1.1	
C	2754	2754	1450		44	5.0	17	8	77		<2.5	8.3	210	2.0	0.9	
C	2764	2764	600		124	14.0	17	8	77		<2.5	9.0	228	2.2	1.0	
D	2774	2774	1050		60	6.8	17	8	73		4.2-10	9.6	244	2.2	1.0	
E	CP780	TO25095	1800	13	1.47	44	4.87	21	10	98.3	108.3	2.6	8.2	208	2.58	1.2
E	CP781	TO25096	800	14	1.55	100	11	20	9.4	99.5	109.5	<2.5	8.8	224	2.95	1.4
F	CP782	TO25097	1800	9.5	1.04	44	4.84	15.8	7.5	93.9	103.9	12	9.6	244	2.44	1.2
G	CP783	TO25098	2000	2.7	0.3	13	1.46	9.5	4.5	88.1	98.1	4.1	8.8	223	1.39	0.7
H	2014	1464724	10000	192	22	300	33	11.6	5.5	88	98	5	8.4	214	1.8	0.8
I	2034	1464734	11200	72	8	420	47	18.9	8.9	87	97	3.6	6.0	153	2.2	1.0

PICTURE REF	MODEL	PART NO	FREE SPEED	TORQUE RANGE		VOLTAGE	NOISE LEVEL	SOUND POWER	VIBRATION	OVERALL LENGTH		NET WEIGHT			
				MIN.	MAX.					in.	mm	lb	kg		
J	SME021-A1000-S4Q	1462224	1000	4.3	0.49	19.1	2.16	120	61		<2.5	10.4	264	2.3	1.05
J	SME029-A700-S4Q	1462234	700	8.7	0.98	26.0	2.94	120	60		<2.5	10.6	269	2.3	1.05
J	SME039-A500-S4Q	1462244	500	13.0	1.47	34.6	3.92	120	60		<2.5	10.6	269	2.3	1.05
J	SME021-A1000-S4Q	1458554	1000	4.3	0.49	19.1	2.16	230	61		<2.5	10.4	264	2.3	1.05
J	SME029-A700-S4Q	1458604	700	8.7	0.98	26.0	2.94	230	60		<2.5	10.6	269	2.3	1.05
J	SME039-A500-S4Q	1458624	500	13.0	1.47	34.6	3.92	230	60		<2.5	10.6	269	2.3	1.05

Note: 120V versions of SME not for sale within Europe.

A

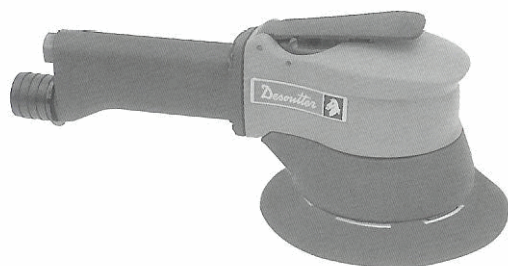

B

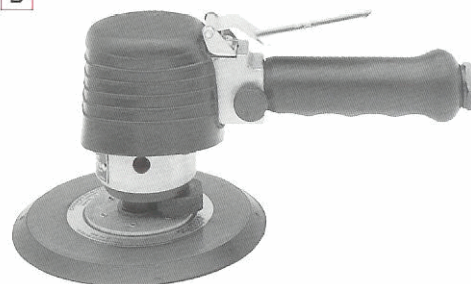

C



D

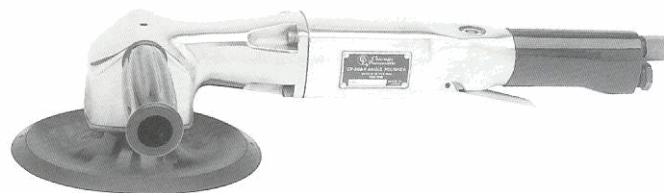

E



TOOL SELECTION

	GRIP	VACUUM	NON-VACUUM	ORBIT	
				in.	mm
5534*	Palm/handle	✓	✓	3/16"	5
5674*	Palm/handle	✓	✓	3/8"	10
CP864	Handle		✓	3/8"	10
CP865-S	Handle				
CP869-S	Handle				
CP778	Pistol				

* Note: models 5534 & 5674 are 4-in-1 modular sanders and can be self configured to handle or palm grip, vacuum or non-vacuum

REDIPOWER – SANDERS

SPECIFICATION

PICTURE REF	MODEL	PART NO	PAD SIZE		SPINDLE THREAD	FREE SPEED	AIR CONSUMPTION		NOISE LEVEL	SOUND POWER	VIBRATION	OVERALL LENGTH		NET WEIGHT	
			in.	mm			rpm	cfm				ls ⁻¹	dB(A)	dB(A)	ms ⁻²
A	5534	5534	6	150	5/16"-24	9000	19	8.97	83		<2.5	7.5	190	2.9	1.3
A	5674	5674	6	150	5/16"-24	9000	19	8.97	83		<2.5	7.5	190	2.9	1.3
B	CP864	TO22849	6	152	5/16"-24	10000	20	9.5	94	104	7			4	1.8
C	CP865-S	TO20491	7	178	5/8"-11	5000	24	11.3	89	99	<2.5	7.5	191	4.5	2.0
D	CP869-S	TO19387	7	178	5/8"-11	5000	24	11.3	89	99	<2.5	16	406	6.5	3.0
E	CP778	TO23048	5	127	7/16"-20	14000	24	11.3	96	106	2.9	6	152	2 1/4	1.0

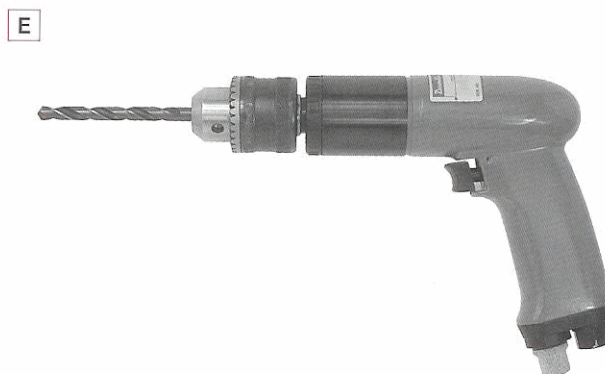
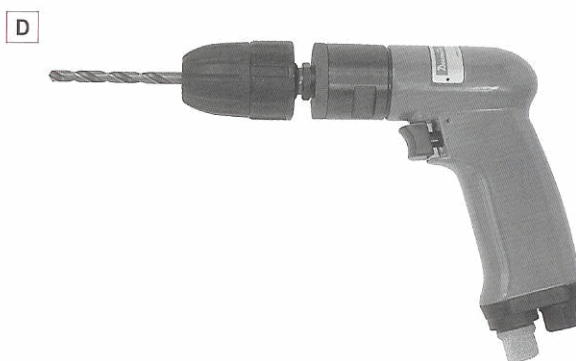
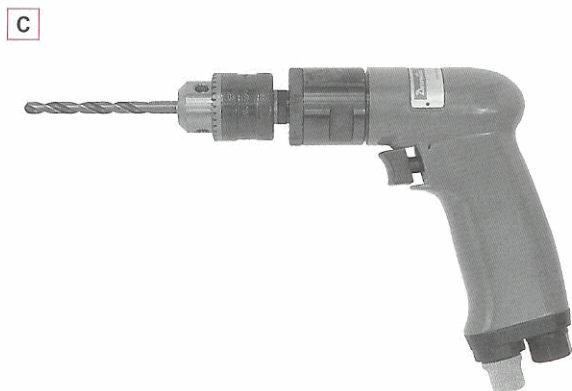
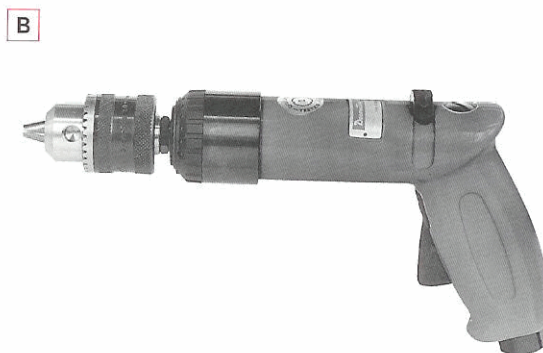
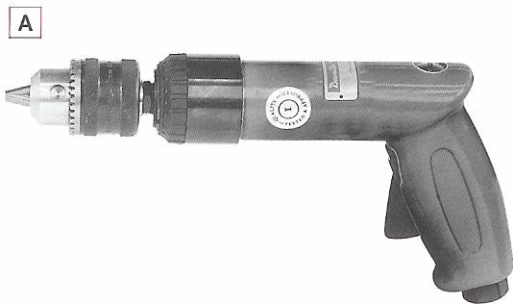

TOOL SELECTION

	GRIP	REVERSIBLE	KEYLESS CHUCK	GENERAL DUTY	HEAVY DUTY
1064	Slimline pistol			✓	
1454	Slimline pistol			✓	
1664	Slimline pistol	✓		✓	
1264	Pistol				✓
1274	Pistol		✓		✓
1404	Pistol				✓

REDIPOWER – DRILLS

SPECIFICATION

PICTURE REF	MODEL	PART NO	FREE SPEED	POWER		CHUCK CAPACITY		SPINDLE THREAD		AIR CONSUMPTION		NOISE LEVEL	VIBRATION	OVERALL LENGTH		NET WEIGHT	
				hp	kw	in.	mm			cfm	ls ⁻¹			dB(A)	ms ²	in.	mm
A	1064	1064	2500	0.30	0.23	10	3/8"	3/8"-24	19.7	9.3	83	<2.5	8.9	225	1.5	0.7	
A	1454	1454	4300	0.30	0.23	10	3/8"	3/8"-24	19.7	9.3	83	<2.5	8.9	225	1.5	0.7	
B	1664	1664	2000	0.26	0.19	10	3/8"	3/8"-24	19.7	9.3	83	<2.5	8.9	225	1.5	0.7	
C	1264	1264	2900	0.38	0.28	10	3/8"	3/8"-24	19.7	9.3	78	<2.5	6.9	175	2.0	0.9	
D	1274	1274	2900	0.38	0.28	10	3/8"	3/8"-24	19.7	9.3	78	<2.5	6.9	175	2.0	0.9	
E	1404	1404	1400	0.52	0.39	13	1/2"	3/8"-24	22.0	10.4	78	<2.5	9.6	243	2.9	1.3	

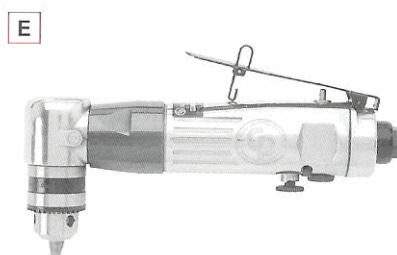
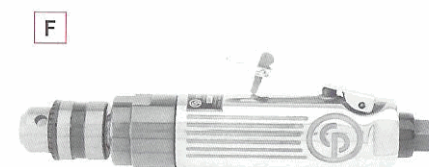
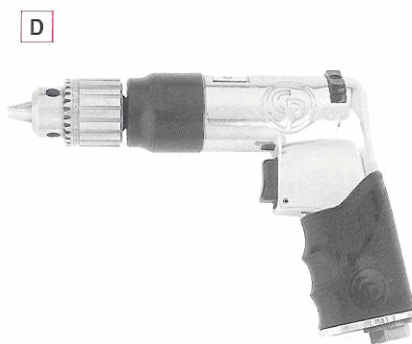
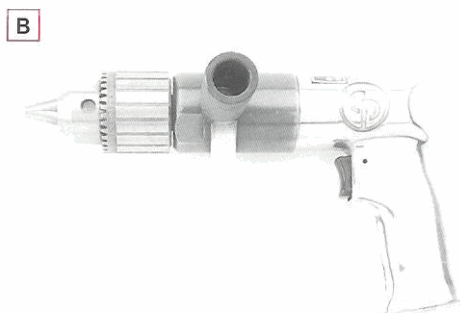
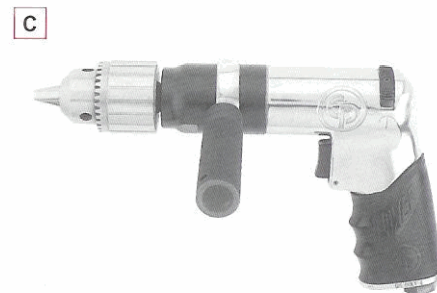
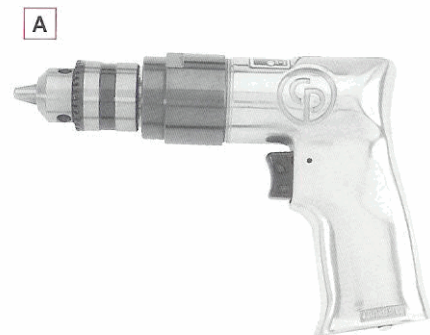

TOOL SELECTION

	GRIP	REVERSIBLE	GENERAL DUTY	HEAVY DUTY
CP785	Pistol		✓	
CP785H	Pistol		✓	
CP789HR	Pistol	✓		✓
CP789-26	Pistol	✓		✓
CP789-42	Pistol	✓		✓
CP879	Angle	✓	✓	
CP887	In-line		✓	

REDIPOWER – DRILLS

SPECIFICATION

PICTURE REF	MODEL	PART NO	FREE SPEED		POWER		CHUCK CAPACITY		SPINDLE THREAD		AIR CONSUMPTION		NOISE LEVEL	SOUND POWER	VIBRATION	OVERALL LENGTH		NET WEIGHT	
			rpm	hp	kw	in.	mm			cfm	ls ¹	dB(A)	dB(A)	ms ²	in.	mm	lb	kg	
A	CP785	TO22698	2400	0.5	0.37	3/8"	10	3/8"-24	12	5.7	90	100	<2.5	7	178	2 1/4	1		
B	CP785H	TO24134	500	0.5	0.37	1/2"	13	3/8"-24	12	5.7	91	101	<2.5	7 3/4	194	3	1.4		
C	CP789HR	TO25165	500	0.5	0.37	1/2"	13	3/8"-24	15	7.1	99	109	<2.5	8.1	206	3.2	1.5		
D	CP789-26	TO25180	2600	0.5	0.37	3/8"	10	3/8"-24	15	7.1	101	111	<2.5	6.9	175	2.5	1.1		
D	CP789-42	TO25198	4200	0.5	0.37	3/8"	10	3/8"-24	15	7.1	104	114	<2.5	6.9	175	2.5	1.1		
E	CP879	TO23999	1800	0.5	0.37	3/8"	10	3/8"-24	16	7.5	98	108	<2.5	8 1/4	206	2 1/4	1.0		
F	CP887	TO24163	2500	0.3	0.22	3/8"	10	3/8"-24	16	7.5	98	108	<2.5	8	200	2 1/4	1.0		

REDIPOWER GRINDERS

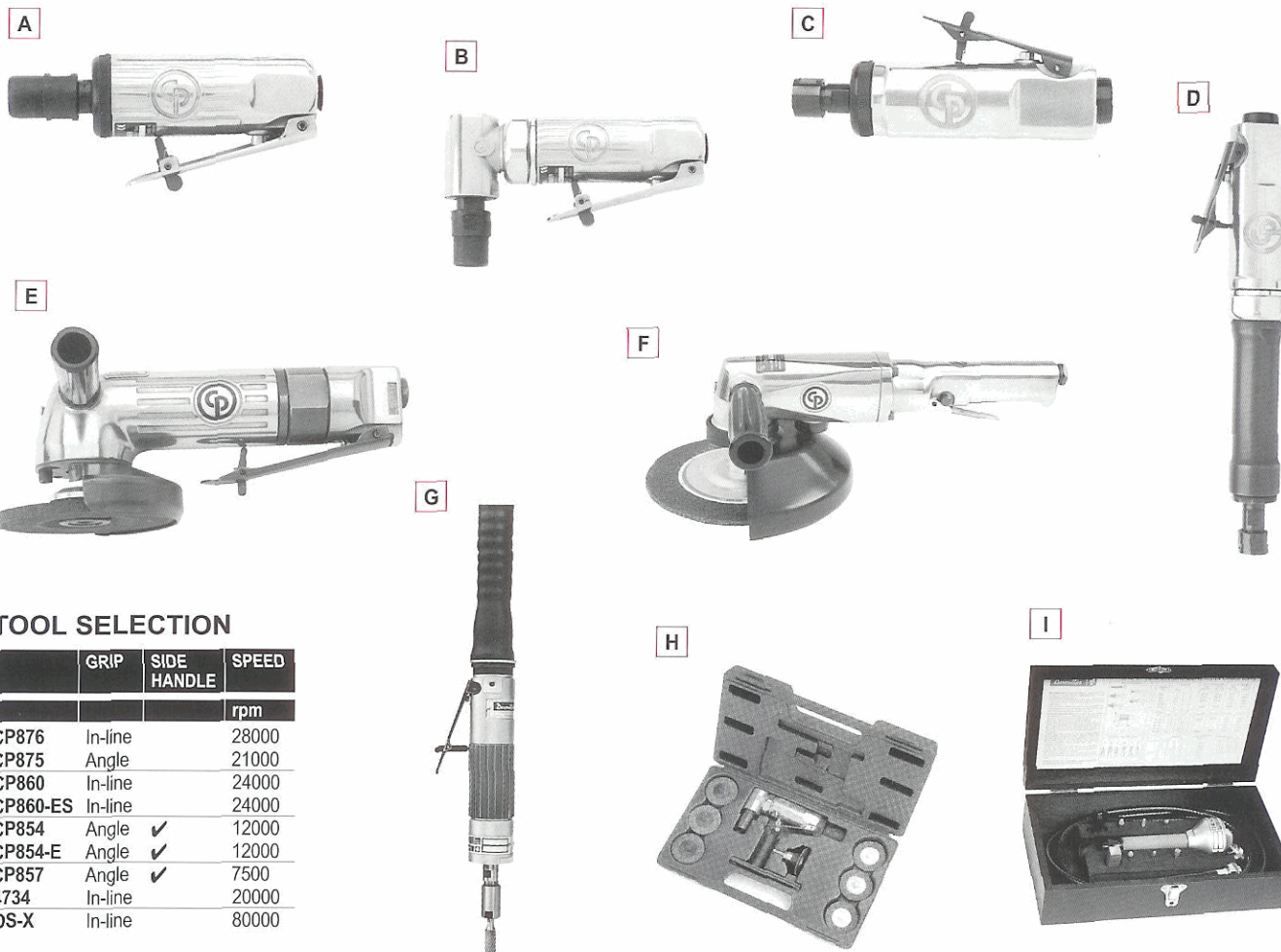

TOOL SELECTION

	GRIP	SIDE HANDLE	SPEED
			rpm
CP876	In-line		28000
CP875	Angle		21000
CP860	In-line		24000
CP860-ES	In-line		24000
CP854	Angle	✓	12000
CP854-E	Angle	✓	12000
CP857	Angle	✓	7500
4734	In-line		20000
OS-X	In-line		80000

REDIPOWER – GRINDERS

SPECIFICATION

PICTURE REF	MODEL	PART NO	POWER		COLLET/WHEEL SIZE		SPINDLE THREAD	AIR CONSUMPTION		NOISE LEVEL	SOUND POWER	VIBRATION	OVERALL LENGTH		NET WEIGHT	
			hp	kW	in.	mm		cfm	ls ⁻¹				dB(A)	dB(A)	ms ⁻²	in.
A	CP876	TO23996			1/4"	6	3/8"-24	16	7.5	101	111	<2.5	4 3/4"	119	3/4	0.3
B	CP875	TO23995			1/4"	6	3/8"-24	16	7.5	101	111	<2.5	4 7/8"	123	1	0.5
C	CP860	TO19704	0.5	0.37	1/4"		M10 x 1.25	20	9.4	90	100	3.0	5 1/4"	146	1 1/4	0.6
C	CP860E	TO21136	0.5	0.37		6	M10 x 1.25	20	9.4	90	100	3.0	5 1/4"	146	1 1/4	0.6
D	CP860ES	TO23193	0.5	0.37	1/4"		M10 x 1.25	20	9.4	93	103	2.5	11 3/4"	298	2 1/10	0.95
D	CP860ESE	TO23354	0.5	0.37		6	M10 x 1.25	20	9.4	93	103	2.5	11 3/4"	298	2 1/10	0.95
E	CP854	TO23186	0.6	0.45	4"	102	3/8"-24	24	11.3	85		<2.5	9"	229	3 3/4	1.7
E	CP854-E	TO23187	0.6	0.45	5"	127	M10	24	11.3	85		<2.5	9"	229	3 3/4	1.7
F	CP857	TO24387	1.25	0.93	7"	178	3/8"-11	33	15.6	102	112	4.2	13 1/8"	333	6 1/4	2.84
G	4734	4734	0.4	0.28	1/4"	6.4		18	8.5	77		3.4	8 1/2"	216	1.3	0.6

REDIPOWER – GRINDER KITS

SPECIFICATION

PICTURE REF	MODEL	PART NO	POWER		COLLET/WHEEL SIZE		SPINDLE THREAD	AIR CONSUMPTION		NOISE LEVEL	SOUND POWER	VIBRATION	OVERALL LENGTH		NET WEIGHT	
			hp	kW	in.	mm		cfm	ls ⁻¹				dB(A)	dB(A)	ms ⁻²	in.
H	CP875K	TO25115			1/4"	6	3/8"-24	16	7.5	101	111	<2.5	4 7/8"	123	1	0.5
I	O5-X-80000	258564	0.1	0.07	1/8"	3		5.9	2.8	76		2.7	6 1/4"	171	0.7	0.3

Note: CP875K includes 12 pcs 2" Quick-change disks, back-up pad and mandrel.
O5-X-80000 includes 6 mounted points and air supply hose.

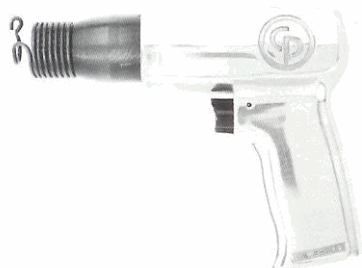
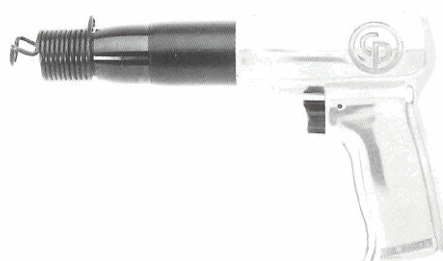
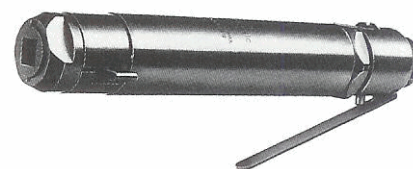
A

B

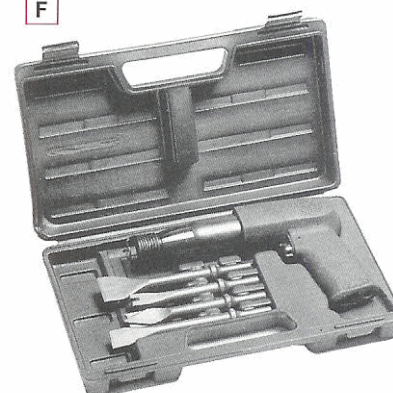
C

D

E

F

REDIPOWER – HAMMERS

SPECIFICATION

PICTURE REF	MODEL	PART NO	COLD RIVET CAPACITY DURAL		COLD RIVET CAPACITY STEEL		BORE AND STROKE		BLOWS PER MINUTE	CHISEL/ RIVET SET SHANK	AIR CONSUMPTION		NOISE LEVEL	SOUND POWER	VIBRATION	OVERALL LENGTH		NET WEIGHT	
			in.	mm	in.	mm	in.	mm			cfm	ls ⁻¹				db(a)	db(a)	ms ⁻²	in.
A	CP711	TO23305	1/4"	6.4	3/16"	4.8	3/4x2 5/8"	19x67	3500	.401	16	7.5	105	115	15.2	6 3/4"	171	3 1/2	1.6
A	CP711GS	TO23310	1/4"	6.4	3/16"	4.8	3/4x2 5/8"	19x67	3500	10mm hex	16	7.5	105	115	15.2	6 3/4"	171	3 1/2	1.6
B	CP715	TO23311	5/16"	7.9	1/4"	6.4	3/4x3 1/2"	19x89	2100	.401	18	8.5	109	119	13.7	8 7/8"	225	3 3/4	1.7
C	CP9356	TO21959					1x1 1/8"	25.4x28.6	4600	1/2" sq	15	7.1	101	111	16.7	9 3/8"	238	3 3/4	1.7
D	CP9356-NS	TO22165					1x1 1/8"	25.4x28.6	4600		15	7.1	101	111	16.7	17"	432	3 3/4	1.7

REDIPOWER – HAMMERS KITS

SPECIFICATION

PICTURE REF	MODEL	PART NO	COLD RIVET CAPACITY DURAL		COLD RIVET CAPACITY STEEL		BORE AND STROKE		BLOWS PER MINUTE	CHISEL/ RIVET SET SHANK	AIR CONSUMPTION		NOISE LEVEL	SOUND POWER	VIBRATION	OVERALL LENGTH		NET WEIGHT	
			in.	mm	in.	mm	in.	mm			cfm	ls ⁻¹				db(a)	db(a)	ms ⁻²	in.
E	CP711K	TO23756	1/4"	6.4	3/16"	4.8	3/4x2 5/8"	19x67	3500	.401	16	7.5	105	115	15.2	6 3/4"	171	3 1/2	1.6
F	CP715K	TO24381	5/16"	7.9	1/4"	6.4	3/4x3 1/2"	19x89	2100	.401	18	8.5	109	119	13.7	8 7/8"	225	3 3/4	1.7

Note: CP711K and CP715K kits include cold chisel, punch, edging chisel and rivet cutter.

A



B



D



C

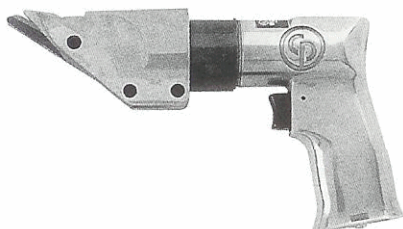

E

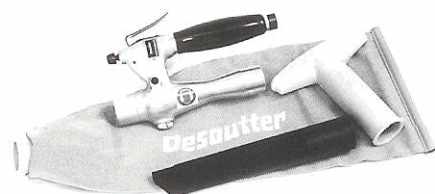

REDIPOWER – AIR SCRIBE

SPECIFICATION

PICTURE REF	MODEL	PART NO	AIR CONSUMPTION		NOISE LEVEL	VIBRATION	OVERALL LENGTH		NET WEIGHT	
			cfm	ls ⁻¹	dB(A)	ms ⁻²	in.	mm	lb	kg
A	CP-9361	TO12644	2.1	1	82	4.2	5"	127	0.3	0.14

REDIPOWER – AIR SCRIBE KIT

SPECIFICATION

PICTURE REF	MODEL	PART NO	AIR CONSUMPTION		NOISE LEVEL	VIBRATION	OVERALL LENGTH		NET WEIGHT	
			cfm	ls ⁻¹	dB(A)	ms ⁻²	in.	mm	lb	kg
B	CP9361-1	TO11970	2.1	1	82	4.2	5"	127	0.3	0.14

REDIPOWER – AIR SHEAR & RECIPROCATING SAW

SPECIFICATION

PICTURE REF	MODEL	PART NO	STROKES PER MINUTE	CAPACITY STEEL	AIR CONSUMPTION		NOISE LEVEL	SOUND POWER	VIBRATION	OVERALL LENGTH		NET WEIGHT	
					cfm	ls ⁻¹	dB(A)	dB(A)	ms ⁻²	in.	mm	lb	kg
C	CP785-S	TO23200	2400	18 gauge	12	5.7	87	97	4	8 1/4"	210	2 1/2"	1.1
D	CP881	TO23916	9500	16 gauge	24	11.3	95	105	11.4	8 5/8"	215	1 5/8"	.75

REDIPOWER – AIR VACUUM CLEANER

SPECIFICATION

PICTURE REF	MODEL	PART NO	AIR CONSUMPTION		NOISE LEVEL	OVERALL LENGTH		NET WEIGHT	
			cfm	ls ⁻¹	dB(A)	in.	mm	lb	kg
E	AV101	128534	12.5	5.9	90	7.9"	202	1.5	0.7

Note: CP9361 includes air supply hose. CP9361-1 includes air supply hose, flat chisel, chisel blank, round nose chisel & carbide tipped stylus