

RediPower Impact Wrenches

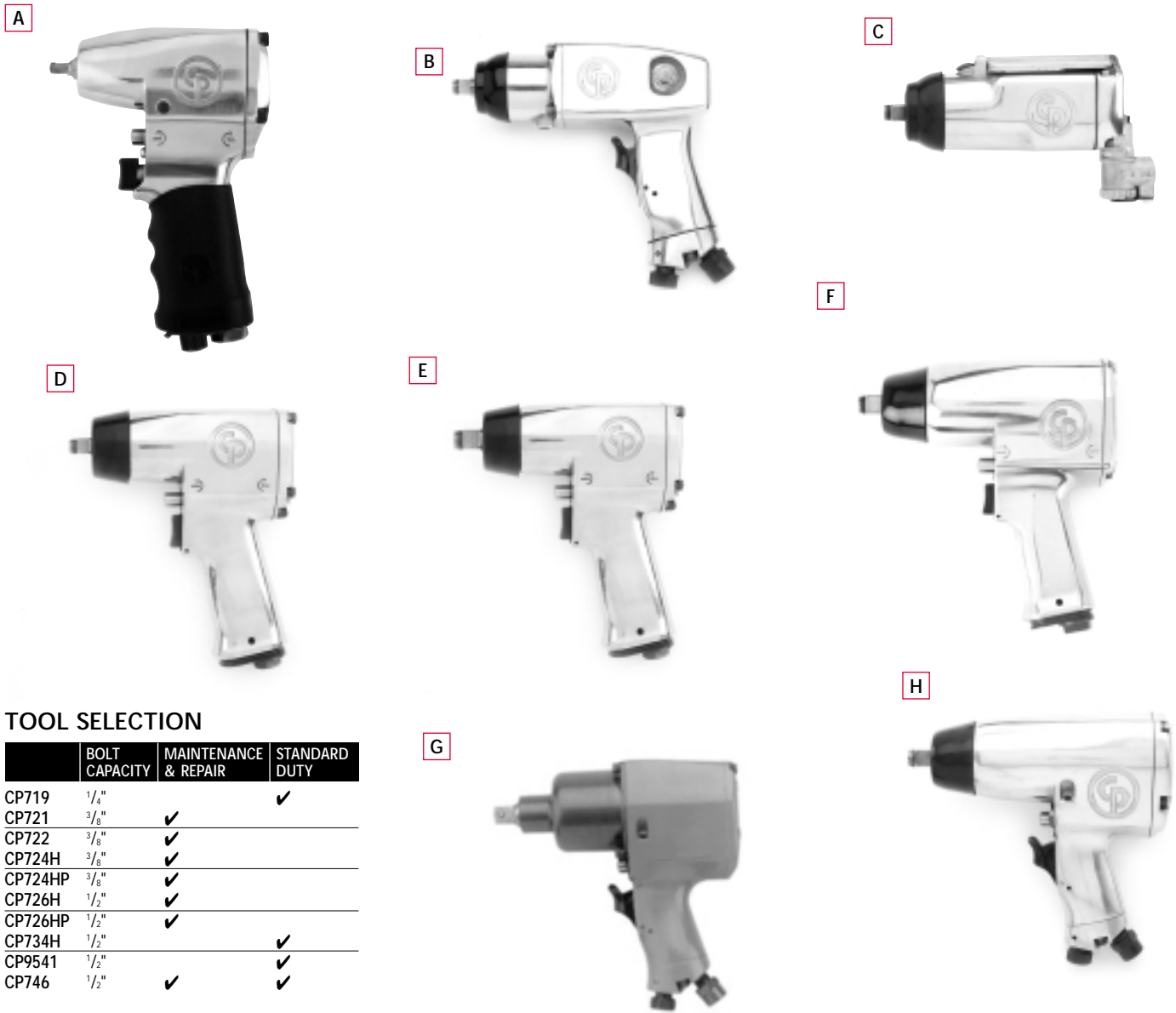

TOOL SELECTION

	BOLT CAPACITY	MAINTENANCE & REPAIR	STANDARD DUTY
CP719	1/4"		✓
CP721	3/8"	✓	
CP722	3/8"	✓	
CP724H	3/8"	✓	
CP724HP	3/8"	✓	
CP726H	1/2"	✓	
CP726HP	1/2"	✓	
CP734H	1/2"		✓
CP9541	1/2"		✓
CP746	1/2"	✓	✓

REDIPOWER – IMPACT WRENCHES

SPECIFICATION

PICTURE REF	MODEL	PART NO	SHANK SIZE	SHANK RETAINER TYPE	WORKING TORQUE		MAX TORQUE		AIR CONSUMPTION		NOISE LEVEL	SOUND POWER	VIBRATION	OVERALL LENGTH		NET WEIGHT	
					ftlb	Nm	ftlb	Nm	cfm	(ls ⁻¹)	dB(A)	dB(A)	ms ⁻²	in.	mm	lb	kg
A	CP719	TO25192	1/4"	Friction Ring	5-20	6.8-27	30	41	6	2.8	70	80	2.5	4 1/2"	113	2 1/2	1.1
B	CP721	TO21963	3/8"	Friction Ring	5-50	6.8-70	90	122	10	4.7	84	94	4.9	5 3/4"	146	2 5/8	1.2
C	CP722	TO24190	3/8"	Friction Ring	5-50	6.8-70	90	122	10	4.7	86	96	2.5	5 3/4"	146	2	0.9
D	CP724H	TO25113	3/8"	Friction Ring	20-160	27-217	180	245	10	4.7	94	104	<2.5	5 1/2"	138	3 1/10	1.4
D	CP724HP	TO25303	3/8"	Pin	20-160	27-217	180	245	10	4.7	94	104	<2.5	5 1/2"	138	3 1/10	1.4
E	CP726H	TO25114	1/2"	Friction Ring	20-160	27-217	200	272	10	4.7	94	104	<2.5	5 1/2"	138	3 1/5	1.5
E	CP726HP	TO25304	1/2"	Pin	20-160	27-217	200	272	10	4.7	94	104	<2.5	5 1/2"	138	3 1/5	1.5
F	CP734H	TO24351	1/2"	Friction Ring	25-310	34-422	425	578	14	6.6	90	100	3.4	6 3/4"	172	5	2.3
G	CP9541-RS	TO22162	1/2"	Pin	20-180	27-245	275	374	14	6.6	92	102	2.7	6 5/8"	168	5 1/2	2.5
G	CP9541-RSR	TO22163	1/2"	Friction Ring	20-180	27-245	275	374	14	6.6	92	102	2.7	6 5/8"	168	5 1/2	2.5
G	CP9541-RSS	TO22164	7/16"	Female Hex	20-180	27-245	275	374	14	6.6	92	102	2.7	7 1/8"	200	5 3/4	2.6
H	CP746	TO23591	1/2"	Friction	25-330	34-450	450	610	16	7.5	94	104	4.5	7 1/2"	194	5 1/2	2.5

RediPower Impact Wrenches

A



B



C



D



E



F



G



TOOL SELECTION

	BOLT CAPACITY	HEAVY DUTY	EXTRA HEAVY DUTY
CP772H	3/4"	✓	
CP9561	3/4"	✓	
CP9596-RS	1"		✓
CP9596-RLS	1"		✓
CP797	1"		✓
CP797-6	1"		✓

REDIPOWER – IMPACT WRENCHES

SPECIFICATION

PICTURE REF	MODEL	PART NO	SHANK SIZE	SHANK RETAINER TYPE	WORKING TORQUE		MAX TORQUE		AIR CONSUMPTION		NOISE LEVEL	SOUND POWER	VIBRATION	OVERALL LENGTH		NET WEIGHT	
					ftlb	Nm	ftlb	Nm	cfm	l/s	dB(A)	dB(A)	ms ⁻²	in.	mm	lb	kg
A	CP772H	TO24598	3/4"	Friction Ring	150-700	200-950	1000	1360	32	15.1	98	108	4.6	9 5/8"	244	10 1/2	4.8
B	CP9561-RS	TO22235	3/4"	Hole for Socket Pin	75-500	102-680	750	1020	30	14.1	100	110	5.1	8 1/2"	216	10 1/2	4.8
C	CP9596-RS	TO20427	1"	Hole for Socket Pin	280-1800	380-2450	2800	3808	48	22.6	101	111	13.0	9 1/2"	241	20	9.1
C	CP9596-RLS	TO20428	#5 Spline	Integral Pin	280-1800	380-2450	2800	3808	48	22.6	101	111	13.0	9 1/2"	241	20	9.1
D	CP797	TO19139	1"	Hole for Socket Pin	150-900	200-1225	1400	1900	48	22.6	110	120	4.3	15 1/2"	394	27	12.3
E	CP797-6	TO13901	1"	Friction Ring	150-900	200-1225	1400	1900	48	22.6	110	120	4.3	22 1/4"	556	29 3/4	13.5

REDIPOWER – IMPACT WRENCH KITS

SPECIFICATION

PICTURE REF	MODEL	PART NO	SHANK SIZE	SHANK RETAINER TYPE	WORKING TORQUE		MAX TORQUE		AIR CONSUMPTION		NOISE LEVEL	SOUND POWER	VIBRATION	OVERALL LENGTH		NET WEIGHT	
					ftlb	Nm	ftlb	Nm	cfm	l/s	dB(A)	dB(A)	ms ⁻²	in.	mm	lb	kg
F	CP734HK	TO25163	1/2"	Friction Ring	25-310	34-422	425	578	14	6.6	90	100	3.4	6 3/4"	172	5	2.3
F	CP734HK	TO25164	1/2"	Friction Ring	25-310	34-422	425	578	14	6.6	90	100	3.4	6 3/4"	172	5	2.3
G	CP772HK	TO25171	3/4"	Friction Ring	150-700	200-950	1000	1360	32	15.1	98	108	4.6	9 5/8"	244	10 1/2	4.8
G	CP772HK	TO25162	3/4"	Friction Ring	150-700	200-950	1000	1360	32	15.1	98	108	4.6	9 5/8"	244	10 1/2	4.8

Note: CP734HK (TO25163) includes 5 sockets – 1/2", 5/8", 3/4", 7/8" and 15/16" A/F.

CP734HK (TO25164) includes 5 sockets – 14, 16, 17, 19 and 22mm A/F.

CP772HK (TO25171) includes 4 sockets – 15/16", 1", 1 1/16", 1 1/8" A/F.

CP772HK (TO25162) includes 4 sockets – 24, 27, 30 and 32mm A/F.