

SLE Electric Screwdriver

Remote interface port
(options 2,3,4,5)

Switchable
supply voltage
AC230, 50Hz or
AC120, 60Hz

3 Button keypad
for simple
programming

LCD Display for
programming and
displaying cycle
parameters

Cycle complete
indicator

Wall mounting
bracket



- 5 Control options
- Password protected programming
- Automatic tool recognition
- Factory default reset facility
- Error codes to identify over current, short circuit, an EPROM error, final time timeout and errors during Fastening Assurance operation
- All units supplied with 11 languages within the program, English, German, Italian, French, Spanish, Swedish, Danish, Dutch, Finnish, Norwegian, Portuguese

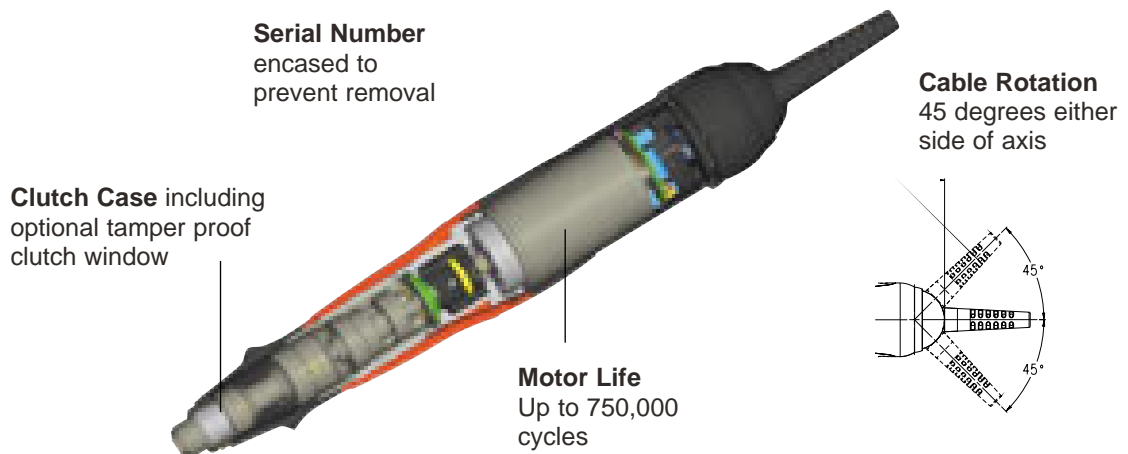

- Torque control options
 - Clutch control
 - Current to prevent shock loading on the component, permit 4 torques with a single tool, allow high torque during the rundown phase
- 5 Start options – push, button, lever, trigger, combination* (button/push, lever/push, trigger/push)

* Not available on angle head tools

SLE – High Power Screwdriver

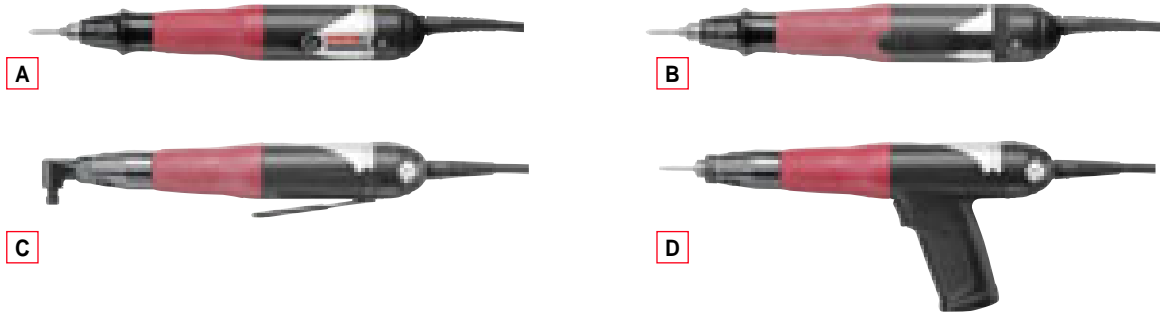

CLUTCH SHUT OFF – PUSH START

PICTURE REF	TOOL TYPE	PART NUMBER	FREE SPEED	OUTPUT	TORQUE RANGE	FITTED SPRING	WEIGHT	VOLTAGE	SOUND LEVEL	VIBRATION
			r/min	hex	Nm	Nm	kg	V DC	dB(A)	ms ⁻²
A	SLE012-A2000-S4Q	1464854	2000	1/4"	0.4-1.2	0.4-1.2	0.64	40	59	<2.5
A	SLE017-A1500-S4Q	1464864	1500	1/4"	0.4-1.7	0.4-1.7	0.64	40	59	<2.5
A	SLE023-A1000-S4Q	1464874	1000	1/4"	0.4-2.3	0.4-2.3	0.64	40	59	<2.5
A	SLE032-A750-S4Q	1464884	750	1/4"	0.4-3.2	1.5-3.2	0.64	40	59	<2.5
A	SLE047-A550-S4Q	1464894	550	1/4"	0.4-4.7	1.5-4.7	0.64	40	59	<2.5

CLUTCH SHUT OFF – LEVER START

PICTURE REF	TOOL TYPE	PART NUMBER	FREE SPEED	OUTPUT	TORQUE RANGE	FITTED SPRING	WEIGHT	VOLTAGE	SOUND LEVEL	VIBRATION
			r/min	hex	Nm	Nm	kg	V DC	dB(A)	ms ⁻²
B	SLE012-L2000-S4Q	1464904	2000	1/4"	0.4-1.2	0.4-1.2	0.68	40	59	<2.5
B	SLE017-L1500-S4Q	1464914	1500	1/4"	0.4-1.7	0.4-1.7	0.68	40	59	<2.5
B	SLE023-L1000-S4Q	1464924	1000	1/4"	0.4-2.3	0.4-2.3	0.68	40	59	<2.5
B	SLE032-L750-S4Q	1464934	750	1/4"	0.4-3.2	1.5-3.2	0.68	40	59	<2.5
B	SLE047-L550-S4Q	1464944	550	1/4"	0.4-4.7	1.5-4.7	0.68	40	59	<2.5

CLUTCH SHUT OFF – ANGLE HEAD, LEVER START

PICTURE REF	TOOL TYPE	PART NUMBER	FREE SPEED	OUTPUT	TORQUE RANGE	FITTED SPRING	WEIGHT	VOLTAGE	SOUND LEVEL	VIBRATION
			r/min	hex	Nm	Nm	kg	V DC	dB(A)	ms ⁻²
C	SLE012-L2000-S90A4H	1464954	2000	1/4"	0.4-1.2	0.4-1.2	0.81	40	59	<2.5
C	SLE017-L1500-S90A4H	1464964	1500	1/4"	0.4-1.7	0.4-1.7	0.81	40	59	<2.5
C	SLE023-L1000-S90A4H	1464974	1000	1/4"	0.4-2.3	0.4-2.3	0.81	40	59	<2.5
C	SLE032-L750-S90A4H	1464984	750	1/4"	0.4-3.2	1.5-3.2	0.81	40	59	<2.5
C	SLE047-L550-S90A4H	1464994	550	1/4"	0.4-4.7	1.5-4.7	0.81	40	59	<2.5

CLUTCH SHUT OFF – PISTOL GRIP, TRIGGER START

PICTURE REF	TOOL TYPE	PART NUMBER	FREE SPEED	OUTPUT	TORQUE RANGE	FITTED SPRING	WEIGHT	VOLTAGE	SOUND LEVEL	VIBRATION
			r/min	hex	Nm	Nm	kg	V DC	dB(A)	ms ⁻²
D	SLE012-T2000-S4Q	1465004	2000	1/4"	0.4-1.2	0.4-1.2	0.71	40	59	<2.5
D	SLE017-T1500-S4Q	1465014	1500	1/4"	0.4-1.7	0.4-1.7	0.71	40	59	<2.5
D	SLE023-T1000-S4Q	1465024	1000	1/4"	0.4-2.3	0.4-2.3	0.71	40	59	<2.5
D	SLE032-T750-S4Q	1465034	750	1/4"	0.4-3.2	1.5-3.2	0.71	40	59	<2.5
D	SLE047-T550-S4Q	1465044	550	1/4"	0.4-4.7	1.5-4.7	0.71	40	59	<2.5

CURRENT CONTROL SHUT OFF – PUSH AND LEVER START

PICTURE REF	TOOL TYPE	PART NUMBER	FREE SPEED	OUTPUT	TORQUE RANGE HARD JOINT	TORQUE RANGE SOFT JOINT	WEIGHT	VOLTAGE	SOUND LEVEL	VIBRATION
			r/min	hex	Nm	Nm	kg	V DC	dB(A)	ms ⁻²
A	SLE026-A1500-C4Q	1465414	1500	1/4"	2.0-2.6	1.4-1.6	0.60	40	59	<2.5
A	SLE030-A1000-C4Q	1465424	1000	1/4"	2.4-3.0	1.8-2.1	0.60	40	59	<2.5
A	SLE036-A750-C4Q	1465434	750	1/4"	2.4-3.6	1.8-2.8	0.60	40	59	<2.5
A	SLE045-A550-C4Q	1465444	550	1/4"	2.4-4.5	1.9-3.8	0.60	40	59	<2.5
B	SLE026-L1500-C4Q	1465884	1500	1/4"	2.0-2.6	1.4-1.6	0.64	40	59	<2.5
B	SLE030-L1000-C4Q	1465894	1000	1/4"	2.4-3.0	1.8-2.1	0.64	40	59	<2.5
B	SLE036-L750-C4Q	1465904	750	1/4"	2.4-3.6	1.8-2.8	0.64	40	59	<2.5
B	SLE045-L550-C4Q	1465914	550	1/4"	2.4-4.5	1.9-3.8	0.64	40	59	<2.5

ESP7 – Programmable Controller

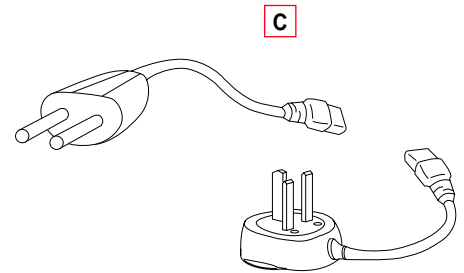

ESP7 PROGRAMMABLE CONTROLLER

PICTURE REF	DESCRIPTION	PART NUMBER	WEIGHT
A	ESP7	111362	5.1 kg

CONTROL CARDS

PICTURE REF	DESCRIPTION	PART NUMBER	WEIGHT
B	Option 2	108242	0.21 kg
B	Option 3 and 4	108252	0.25 kg
B	Option 5	108262	0.34 kg

POWER CABLE AND PLUG

PICTURE REF	DESCRIPTION	PART NUMBER	WEIGHT
C	UK Plug and Cable	396843	0.24 kg
C	USA Plug and Cable	459323	0.18 kg
C	European Plug and Cable	396853	0.26 kg

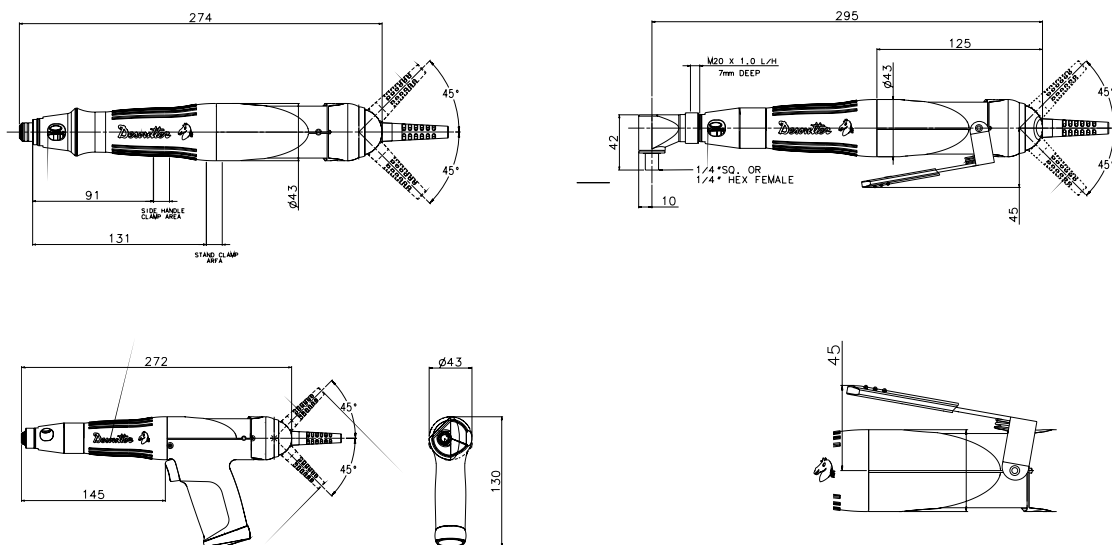

SLE

ACCESSORIES INCLUDED

	TOOL TYPES	PART NUMBER
• Clutch Adjustment Keys	All	69773
	All	443713
• Suspension Bail	All	443703
• Side Handle	550 r/min	467303
• Clutch Spring 0.4-2.5Nm	550/750 r/min	443523

OPTIONAL ACCESSORIES

	MODEL	PART NUMBER
• Lever Conversion Kit	Lever or Push Start	467853
• Trigger Conversion (4 parts required) 1. Pistol Grip 2. Switch Assembly 3. Trigger Assembly 4. Spring	Lever or Push Start	473803
		473743
		473843
		473923
• Angle Head 1/4" Hex Insert Drive	Lever or Trigger Start	475523
• Angle Head 1/4" Square Drive	Lever or Trigger Start	475513
• Spring Suspension Balancer	2DU	50522
• Reaction Free Self-Lock Balancer	2R	54422
• Suspension Shackle (43mm)	Fixed	6155710560
	Rotary	6153962280
• Tool Holster	DTH-42	107892
• D53 Stand, 220-580mm Reach	Standard Stand Assembly	388163
	Tool Clamp	384793
• D53X Stand, 175-650mm Reach	Extended Reach Assembly	388173
	Tool Clamp	384793
• D57 Balancing Arm, 400-700mm Reach	Standard Stand Assembly	408903
	Tool Clamp	409073
• D57X Balancing Arm, 450-850mm Reach	Extended Reach Assembly	408913
	Tool Clamp	409073
• D58 Balancing Arm with Swivel 500-750mm Reach	Standard Stand Assembly	408923
	Tool Clamp	409073
• Bench Mounted Swing Arm		66542
• Vacuum Pick Up	Vacuum Pick Up Kit	108892
	Finder Sleeve Blank – Plastic	464103

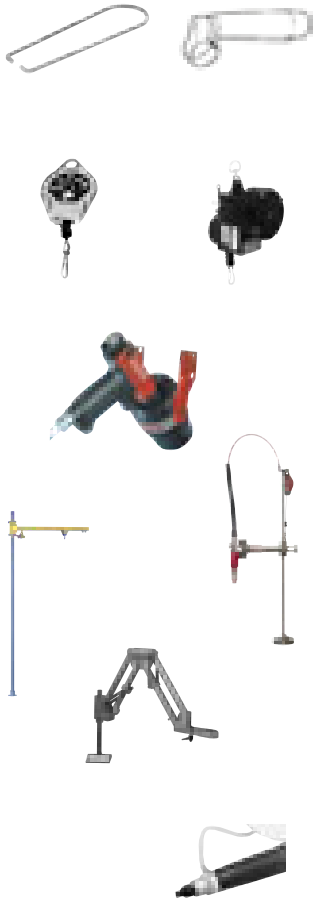

Safety Instructions

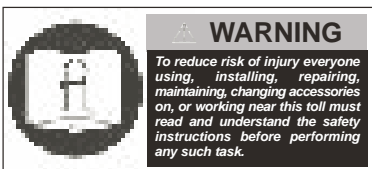

WARNING

To reduce risk of injury everyone using, installing, repairing, maintaining, changing accessories on, or working near this tool must read and understand the safety instructions before performing any such task.

Sound levels +/- 3dB(A)* measured in accordance with CAGI-PNEUROF test code or PNEUROF PN8NTC1.2. Vibration values* measured in accordance with ISO 8662.

*These declared values were obtained by laboratory testing in compliance with stated standards and are not adequate for risk assessments. Values measured in individual work places may be higher than the declared values. The actual exposure values and risk of harm experienced by an individual are unique

and depend upon the way the user works, the workpiece and the work station design, as well as upon the exposure time and the physical condition of the user. We Desoutter cannot be held liable for the consequences of using declared values, instead of values reflecting the actual exposure, in an individual risk assessment in a work place situation over which we have no control.

Tools are CE marked to comply with European Machinery Directive.

Specifications subject to change without prior notice.

Further occupational health and safety information can be obtained from the following web sites

<http://www.osha.gov> (USA)
<http://europe.osha.eu.int> (Europe).

For further information on the general safety instructions for the operation of power tools please refer to the Desoutter Fastening Tools Catalogue or the tool operating instructions supplied with the tool.



Control Options

OPTION 1 – Clutch Controlled Shut Off

Parameters Tool start mode
Outputs None
Inputs None

How to Order

1. Tool Clutch controlled types only
2. Controller ESP7, part no. 111362
3. Power Cable UK, part no. 396843/USA, part no. 459323/Europe, part no. 396853
4. Optional Accessories Balancers, tool holster, stands, vacuum pick up

OPTION 2 – Clutch Controlled Shut Off with Speed Control

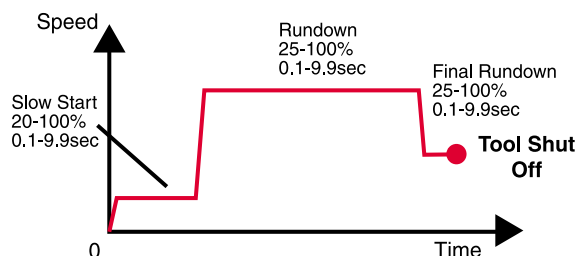

Parameters Tool start mode, external forward, reverse or stop signal functions, slow start time and speed, rundown time and speed, final rundown time and speed, reverse speed

Outputs Cycle finished, cycle not finished, ground 24V DC

Inputs External forward, external reverse, external stop, +24V DC

How to Order

1. Tool Clutch controlled types only
2. Controller ESP7, part no. 111362
3. Control Card Option 2, part no. 108242
4. Power Cable UK, part no. 396843/USA, part no. 459323/Europe, part no. 396853
5. Optional Accessories Balancers, tool holster, stands, vacuum pick up

OPTION 3 – Clutch Controlled Shut Off with Speed Control and Automatic Reverse Options OPTION 4 – Current Controlled Shut Off with Speed Control and Automatic Reverse Options

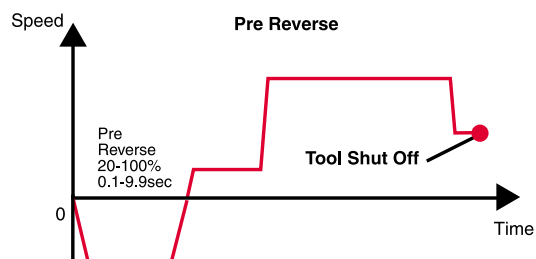
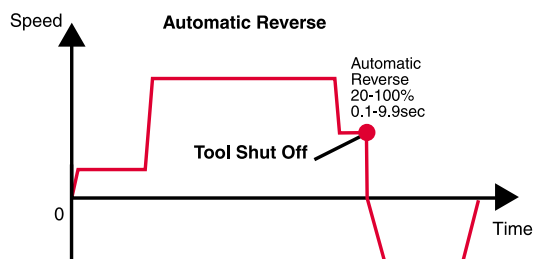

Parameters As per Option 2 plus program selection (maximum of 4), pre reverse time, automatic reverse time after shut off, current percentage (current control only)

Outputs Cycle finished, cycle not finished, ground 24V DC

Inputs External forward, external reverse, external stop, program selection, +24V DC

How to Order

- | | |
|-------------------------|--|
| 1. Tool | Option 3 – Clutch types, Option 4 – Current types |
| 2. Controller | ESP7, part no. 111362 |
| 3. Control Card | Options 3 and 4, part no. 108252 |
| 4. Power Cable | UK, part no. 396843/USA, part no. 459323/Europe, part no. 396853 |
| 5. Optional Accessories | Balancers, tool holster, stands, vacuum pick up |

OPTION 5 – Clutch or Current Controlled Shut Off with Speed Control and Automatic Reverse Option, High Torque Current Control and Fastening Assurance

This option has all the features of Options 3 and 4 plus:

High Torque Current Control

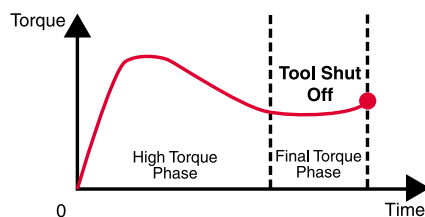

This function permits the current control tools to operate at a higher torque level during the rundown than the torque required at shut off.

Applications include those with thread forming screws, self tapping screws in thin materials or soft plastics, self lock nuts and screws, misaligned holes and fragile components.

Fastening Assurance System

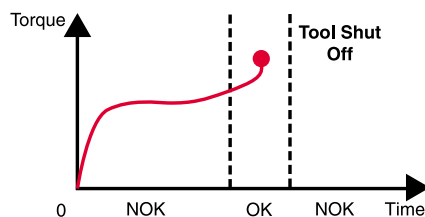

The fastening assurance system provides the ability to verify that all the fasteners in an assembly have been correctly fastened. By comparing the timing of electrical signals from the screwdriver with set parameters, the fastening cycle can be monitored and output signals generated for OK and NOK assembly confirmation. The output signals can then be combined to indicate that all the fasteners on the component have been tightened correctly.

Parameters As per Option 2, 3 and 4 plus enable FAS, enable high current, time limits for FAS, number of screws in a group (FAS), group start (FAS), NOK receipt to disable tool (FAS), permit sequencing of groups

Outputs As per Option 2, 3 and 4 plus n screws OK, n screws NOK

Inputs As per Option 2, 3 and 4 plus reset last, reset all, NOK receipt to acknowledge NOK, group start (maintained during cycle)

How to Order

- | | |
|-------------------------|--|
| 1. Tool | All types |
| 2. Controller | ESP7, part no. 111362 |
| 3. Control Card | Options 3 and 4, part no. 108242 |
| 4. Power Cable | UK, part no. 396843/USA, part no. 459323/Europe, part no. 396853 |
| 5. Optional Accessories | Balancers, tool holster, stands, vacuum pick up |



SLE Electric Screwdriver

