



## OPERATION AND MAINTENANCE MANUAL FOR SERIES 61H HORIZONTAL AIR GRINDERS

### NOTICE

Series 61H Horizontal Air Grinders are designed for heavy duty grinding in confined areas such as small castings or inside larger castings.

Ingersoll-Rand is not responsible for customer modification of tools for applications on which Ingersoll-Rand was not consulted.

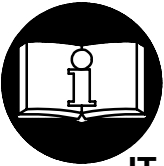

### ⚠ WARNING

**IMPORTANT SAFETY INFORMATION ENCLOSED.  
READ THIS MANUAL BEFORE OPERATING TOOL.**

**IT IS THE RESPONSIBILITY OF THE EMPLOYER TO PLACE THE INFORMATION  
IN THIS MANUAL INTO THE HANDS OF THE OPERATOR.**

**FAILURE TO OBSERVE THE FOLLOWING WARNINGS COULD RESULT IN INJURY.**

#### PLACING TOOL IN SERVICE

- Always operate, inspect and maintain this tool in accordance with American National Standards Institute Safety Code for Portable Air Tools (ANSI B186.1).
- For safety, top performance, and maximum durability of parts, operate this tool at 90 psig (6.2 bar/620 kPa) maximum air pressure at the inlet with 1/2" (13 mm) inside diameter air supply hose.
- Always turn off the air supply and disconnect the air supply hose before installing, removing or adjusting any accessory on this tool, or before performing any maintenance on this tool.
- Do not use damaged, frayed or deteriorated air hoses and fittings.
- Be sure all hoses and fittings are the correct size and are tightly secured. See Dwg. TPD905-1 for a typical piping arrangement.
- Always use clean, dry air at 90 psig (6.2 bar/620 kPa) maximum air pressure. Dust, corrosive fumes and/or excessive moisture can ruin the motor of an air tool.
- Do not lubricate tools with flammable or volatile liquids such as kerosene, diesel or jet fuel.
- Do not remove any labels. Replace any damaged label.

#### USING THE TOOL

- Always wear eye protection when operating or performing maintenance on this tool.
- Always wear hearing protection when operating this tool.
- Keep hands, loose clothing and long hair away from rotating end of tool.
- Anticipate and be alert for sudden changes in motion during start up and operation of any power tool.
- Keep body stance balanced and firm. Do not overreach when operating this tool. High reaction torques can occur at or below the recommended air pressure.
- Tool accessories may continue to rotate briefly after throttle is released.
- Air powered tools can vibrate in use. Vibration, repetitive motions or uncomfortable positions may be harmful to your hands and arms. Stop using any tool if discomfort, tingling feeling or pain occurs. Seek medical advice before resuming use.
- Use accessories recommended by Ingersoll-Rand.
- This tool is not designed for working in explosive atmospheres.
- This tool is not insulated against electric shock.

### NOTICE

The use of other than genuine Ingersoll-Rand replacement parts may result in safety hazards, decreased tool performance, and increased maintenance, and may invalidate all warranties.

Repairs should be made only by authorized trained personnel. Consult your nearest Ingersoll-Rand Authorized Servicenter.

Refer All Communications to the Nearest  
Ingersoll-Rand Office or Distributor.

© Ingersoll-Rand Company 2000

Printed in U.S.A.



## WARNING LABEL IDENTIFICATION

### ⚠ WARNING

FAILURE TO OBSERVE THE FOLLOWING WARNINGS COULD RESULT IN INJURY.

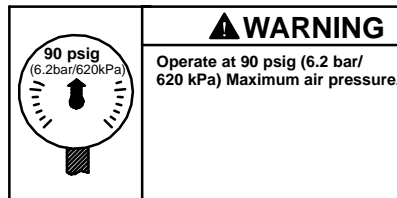
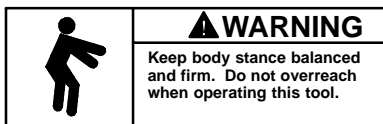
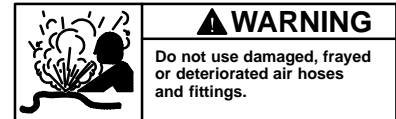
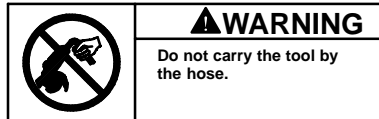
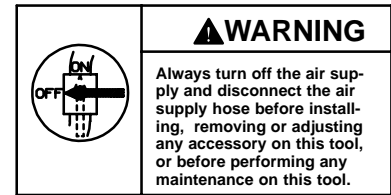
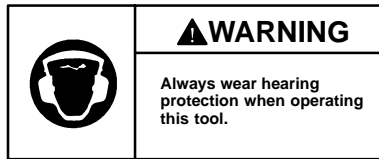
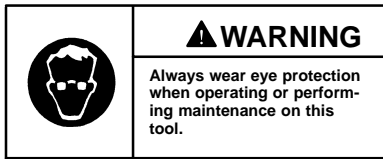

## GRINDER SPECIFIC WARNINGS

- Do not use this tool if the actual free speed exceeds the nameplate rpm.
- Before mounting a wheel, after all tool repairs and whenever a Grinder is issued for use, check the free speed of the Grinder with a tachometer to make certain its actual speed at 90 psig (6.2 bar/620 kPa) does not exceed the rpm stamped or printed on the nameplate. Grinders in use on the job must be similarly checked at least once each shift.
- Always use the Ingersoll-Rand Wheel Guard furnished with the Grinder.
- Do not use a Grinder without the recommended wheel guard. Do not use any wheel for which the operating speed listed on the blotter is lower than the actual free speed of the Grinder.
- Inspect all grinding wheels for chips or cracks prior to mounting. Do not use a wheel that is chipped or cracked or otherwise damaged. Do not use a wheel that has been soaked in water or any other liquid.
- Make certain the grinding wheel properly fits the arbor. The wheel should not fit too snugly or too loosely. Plain hole wheels should have about 0.007" (0.17 mm) maximum diametral clearance. Do not use reducing bushings to adapt a wheel to any arbor unless such bushings are supplied by or recommended by the wheel manufacturer.
- After mounting a new wheel, hold the Grinder under a steel workbench or inside a casting and run it for at least 60 seconds. Make certain no one is within the operating plane of the grinding wheel. If the wheel is defective, improperly mounted or the wrong size and speed, this is the time it will usually fail.
- When starting a cold wheel, apply it to the work slowly until the wheel gradually warms up. Make smooth contact with the work, and avoid any bumping action or excessive pressure.
- Always replace a damaged, bent or severely worn wheel guard. Do not use a wheel guard that has been subjected to a wheel failure.
- Make certain the wheel flanges are at least 1/3 the diameter of the grinding wheel, free of nicks and burrs and sharp edges. Always use the wheel flanges furnished by the manufacturer; never use a makeshift flange or a plain washer.
- Guard opening must face away from operator. Bottom of wheel must not project beyond guard.
- Always use a wheel blotter between each wheel flange and the wheel. The blotters must be at least as large in diameter as the wheel flanges.
- Do not attempt to disassemble the Controller. The Controller is available only as a unit and is guaranteed for the life of the tool if it is not abused.

## GRINDER SPECIFIC WARNINGS

**WARNING:** Incorrect combinations of grinding wheel, wheel guard and tool speed could result in injury. Correct combinations are specified below:

Guard Part Number	Wheel Type	Wheel Diameter in. (mm)	Maximum Wheel Thickness in. (mm)	Maximum Speed (rpm)
61H-931A	1	3 (76)	1/2 (12.7)	15,000

## PLACING TOOL IN SERVICE

### LUBRICATION



**Ingersoll-Rand No. 50    Ingersoll-Rand No. 68**

Always use an air line lubricator with these tools.  
We recommend the following Filter-Lubricator-Regulator Unit:

**USA No. – C28-04-FKG0-28**

**Before starting the tool,** unless the air line lubricator is used, detach the air hose and inject about 2.5 cc of Ingersoll-Rand No. 50 Oil into the air inlet. Remove the Oil Chamber Plug from the Throttle Handle and fill the chamber.

**After each eight hours of operation,** or as experience indicates, replenish the oil supply in the Handle.

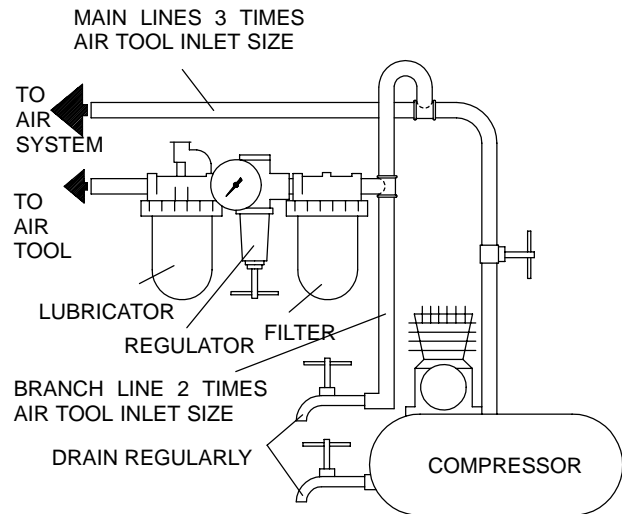

(Dwg. TPD905-1)

## HOW TO ORDER AN AIR GRINDER

### HORIZONTAL AIR GRINDER

Model	Free Speed rpm	Spindle
61H120G4	12,000	1/4" Erickson Collet
61H150G4	15,000	1/4" Erickson Collet
61H120L6	12,000	3/8-24 Spindle
61H150L6	15,000	3/8-24 Spindle
61H120H63	12,000	3/8-24 Spindle, 3" Guard
61H120H64	12,000	3/8-24 Spindle, 4" Guard
61H150H63	15,000	3/8-24 Spindle, 3" Guard

# MANUEL D'EXPLOITATION ET D'ENTRETIEN DES DES MEULEUSES PNEUMATIQUES HORIZONTALES DE LA SÉRIE 61H

## NOTE

Les meuleuses pneumatiques horizontales de la Série 61H sont destinées aux gros travaux de meulage dans les endroits restreints tels que sur de petites pièces coulées ou l'intérieur de grosses pièces coulées.

Ingersoll-Rand ne peut être tenu responsable de la modification des outils par le client pour les adapter à des applications qui n'ont pas été approuvées par Ingersoll-Rand.

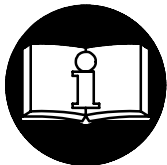

## ⚠ ATTENTION

**D'IMPORTANTES INFORMATIONS DE SÉCURITÉ SONT JOINTES.  
LIRE CE MANUEL AVANT D'UTILISER L'OUTIL.**

**L'EMPLOYEUR EST TENU DE COMMUNIQUER LES INFORMATIONS  
DE CE MANUEL AUX EMPLOYÉS UTILISANT CET OUTIL.**

**LE NON RESPECT DES AVERTISSEMENTS SUIVANTS PEUT CAUSER DES BLESSURES.**

### MISE EN SERVICE DE L'OUTIL

- Toujours exploiter, inspecter et entretenir cet outil conformément au Code de sécurité des outils pneumatiques portatifs de l'American National Standards Institute (ANSI B186.1).
- Pour la sécurité, les performances optimales et la durabilité maximale des pièces, cet outil doit être connecté à une alimentation d'air comprimé de 6,2 bar (620 kPa) maximum à l'entrée, avec un flexible de 13 mm de diamètre intérieur.
- Couper toujours l'alimentation d'air comprimé et débrancher le flexible d'alimentation avant d'installer, déposer ou ajuster tout accessoire sur cet outil, ou d'entreprendre une opération d'entretien quelconque sur l'outil.
- Ne pas utiliser des flexibles ou des raccords endommagés, effilochés ou détériorés.
- S'assurer que tous les flexibles et les raccords sont correctement dimensionnés et bien serrés. Voir Plan TPD905-1 pour un exemple type d'agencement des tuyauteries.
- Utiliser toujours de l'air sec et propre à une pression maximum de 6,2 bar (620 kPa). La poussière, les fumées corrosives et/ou une humidité excessive peuvent endommager le moteur d'un outil pneumatique.
- Ne jamais lubrifier les outils avec des liquides inflammables ou volatiles tels que le kérosène, le gasoil ou le carburant d'aviation.
- Ne retirer aucune étiquette. Remplacer toute étiquette endommagée.

### UTILISATION DE L'OUTIL

- Porter toujours des lunettes de protection pendant l'utilisation et l'entretien de cet outil.
- Porter toujours une protection acoustique pendant l'utilisation de cet outil.
- Tenir les mains, les vêtements fous et les cheveux longs, éloignés de l'extrémité rotative de l'outil.
- Prévoir, et ne pas oublier, que tout outil motorisé est susceptible d'à-coups brusques lors de sa mise en marche et pendant son utilisation.
- Garder une position équilibrée et ferme. Ne pas se pencher trop en avant pendant l'utilisation de cet outil. Des couples de réaction élevés peuvent se produire à, ou en dessous, de la pression d'air recommandée.
- La rotation des accessoires de l'outil peut continuer pendant un certain temps après le relâchement de la gâchette.
- Les outils pneumatiques peuvent vibrer pendant l'exploitation. Les vibrations, les mouvements répétitifs et les positions inconfortables peuvent causer des douleurs dans les mains et les bras. N'utiliser plus d'outils en cas d'inconfort, de picotements ou de douleurs. Consulter un médecin avant de recommencer à utiliser l'outil.
- Utiliser les accessoires recommandés par Ingersoll-Rand.
- Cet outil n'est pas conçu pour fonctionner dans des atmosphères explosives.
- Cet outil n'est pas isolé contre les chocs électriques.

## NOTE

L'utilisation de rechanges autres que les pièces d'origine Ingersoll-Rand peut causer des risques d'insécurité, réduire les performances de l'outil et augmenter l'entretien, et peut annuler toutes les garanties.

Les réparations ne doivent être effectuées que par des réparateurs qualifiés autorisés. Consultez votre Centre de Service Ingersoll-Rand le plus proche.

Adressez toutes vos communications au Bureau Ingersoll-Rand ou distributeur le plus proche.

© Ingersoll-Rand Company 2000

Imprimé aux É.U.



**To Buy Ingersoll Rand Products Online visit [AirToolPro.com](http://AirToolPro.com)**

Brought to you by Zampini Industrial Group - Factory Authorized Distribution Since 1987 - 1-800-353-4676

## SIGNIFICATION DES ETIQUETTES D'AVERTISSEMENT

### ATTENTION

LE NON RESPECT DES AVERTISSEMENTS SUIVANTS PEUT CAUSER DES BLESSURES.

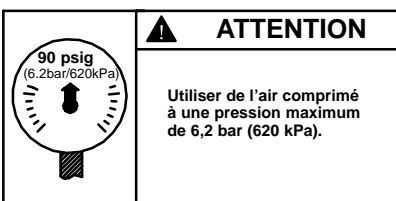
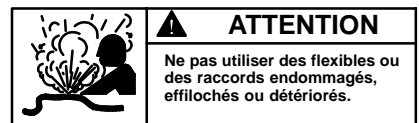
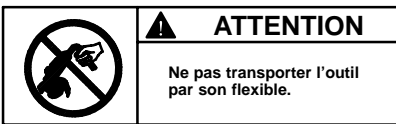
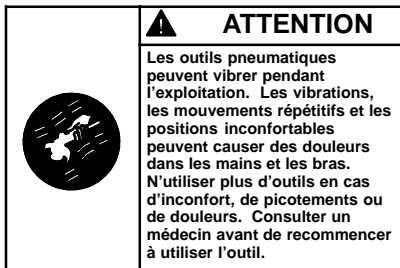
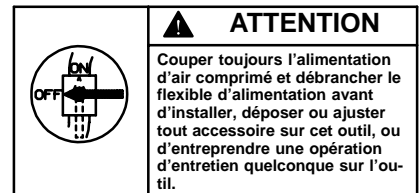
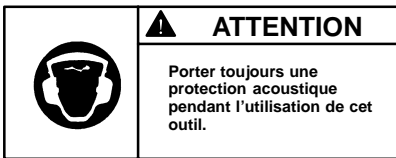
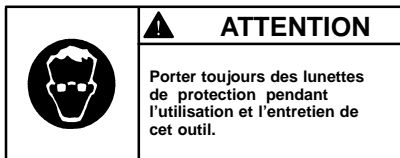

## AVERTISSEMENTS SPECIFIQUES AUX MEULEUSES

- Ne pas utiliser cet outil si la vitesse à vide réelle dépasse celle indiquée sur la plaque signalétique.
- Avant de monter une meule, après toute réparation de l'outil ou avant de fournir une meuleuse pour utilisation, vérifier la vitesse à vide de la meuleuse avec un tachymètre pour s'assurer que la vitesse réelle à 6,2 bar (620 kPa) ne dépasse pas celle poinçonnée ou imprimée sur la plaque signalétique. Les meuleuses sorties sur chantier doivent être vérifiées de la même façon au moins une fois par poste.
- Utiliser toujours le protège-meule Ingersoll-Rand fourni avec la meuleuse.
- Ne jamais utiliser une meuleuse sans son protège-meule recommandé. Ne jamais utiliser de meule dont la vitesse de fonctionnement imprimée sur l'étiquette est inférieure à la vitesse à vide de la meuleuse.
- Inspecter toutes les meules avant de les monter pour vérifier qu'elles ne présentent pas d'éclats ou de fissures. Ne jamais utiliser une meule écaillée, fissurée ou ayant un endommagement quelconque. Ne jamais utiliser une meule qui a été trempée dans l'eau ou tout autre liquide.
- S'assurer que la meule se monte correctement sur l'arbre. Le montage de la meule ne doit être ni serré ni libre. Les meules à trou lisse doivent présenter un jeu diamétral maximum de 0,17 mm. Ne pas utiliser de bagues réductrices, à moins que ces bagues soient recommandées et fournies par le fabricant de la meule.
- Après avoir monté une nouvelle meule, tenir la meuleuse sous un établi en acier ou dans une pièce coulée et la faire tourner pendant au moins 60 secondes. S'assurer que personne ne se tient dans le plan de rotation de la meule. Toute meule défectueuse, mal montée ou de dimension et vitesse incorrectes se cassera généralement à ce moment là.
- Pour commencer le travail avec une meule froide, l'appliquer lentement contre la pièce jusqu'à ce que la meule s'échauffe progressivement. Mettre la meule en contact avec la pièce en douceur en évitant tout choc ou pression excessive.
- Remplacer toujours un protège-meule endommagé, tordu ou très usé. Ne pas utiliser un protège-meule qui a été soumis à la rupture d'une meule.
- S'assurer que les flasques de meule couvrent au moins 1/3 du diamètre de la meule, et qu'ils sont exempts d'entailles, de bavures et d'arêtes vives. Utiliser toujours les flasques fournis par le fabricant; ne jamais utiliser de flasque de provenance douteuse ou de rondelle plate.
- L'ouverture du protège-meule doit être orientée côté opposé à l'opérateur. Le bas de la meule ne doit pas dépasser le protège-meule.
- Monter toujours un disque en buvard entre les flasques et la meule. Les disques doivent avoir un diamètre au moins égal à celui des flasques.
- Ne jamais essayer de démonter le contrôleur. Ce dernier est fourni seulement comme un ensemble et est garanti pendant toute la durée de vie de l'outil s'il est utilisé correctement.

## AVERTISSEMENTS SPECIFIQUES AUX MEULEUSES

**ATTENTION:** Une mauvaise combinaison de roue d'affûtage, de protection de roue et de vitesse de l'outil peut provoquer un accident corporel. Les combinaisons correctes sont spécifiées ci-dessous:

Référence de la protection	Type de roue	Diamètre de roue pouces (mm)	Epaisseur maximale de roue pouces (mm)	Vitesse maximale (t/min)
61H-931A	1	3 (76)	1/2 (12,7)	15.000

### MISE EN SERVICE DE L'OUTIL

#### LUBRIFICATION



Ingersoll-Rand No. 50



Ingersoll-Rand No. 68

Utiliser toujours un lubrificateur avec ces outils. Nous recommandons l'emploi du filtre-régulateur-lubrificateur suivant :

É.U. - N°. C28-04-FKG0-28

**Avant de mettre l'outil en marche**, si un lubrificateur de ligne n'est pas utilisé, débrancher le flexible d'alimentation et verser environ 2,5 cm<sup>3</sup> d'huile Ingersoll-Rand No. 50 dans le raccord d'admission de l'outil. Déposer le bouchon de la chambre d'huile de la poignée de commande et remplir la chambre d'huile.

**Toutes les huit heures de fonctionnement**, ou en fonction de l'expérience, remplir la réserve d'huile de la poignée.

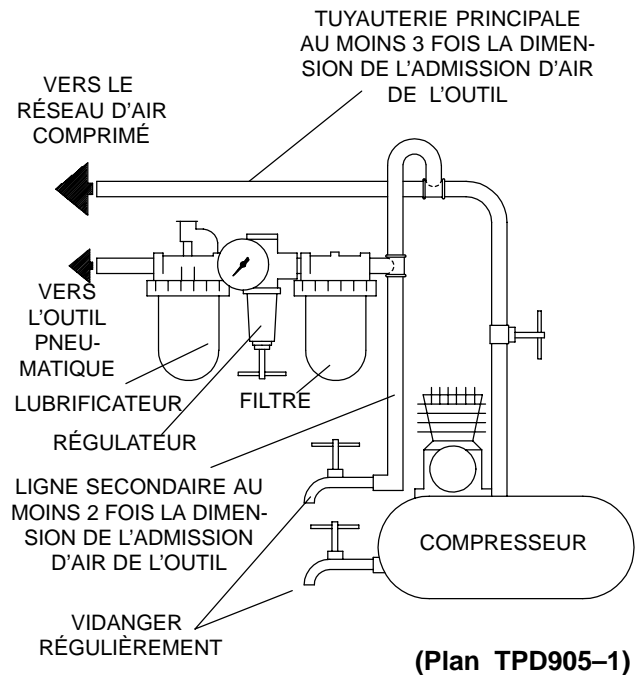

### SPÉCIFICATIONS

Modèle	Vitesse libre		Broche
	tr/mn		
61H120G4	12.000		Pince Erickson 1/4"
61H150G4	15.000		Pince Erickson 1/4"
61H120L6	12.000		Arbre fileté 3/8"-24 filets
61H150L6	15.000		Arbre fileté 3/8"-24 filets
61H120H63	12.000		Arbre fileté 3/8"-24 filets, protège-meule de 3"
61H120H64	12.000		Arbre fileté 3/8"-24 filets, protège-meule de 4"
61H150H63	15.000		Arbre fileté 3/8"-24 filets, protège-meule de 3"

# MANUAL DE USO Y MANTENIMIENTO PARA AMOLADORAS NEUMÁTICAS HORIZONTALES DE LA SERIE 61H

## NOTA

Las Amoladoras Neumáticas Horizontales de la serie 61H están diseñadas para trabajos de amolado industrial en espacios reducidos, tales como pequeñas piezas de fundición o en el interior de piezas de fundición de mayor tamaño.

Ingersoll–Rand no aceptará responsabilidad alguna por la modificación de las herramientas efectuada por el cliente para las aplicaciones que no hayan sido consultadas con Ingersoll–Rand.

## ⚠ AVISO

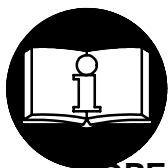

**SE ADJUNTA INFORMACIÓN IMPORTANTE DE SEGURIDAD.  
LEA ESTE MANUAL ANTES DE USAR LA HERRAMIENTA.  
ES RESPONSABILIDAD DE LA EMPRESA ASEGURARSE DE QUE EL  
OPERARIO ESTÉ AL TANTO DE LA INFORMACIÓN QUE CONTIENE ESTE MANUAL.  
EL HACER CASO OMISO DE LOS AVISOS SIGUIENTES PODRÍA OCASIONAR LESIONES.**

### PARA PONER LA HERRAMIENTA EN SERVICIO

- Utilice, examine y mantenga siempre esta herramienta conforme al código de seguridad para herramientas neumáticas portátiles de la American National Standards Institute (ANSI B186.1).
- Para seguridad, máximo rendimiento y vida de servicio de las piezas, use esta herramienta a una presión de aire máxima en la entrada de 90 psig (6,2 bar/620 kPa) con una manguera de suministro de aire con diámetro interno de 13 mm.
- Corte siempre el suministro de aire y desconecte la manguera de suministro de aire antes de instalar, desmontar o ajustar cualquier accesorio de esta herramienta, o antes de realizar cualquier operación de mantenimiento de la misma.
- No utilice mangueras de aire y racores dañados, desgastados ni deteriorados.
- Asegúrese que todas las mangueras y racores sean del tamaño correcto y estén bien apretados. Vea Esq. TPD905–1 para un típico arreglo de tuberías.
- Use siempre aire limpio y seco a una presión máxima de 90 psig (6,2 bar/620 kPa). El polvo, los gases corrosivos y/o el exceso de humedad podrían estropear el motor de una herramienta neumática.
- No lubrique las herramientas con líquidos inflamables o volátiles tales como queroseno, gasoil o combustible para motores a reacción.
- No saque ninguna etiqueta. Sustituya toda etiqueta dañada.

### USO DE LA HERRAMIENTA

- Use siempre protección ocular cuando utilice esta herramienta o realice operaciones de mantenimiento en la misma.
- Use siempre protección para los oídos cuando utilice esta herramienta.
- Mantenga las manos, la ropa suelta y el cabello largo alejados del extremo giratorio de la herramienta.
- Anticipe y esté alerta sobre los cambios repentinos en el movimiento durante la puesta en marcha y el manejo de toda herramienta motorizada.
- Mantenga una postura de cuerpo equilibrada y firme. No estire demasiado los brazos al manejar la herramienta. Pueden ocurrir reacciones de alto par a, o a menos de, la recomendada presión de aire.
- El eje de la herramienta podría seguir girando brevemente después de haber soltado la palanca de mando.
- Las herramientas neumáticas pueden vibrar durante el uso. La vibración, repetición o posiciones incómodas pueden dañarle los brazos y manos. En caso de incomodidad, sensación de hormigueo o dolor, deje de usar la herramienta. Consulte a un médico antes de volver a usarla otra vez.
- Utilice únicamente los accesorios Ingersoll–Rand recomendados.
- Esta herramienta no ha sido diseñada para trabajar en ambientes explosivos.
- Esta herramienta no está aislada contra descargas eléctricas.

## NOTA

El uso de piezas de recambio que no sean las auténticas piezas Ingersoll–Rand podría poner en peligro la seguridad, reducir el rendimiento de la herramienta y aumentar los cuidados de mantenimiento necesarios, así como invalidar toda garantía.

Las reparaciones sólo serán realizadas por personal cualificado y autorizado. Consulte con el centro de servicio Ingersoll–Rand autorizado más próximo.

Toda comunicación se deberá dirigir a la oficina o al distribuidor Ingersoll–Rand más próximo.

© Ingersoll–Rand Company 2000

Impreso en EE. UU.



**To Buy Ingersoll Rand Products Online visit [AirToolPro.com](http://AirToolPro.com)**

Brought to you by Zampini Industrial Group - Factory Authorized Distribution Since 1987 - 1-800-353-4676

## ETIQUETAS DE AVISO

### ⚠ AVISO

EL HACER CASO OMISO DE LOS AVISOS SIGUIENTES PODRÍA OCASIONAR LESIONES.

	<p><b>⚠ ADVERTENCIA</b></p> <p>Use siempre protección ocular cuando utilice esta herramienta o realice operaciones de mantenimiento en la misma.</p>
---	--

	<p><b>⚠ ADVERTENCIA</b></p> <p>Use siempre protección para los oídos cuando utilice esta herramienta.</p>
---	---

	<p><b>⚠ ADVERTENCIA</b></p> <p>Cortar siempre el suministro de aire y desconectar la manguera de suministro de aire antes de instalar, retirar o ajustar cualquier accesorio de esta herramienta, o antes de realizar cualquier operación de mantenimiento de la misma.</p>
---	---

	<p><b>⚠ ADVERTENCIA</b></p> <p>Las herramientas neumáticas pueden vibrar durante el uso. La vibración, los movimientos repetitivos o las posiciones incómodas podrían dañarle los brazos y las manos. En caso de incomodidad, sensación de hormigueo o dolor, dejar de usar la herramienta. Consultar al médico antes de volver a utilizarla.</p>
---	---

	<p><b>⚠ ADVERTENCIA</b></p> <p>No coger la herramienta por la manguera para levantarla.</p>
---	---

	<p><b>⚠ ADVERTENCIA</b></p> <p>No utilizar mangueras de aire y accesorios dañados, desgastados ni deteriorados.</p>
---	---

	<p><b>⚠ ADVERTENCIA</b></p> <p>Mantener una postura del cuerpo equilibrada y firme. No estirar demasiado los brazos al manejar la herramienta.</p>
---	--

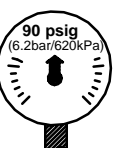
	<p><b>⚠ ADVERTENCIA</b></p> <p>Manejar la herramienta a una presión de aire máxima de 90 psig (6,2 bar/620 kPa).</p>
---	--

## AVISOS ESPECÍFICOS PARA AMOLADORA

- No use esta herramienta si la velocidad libre en vacío excede la indicada en la placa de identificación.
- Antes de montar una muela, y después de todas las reparaciones de herramienta y siempre que se proporcione una Amoladora para su uso, compruebe la velocidad en vacío de la Amoladora con un tacómetro para asegurarse de que su velocidad real a 90 psig (6,2 bar/620 kPa) no exceda las rpm estampadas o impresas en la placa de identificación. Las Amoladoras usadas en trabajos deberán ser examinadas similarmente como mínimo una vez en cada jornada de trabajo.
- Use siempre el Cubremuela Ingersoll–Rand suministrado con la Amoladora.
- No use una Amoladora sin el cubremuela recomendado. No use ninguna muela que tenga una velocidad de funcionamiento, tal y como aparece en el registro, menor que la velocidad en vacío de la Amoladora.
- Inspeccione todas las muelas antes de su montaje para ver si tienen grietas o roturas. No use una muela que esté rota o agrietada o dañada de cualquier otra forma. No use una muela que haya estado a remojo en agua o en cualquier otro líquido.
- Asegúrese que la muela esté bien puesta en el eje. La muela no debe estar muy floja ni muy apretada. No use aros reductores para adaptar una muela al eje a menos que éstos hayan sido suministrados o recomendados por el fabricante de muelas.
- Después de haber montado una rueda nueva, sujete la Amoladora bajo un banco de acero o dentro de un molde y hágala funcionar durante 60 segundos como mínimos. Asegúrese de que no haya nadie en el entorno de operación de muela. Si la muela es defectuosa, está mal montada o es del tamaño y velocidad incorrectas, normalmente fallará en este momento.
- Cuando inicie una muela en frío, aplíquela lentamente al trabajo hasta que se caliente gradualmente. Contacte la zona de trabajo suavemente, y evite golpes o exceso de presión.
- Cambie siempre un cubremuela dañado, torcido o muy desgastado. No use un cubremuela que haya experimentado un fallo de muela.
- Asegúrese que las bridas de muela sean de un diámetro mínimo de 1/3 de la muela y que estén libres de marcas, rebabas y bordes afilados. Use siempre las bridas de muela suministradas por el fabricante; no use nunca una brida casera o arandela normal.
- La apertura del cubremuela deberá estar orientada hacia afuera del operario. La parte inferior de la muela no deberá proyectarse fuera del cubremuela.
- Use siempre un distanciador entre cada brida de muela y muela. Los distanciadores deberán ser de un diámetro mínimo igual al de bridas de muela.
- No intente desmontar el regulador. El Regulador está disponible solamente como unidad y está garantizado por toda la vida útil de la herramienta, si no se abusa de él.



## AVISOS ESPECÍFICOS PARA AMOLADORA

**AVISO:** Combinaciones incorrectas de rueda de rectificación, protector de rueda y velocidad de herramienta puedan resultar en lesionamientos. Las combinaciones correctas se especifican a continuación:

Número de Pieza del Protector	Tipo de Rueda	Diámetro de Rueda in. (mm)	Grosor Máximo de Rueda in. (mm)	Velocidad Máxima (rpm)
61H-931A	1	3 (76)	1/2 (12,7)	15.000

### PARA PONER LA HERRAMIENTA EN SERVICIO

#### LUBRICACIÓN



Ingersoll-Rand N° .50



Ingersoll Rand N° .68

Utilice siempre un lubricador de aire comprimido con estas herramientas. Recomendamos la siguiente unidad de Filtro-Lubricador-Regulador:

EE. UU. - C28-04-FKG0-28

**Antes de poner la herramienta en marcha**, a menos que se haya puesto un lubricante de línea de aire comprimido, desconecte la manguera de aire e inyecte unos 2,5 cc de aceite Ingersoll-Rand N° .50 en la admisión de aire. Saque el Tapón de Cámara de Aceite de la Palanca de Mando y llene la cámara.

**Después de cada ocho horas de funcionamiento**, o como indique la experiencia, vuelva a llenar el suministro de aceite de la empuñadura.

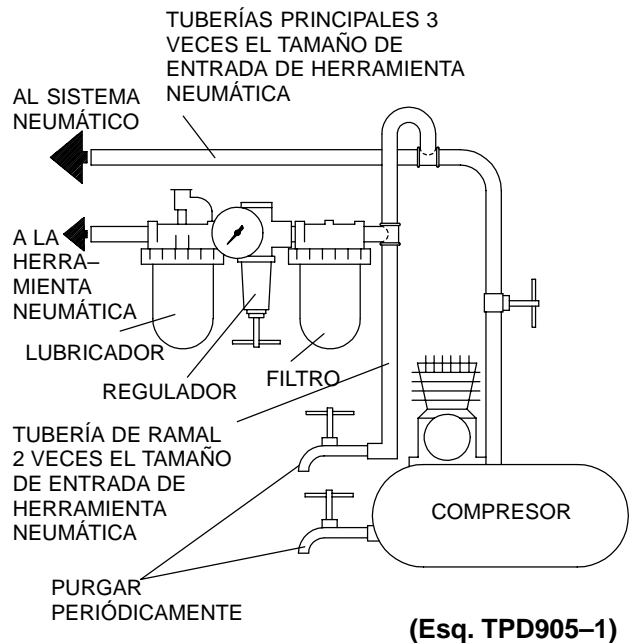

#### ESPECIFICACIONES

Modelo	Velocidad en vacío rpm	Husillo
61H120G4	12.000	Pinza Erickson 1/4 pulg.
61H150G4	15.000	Pinza Erickson 1/4 pulg.
61H120L6	12.000	Husillo 3/8"-24
61H150L6	15.000	Husillo 3/8"-24
61H120H63	12.000	Husillo 3/8"-24, Cubremuela 3 pulg.
61H120H64	12.000	Husillo 3/8"-24, Cubremuela 4 pulg.
61H150H63	15.000	Husillo 3/8"-24, Cubremuela 3 pulg.

# MANUAL DE FUNCIONAMENTO E MANUTENÇÃO PARA ESMERILADORAS PNEUMÁTICAS HORIZONTAIS SÉRIES 61H

## AVISO

As Esmeriladoras Pneumáticas Horizontais Séries 61H são concebidas para esmerilamento de trabalho pesado e áreas confinadas tais como moldes pequenos ou dentro de moldes grandes. A Ingersoll-Rand não é responsável por modificações, feitas pelo cliente em ferramentas, nas quais a Ingersoll-Rand não tenha sido consultada.

## ⚠️ ADVERTÊNCIA

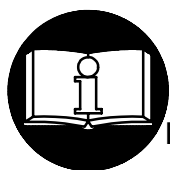

**INFORMAÇÃO DE SEGURANÇA IMPORTANTE EM ANEXO.  
LEIA ESTE MANUAL ANTES DE OPERAR A FERRAMENTA.  
É DA RESPONSABILIDADE DO EMPREGADOR COLOCAR A INFORMAÇÃO  
DESTE MANUAL NAS MÃOS DO OPERADOR.**

**O NÃO CUMPRIMENTO DAS SEGUINTE ADVERTÊNCIAS PODE RESULTAR EM FERIMENTOS.**

### COLOCANDO A FERRAMENTA EM FUNCIONAMENTO

- Sempre opere, inspecione e mantenha esta ferramenta de acordo com o Código de Segurança do Instituto Americano de Padrões Nacionais para Ferramentas Pneumáticas Portáteis (ANSI B186.1).
- Para segurança, máximo desempenho e máxima durabilidade das peças, opere esta ferramenta com uma pressão de ar máxima de 6,2 bar/620 kPa (90 psig) na entrada da mangueira de alimentação de ar com diâmetro interno de 13mm (1/2").
- Desligue sempre a alimentação de ar e desconecte a mangueira de alimentação de ar antes de instalar, remover ou ajustar qualquer acessório nesta ferramenta, ou antes de executar qualquer serviço de manutenção nesta ferramenta.
- Não use mangueiras de ar ou adaptadores danificados, gastos ou deteriorados.
- Certifique-se de que todas as mangueiras e adaptadores sejam do tamanho correcto e estejam apertados com firmeza. Veja o Desenho TPD905-1 para um arranjo típico de tubagem.
- Use sempre ar seco e limpo com pressão máxima de 6,2 bar/620 kPa (90 psig). Pó, fumos corrosivos e/ou humidade excessiva podem arruinar o motor de uma ferramenta pneumática.
- Não lubrifique as ferramentas com líquidos inflamáveis ou voláteis tais como querosene, diesel ou combustível de jactos.

- Não remova nenhum rótulo. Reponha qualquer rótulo danificado.

### USANDO A FERRAMENTA

- Use sempre óculos de protecção quando estiver operando ou executando serviço de manutenção nesta ferramenta.
- Use sempre protecção contra ruído ao operar esta ferramenta.
- Mantenha as mãos, partes do vestuário soltas e cabelos compridos afastados da extremidade em rotação.
- Antecipe e esteja alerta a mudanças repentinas no movimento quando ligar e operar qualquer ferramenta motorizada.
- Mantenha a posição do corpo equilibrada e firme. Não exagere quando operar esta ferramenta. Torques de reacção elevados podem ocorrer na ou abaixo da pressão de ar recomendada.
- Os acessórios da ferramenta podem continuar a girar brevemente após a pressão ter sido aliviada.
- Ferramentas accionadas pneumáticamente podem vibrar em uso. Vibração, movimentos repetitivos ou posições desconfortáveis podem ser prejudiciais às mãos e aos braços. Pare de usar a ferramenta caso ocorra algum desconforto, sensação de formigueiro ou dor. Procure assistência médica antes de retornar ao trabalho.
- Use acessórios recomendados pela Ingersoll-Rand.
- Esta Ferramenta não foi concebida para trabalhos em atmosferas explosivas.
- Esta Ferramenta não está isolada contra choques eléctricos.

## AVISO

O uso de peças de substituição que não sejam genuinamente da Ingersoll-Rand podem resultar em riscos de segurança, diminuição do desempenho da ferramenta, aumento da necessidade de manutenção e pode invalidar todas as garantias.

As reparações devem ser feitas somente por pessoal treinado autorizado. Consulte o Centro de Serviços da Ingersoll-Rand mais próximo.

Envie Todos os Comunicados Para o Distribuidor ou Escritório da Ingersoll-Rand Mais Próximo.

© Ingersoll-Rand Company 2000

Impresso nos E.U.A.



**To Buy Ingersoll Rand Products Online visit [AirToolPro.com](http://AirToolPro.com)**

Brought to you by Zampini Industrial Group - Factory Authorized Distribution Since 1987 - 1-800-353-4676

# IDENTIFICAÇÃO DO RÓTULO DE ADVERTÊNCIA

## ▲ ADVERTÊNCIA

O NÃO CUMPRIMENTO DAS SEGUINTE ADVERTÊNCIAS PODE RESULTAR EM FERIMENTOS.

	<p><b>▲ ADVERTÊNCIA</b></p> <p>Use sempre óculos de protecção quando estiver operando ou executando algum serviço de manutenção nesta ferramenta.</p>
---	---

	<p><b>▲ ADVERTÊNCIA</b></p> <p>Use sempre protecção contra o ruído ao operar esta ferramenta.</p>
---	---

	<p><b>▲ ADVERTÊNCIA</b></p> <p>Desligue sempre a alimentação de ar e desconecte a mangueira de alimentação de ar antes de instalar, remover ou ajustar qualquer acessório nesta ferramenta, ou antes de executar algum serviço de manutenção nesta ferramenta.</p>
---	--

	<p><b>▲ ADVERTÊNCIA</b></p> <p>Ferramentas accionadas pneumáticamente podem vibrar em uso. Vibração, movimentos repetitivos ou posições desconfortáveis podem ser prejudiciais às mãos e aos braços. Pare de usar a ferramenta caso ocorra algum desconforto, sensação de formigamento ou dor. Procure assistência médica antes de retornar ao trabalho.</p>
---	--

	<p><b>▲ ADVERTÊNCIA</b></p> <p>Não carregue a ferramenta segurando na mangueira.</p>
---	--

	<p><b>▲ ADVERTÊNCIA</b></p> <p>Não use mangueiras de ar ou adaptadores danificados, gastos ou deteriorados.</p>
---	---

	<p><b>▲ ADVERTÊNCIA</b></p> <p>Mantenha a posição do corpo equilibrada e firme. Não exagere quando operar esta ferramenta. Torques de reacção elevados podem ocorrer sob a pressão de ar recomendada.</p>
---	---

	<p><b>▲ ADVERTÊNCIA</b></p> <p>Opere com pressão do ar Máxima de 90–100 psig (6,2–6,9 bar).</p>
---	---

## ADVERTÊNCIAS ESPECÍFICAS SOBRE A ESMERILADORA

- Não use esta ferramenta se a velocidade livre total exceder a rpm indicada na placa de identificação.
- Antes de montar o disco, depois de qualquer reparação de ferramenta ou quando se pretende que uma Esmeriladora seja colocada em funcionamento, verifique a velocidade livre da Esmeriladora com um tacometro para se certificar de que a sua velocidade real a 6,2 bar/620kPa (90 psig) não exceda a rpm selada ou impressa na placa de identificação. As Esmeriladoras em funcionamento devem ser similarmente verificadas pelo menos uma vez em cada turno.
- Use sempre o Protector do Disco da Ingersoll–Rand fornecido com a Esmeriladora
- Não use uma Esmeriladora sem um protector de disco recomendado. Não use qualquer disco no qual a velocidade de operação listada no mata–borrão seja inferior à velocidade livre real da Esmeriladora.
- Verifique todas os discos de esmerilamento para ver se há lascas ou rachaduras antes da montagem. Não use um disco que esteja lascado ou rachado ou de alguma maneira danificado. Não use um disco que tenha sido encharcado com água ou qualquer outro líquido.
- Certifique–se de que o disco se encaixa adequadamente na árvore de montagem. O disco não deve se adaptar muito apertado nem muito frouxo. Os discos do furo apenas devem ter uma folga diametral de no máximo 0,17mm (0,007”). Não use rolamentos redutores para adaptar um disco na árvore de montagem a não ser que tais rolamentos tenham sido fornecidos ou recomendados pelo fabricante do disco.
- Depois de montar um novo disco, segure a Esmeriladora sob uma bancada de aço ou dentro de uma moldagem e coloque–a em funcionamento por 60 segundos. Verifique se não há ninguém dentro do plano de operação. Se o disco estiver com algum defeito, inadequadamente montado ou se for do tamanho errado ou tiver velocidade incorrecta, este é o momento em que ele normalmente falhará.
- Quando iniciar um trabalho com um disco frio, ponha–o a trabalhar lentamente até que o discor aqueça gradualmente Faça um contacto suave com o local a ser trabalhado e evite de executar qualquer ação de batimento ou pressão excessiva.
- Reponha um protector do disco sempre que estiver danificado, torto ou severamente gasto. Não use um protector do disco que tenha sido sujeito a uma falha do disco.
- Certifique–se de que as flanges da roda sejam pelo menos 1/3 do diâmetro do disco de esmerilamento, livre de cortes, arestas e extremidades afiadas. Use sempre flanges do disco fornecidas pelo fabricante. Nunca use uma flange provisória ou uma anilha plana. Aperte bem a Porca da Flange.
- A abertura do protector deve estar afastada do operador. O fundo do disco não deve se estender para fora do protector.

## ADVERTÊNCIAS ESPECÍFICAS DA ESMERILADORA

- Sempre use um mata-borrão de disco entre cada flange do disco e o disco. Os mata-borrões devem ser pelo menos do mesmo tamanho em diâmetro que as flanges dos discos.
- Não tente desmontar o Controlador. O Controlador é disponível apenas como uma unidade e é garantido pela vida útil da ferramenta se não houver abuso na sua utilização.

**ADVERTÊNCIA:** Combinações incorrectas de disco de esmerilamento, protector do disco e velocidade da ferramenta pode resultar em ferimento.

As combinações correctas estão especificadas abaixo:

Número de Peça do Protector	Tipo do Disco	Diâmetro do Disco mm (pol.)	Espessura Máxima do Disco mm (pol.)	Velocidade Máxima rpm
61H-931A	1	76 (3)	12,7 (1/2)	15.000

## COLOCANDO A FERRAMENTA EM FUNCIONAMENTO

### LUBRIFICAÇÃO



Ingersoll-Rand No. 50      Ingersoll-Rand No. 28

Use sempre um lubrificador de ar de linha com estas ferramentas. Nós recomendamos a seguinte Unidade Filtro-Lubrificador-Regulador:

E.U.A. - C28-04-FKG0-28

**Antes de ligar a ferramenta**, a menos que um lubrificador de linha esteja sendo usado, desconecte a mangueira de ar em injecte aproximadamente 2,5 cc de Óleo Ingersoll-Rand No. 50 na entrada de ar. Remova o Bujão do Câmara de Óleo do Punho Regulador de Pressão e encha a câmara.

**Depois de cada oito horas de operação**, ou como a experiência indicar, reponha a alimentação de óleo no Punho.

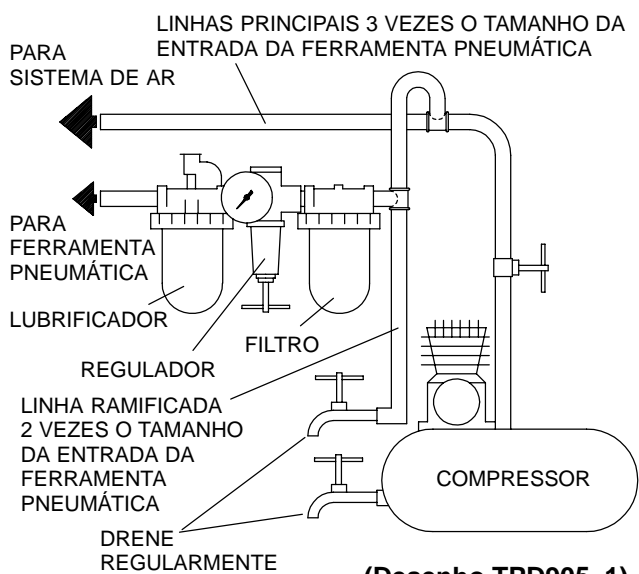

## ESPECIFICAÇÕES

Modelo	Velocidade Livre rpm	Fuso
61H120G4	12.000	Engaste Erickson de 1/4"
61H150G4	15.000	Engaste Erickson de 1/4"
61H120L6	12.000	Fuso de 3/8-24
61H150L6	15.000	Fuso de 5/8-11
61H120H63	12.000	Fuso de 3/8-24, Protector de 3"
61H120H64	12.000	Fuso de 3/8-24, Protector de 4"
61H150H63	15.000	Fuso de 3/8-24, Protector de 3"

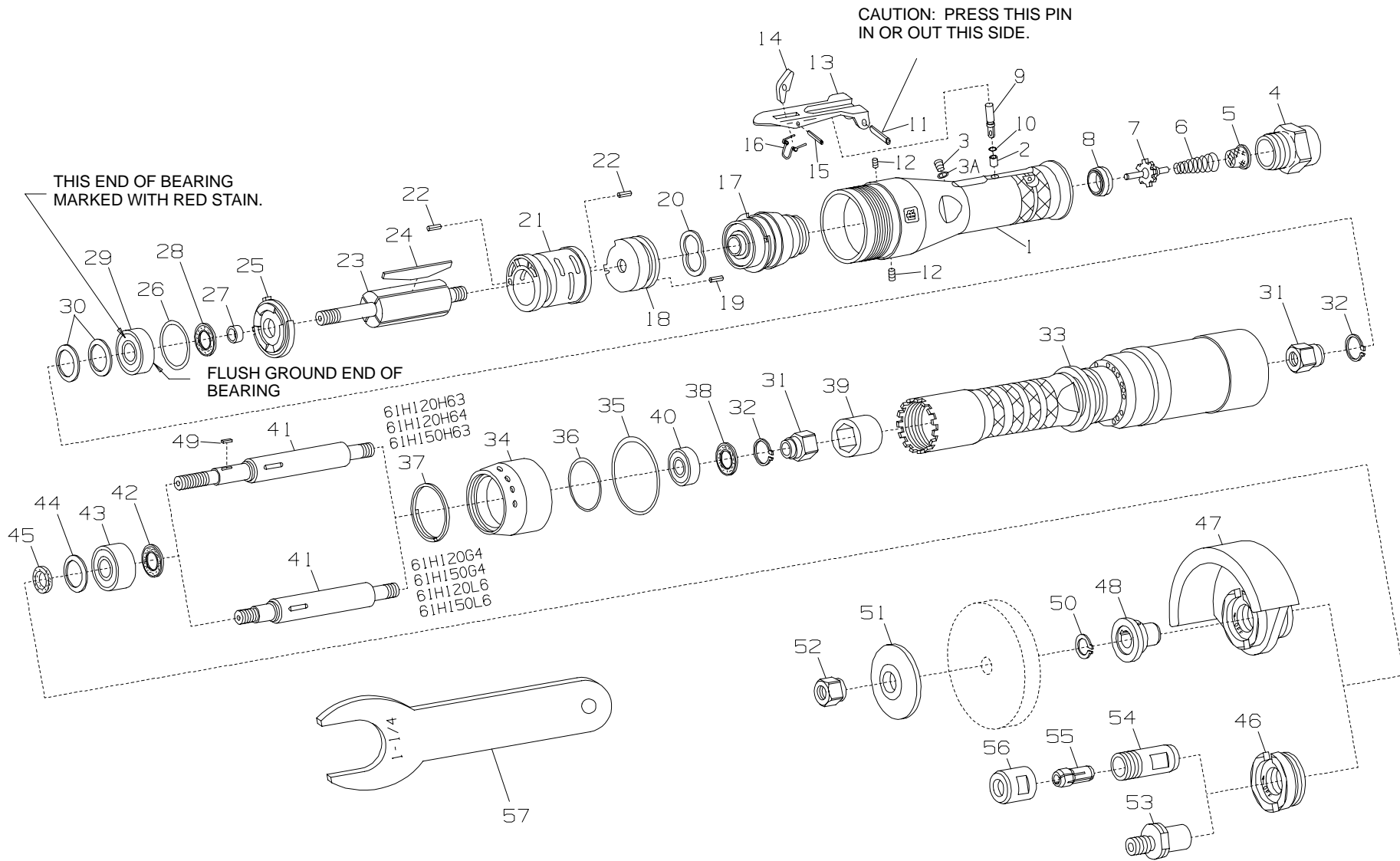

(Dwg. TPA1222-2)



PART NUMBER FOR ORDERING

PART NUMBER FOR ORDERING

14

1	Throttle Handle Assembly for 61H120 models ending in -EU . . . . . for all other 61H120 models . . . . . for 61H150 models ending in -EU . . . . . for all other 61H150 models . . . . .	61H120-EU-A160 61H120-A160 61H150-EU-A160 61H150-A160	25	Front End Plate Assembly . . . . .	61H-A11
2	Throttle Plunger Bushing . . . . .	AG210-91	26	Front End Plate Seal . . . . .	AF120-294
3	Oil Chamber Plug . . . . .	D92-227	27	Rotor Spacer Assembly . . . . .	61H-A65
3A	Washer . . . . .	R3-92A	28	Seal Cup Assembly . . . . .	61H-A32
4	Inlet Bushing . . . . .	434-565	• 29	Front Rotor Bearing . . . . .	61H-24
5	Air Strainer Screen . . . . .	61H-61	30	Motor Clamp Washer (2) . . . . .	61H-207
6	Throttle Valve Spring . . . . .	DG230-51	31	Bearing Nut Assembly (2) . . . . .	61H-A85
7	Throttle Valve . . . . .	DG230-302	32	Bearing Nut Retainer . . . . .	R4800-119
8	Throttle Valve Seat . . . . .	DG230-303	33	Arbor Housing for models ending in G4-EU . . . . . for models ending in L6-EU . . . . . for models ending in H63-EU . . . . . for all other models . . . . .	61H-A40-EU-G4 61H-A40-EU-L6 61H-A40-EU-H63 61H-A40
9	Throttle Plunger Assembly . . . . .	61H-A152	*	Warning Label (included with 61H-A40) . .	WARNING-4-99
10	Throttle Plunger Stop . . . . .	8SL-259	*	Warning Label (for all models ending in -EU) . . . . .	WARNING-4-99
11	Throttle Lever Pin . . . . .	502B-120	34	Exhaust Deflector . . . . .	61H-23
12	Rear End Plate Retaining Screw (2) . . . . .	61H-669	35	Rear Deflector Seal . . . . .	AF160-291Z
13	Throttle Lever Assembly . . . . .	61H-A400	36	Front Deflector Seal . . . . .	M0V010AA-379
14	Throttle Lever Lock Kit . . . . .	61H-K402	37	Deflector Retaining Ring . . . . .	61H-203
15	Lever Lock Pin . . . . .	61H-120	38	Seal Cup Assembly . . . . .	61H-A32
16	Lever Lock Spring . . . . .	61H-405	39	Arbor Coupling . . . . .	61H-304
17	Controller Assembly for 61H120 . . . . . for 61H150 . . . . .	61H120-A424 61H150-A424	40	Rear Arbor Bearing . . . . .	WFS182-22
• 18	Rear End Plate Assembly . . . . .	61H-A12	41	Arbor Assembly for 61H120G4, 61H150G4, 61H120L6 or 61H150L6 . . . . . for 61H120H63, 61H120H64 or 61H150H63 . . . . .	61H-A4-L6 61H-A4-H6
19	Wiper Plate Alignment Pin . . . . .	R100BRC0-667A	42	Seal Cup Assembly . . . . .	61H-A32
20	Rear Rotor Bearing Washer . . . . .	R43F-278	• 43	Wheel End Bearing . . . . .	61H-33
21	Cylinder Assembly . . . . .	61H-A3	44	Bearing Clamp Washer . . . . .	61H-207
22	Cylinder Dowel Pin (2) . . . . .	JC3350-538			
23	Rotor . . . . .	61H-53			
• 24	Vane Packet (set of 4 Vanes) . . . . .	61H-42-4			

MAINTENANCE SECTION

\* Not illustrated.

• To keep downtime to a minimum, it is desirable to have on hand certain repair parts. We recommend that you stock one (pair or set) of each part indicated by a bullet (•) for every four tools in service.

To Buy Ingersoll Rand Products Online visit [AirToolPro.com](http://AirToolPro.com)

Brought to you by Zampini Industrial Group - Factory Authorized Distribution Since 1987 - 1-800-353-4676

PART NUMBER FOR ORDERING

PART NUMBER FOR ORDERING

45	Dust Washer . . . . .	61H-35	54	Collet Body . . . . .	DG220-290
▲ 46	Wheel End Bearing Cap (for Model 61H120G4, 61H120L6, 61H150G4 or 61H150L6) . . . . .	61H-K19	55	Collet for 6 mm (-EU) . . . . .	G160HD-700-6mm
47	Wheel Guard for Model 61H120H63 or 61H150H63 (3" diameter) . . . . .	61H-931A		for 1/4" diameter shank accessories . . . . .	G160HD-700-1/4
	for Model 61H120H64 (4" diameter) . . . . .	61H-941		for 3/8" diameter shank accessories . . . . .	DG120-700-G6
48	Inner Wheel Flange (for Model 61H120H63, 61H120H64 or 61H150H63) .	61H-86-4H6	56	Collet Nut . . . . .	DG121-700-M8 DG120-699A
49	Inner Wheel Flange Key (for Model 61H120H63, 61H120H64 or 61H150H63) .	61H-70	*	Collet Nut Wrench (for Model 61H120G4 or 61H150G4) . . . . .	DG120-69
50	Inner Wheel Flange Retainer (for Model 61H120H63, 61H120H64 or 61H150H63) .	61H-119	*	Collet Body Wrench (for Model 61H120G4 or 61H150G4) . . . . .	DG10-69
51	Outer Wheel Flange for Model 61H120H64 . . . . .	61H-16-4H6	#	Collet Assembly (for Model 61H120H63, 61H120H64 or 61H150H63) .	R0-A390-1/4
	for Model 61H120H63 and 61H150H63 . . . . .	DEG31-16	*	Collet Body . . . . .	R0-390-1/4
52	Wheel Flange Nut (for Model 61H120H63, 61H120H64 or 61H150H63) .	23-697	■	Collet Sleeve . . . . .	R0-391-1/4
53	Cone Wheel Adapter (for Model 61H120L6 or 61H150L6) . . . . .	DG220-104-L6	57	Controller Wrench . . . . .	R15-169
*	Cone Wheel Adapter Wrench . . . . .	DG20-69	*	Tune-up Kit (includes illustrated items 5, 6, 7, 8, 10, 12[2], 20, 24, 26, 28, 35, 36, 38, 42, 45, 49 and 50) . . . . .	61H-TK1
	Collet Assembly (for Model 61H120G4 or 61H150G4) for 1/4" diameter shank accessories . . . . .	DG220-A290-G4			
	for 3/8" diameter shank accessories . . . . .	DG220-A290-G6			
	for 8 mm diameter shank accessories . . . . .	DG220-A290-M8			

\* Not illustrated.

▲ This Wheel End Bearing Cap can be used with Type 1 wheels for internal grinding only, in accordance with ANSI B186.1 "Safety Code for Portable Air Tools".

# When ordering this Collet Assembly (Part No. R0-A390-1/4) for use with Model 61H120H63, 61H120H64 or 61H150H63 Grinder, a Wheel End Bearing Cap (46) and Dust Washer (45) must also be ordered.

■ A Controller Wrench (57) is not furnished with the tool and must be ordered separately. This Wrench is required to service the motor and remove or replace the Controller Assembly (17).

## MAINTENANCE SECTION

### WARNING

Always wear eye protection when operating or performing maintenance on this tool.

Always turn off air supply and disconnect air supply hose before installing, removing or adjusting any accessory on this tool, or before performing any maintenance on this tool.

### LUBRICATION

Each time the Series 61H Grinder is disassembled for maintenance, repair or replacement of parts, lubricate the tool as follows:

1. Apply a coating of Ingersoll–Rand No. 68 Grease to the inner surface of the Arbor Coupling (39).
2. Fill the oil reservoir in the handle with Ingersoll–Rand No. 50 Oil. Inject approximately 2.5 cc of oil into the air inlet before attaching the air hose. Remove the Oil Chamber Plug (3) and fill the oil chamber.
3. When installing a new Seal Cup Assembly (28, 38, or 42) or a new Dust Washer (45), impregnate the new seal or washer with Ingersoll–Rand No. 50 Oil before installation.

### DISASSEMBLY

#### General Instructions

1. Do not disassemble the tool any further than necessary to replace or repair damaged parts.
2. Whenever grasping a tool or part in a vise, always use leather–covered or copper–covered vise jaws to protect the surface of the part and help prevent distortion. This is particularly true of threaded members and housings.
3. Do not remove any part which is a press fit in or on a subassembly unless the removal of that part is necessary for repairs or replacement.
4. Do not disassemble the tool unless you have a complete set of new gaskets and O–rings for replacement.

#### Disassembly of the Tool

1. Clamp the handle of the Grinder horizontally in leather–covered or copper–covered vise jaws.
2. **For Models 61H120H63, 61H120H64 and 61H150H63**, proceed as follows:
  - a. Insert a sprag pin into one of the radial holes in the Inner Wheel Flange (48) and using a wrench, remove the Wheel Flange Nut (52).
  - b. Remove the Outer Wheel Flange (51) and the grinding wheel.

- c. Using snap ring pliers, remove the Inner Wheel Flange Retainer (50) and slide the Inner Wheel Flange off the Arbor (41) being careful not to lose the Inner Wheel Flange Key (49).

**For Models 61H120G4 and 61H150G4**, using a wrench on the flats of the Collet Body (54) and the flats on the Collet Nut (56), unscrew the Collet Nut and remove the Collet (55).

**For Models 61H120L6 and 61H150L6**, unscrew and remove the cone wheel.

### NOTICE

**The Wheel Guard (47) has left–hand threads.**

3. **For Models 61H120H63, 61H120H64 and 61H150H63**, using a wrench on the hub of the Wheel Guard, unscrew and remove the Wheel Guard and Bearing Clamp Washer (44).

### NOTICE

**The Wheel End Bearing Cap (46) has left–hand threads.**

**For all other models**, using a wrench, unscrew and remove the Wheel End Bearing Cap and Bearing Clamp Washer (44).

4. Grasping the Arbor (41), Collet Body (54) or Cone Wheel Adapter (53), pull the assembled Arbor from the Arbor Housing (33).
5. **For Models 61H120G4 and 61H150G4**, using one wrench on the flats of the Collet Body and another on the flats of the Arbor, unscrew and remove the Collet Body.  
**For Models 61H120L6 and 61H150L6**, using one wrench on the flats of the Cone Wheel Adapter and another on the flats of the Arbor, unscrew and remove the Cone Wheel Adapter.
6. If the Dust Washer (45) must be replaced, use a pointed probe to pick the Washer out of the Wheel End Bearing Cap or Wheel Guard.
7. Slide the Wheel End Bearing (43) off the Arbor and pull the Seal Cup Assembly (42) off the Arbor if it needs replacement.
8. Using a wrench on the flats of the Arbor and another on the flats of the Bearing Nut Assembly (31), unscrew and remove the Bearing Nut Assembly.
9. If the Seal Cup Assembly (38) requires replacement, pull it off the Bearing Nut Assembly.
10. Slide the Rear Arbor Bearing (40) off the Arbor.
11. If the Arbor Coupling (39) remained in the Arbor Housing when the Arbor was removed, strike the castellated end of the Housing against a block of wood to free the Coupling.



## MAINTENANCE SECTION

- Using a thin blade screwdriver, spiral the Deflector Retaining Ring (37) out of the annular groove on the Arbor Housing.
- Slide the Exhaust Deflector (34), Front Deflector Seal (36) and Rear Deflector Seal (35) off the castellated end of the Arbor Housing.

### Disassembly of the Motor

- Using a 5/64" hex wrench, unscrew and remove the two Rear End Plate Retaining Screws (12).
- Using a wrench on the flats of the Arbor Housing and another on the flats of the Throttle Handle Assembly (1), unscrew and remove the Arbor Housing. Pull the assembled motor out of the Arbor Housing. Remove the two Motor Clamp Washers (30) from the front of the motor or from the inside of the Arbor Housing.
- Clamp the Bearing Nut Assembly (31) at the front of the motor in leather-covered or copper-covered vise jaws with the Controller Assembly (17) upward.
- Using the Controller Wrench (57) on the flats of the Controller Assembly, unscrew and remove the Controller Assembly.
- Lift the Rear Rotor Bearing Washer (20), Rear End Plate Assembly (18) and Cylinder Assembly (21) off the Rotor (23).
- Remove the Vanes (24) from the Rotor.
- Remove the Rotor from the vise. Using leather-covered or copper-covered vise jaws, carefully grasp the vane portion of the Rotor in the vise with the Front Rotor Bearing (29) upward.
- Using a wrench, unscrew and remove the Bearing Nut Assembly from the Rotor.
- Pull the Front Rotor Bearing (29), Rotor Spacer Assembly (27) and Front End Plate Assembly (25) off the hub of the Rotor. If the Seal Cup Assembly (28) must be replaced, pull the Assembly off the Rotor Spacer.

### Disassembly of the Throttle

- Using one wrench on the Throttle Handle Assembly flats and another wrench on the Inlet Bushing (4), unscrew the Inlet Bushing and remove the Air Strainer Screen (5), Throttle Valve Spring (6) and the Throttle Valve (7) from the handle.
- If the Throttle Valve Seat (8) must be removed, insert a hooked rod through the central opening in the Seat and, catching the underside of the Seat, pull the Seat from the handle.

### CAUTION

The Throttle Lever Pin must be pressed from the throttle handle in a specific direction. Refer to the Drawing TPA1222-2. Failure to remove the Pin correctly will distort or damage the throttle handle.

### NOTICE

The pin hole in one side of the Lever is larger than the other to facilitate removal and installation. Removing the Pin will allow the Lever Lock Spring (16) and Lever Lock (14) to be removed.

- To remove the Throttle Lever Assembly (13), press the Throttle Lever Pin (11) out of the throttle handle.
- Lift off the Throttle Lever Assembly.
- If it is necessary to disassemble Throttle Lever Assembly (13), use a pin punch and hammer to drive the Lever Lock Pin (15) out the side of the Lever as shown in the Drawing TPA1222-2.
- To remove the Throttle Plunger Assembly (9), grasp the Plunger in copper-covered vise jaws and with a twisting action, pull the handle off the Plunger over the Throttle Plunger Stop (10).
- To remove the Throttle Plunger Bushing (2), proceed as follows:
  - Grasp the flats of a 1/4"-20 tap in copper-covered vise jaws with the thread cutting end upward.
  - Thread the Bushing (with the handle) onto the tap.

### CAUTION

Do not heat the handle to remove the Bushing. Heat may cause damage to factory installed internal components.

- Using a plastic hammer, sharply rap the handle several times in the bushing area to loosen the retaining compound. Pull the handle with a twisting motion from the Bushing.

## ASSEMBLY

### General Instructions

- Always press on the **inner** ring of a ball-type bearing when installing the bearing on a shaft.
- Always press on the **outer** ring of a ball-type bearing when pressing the bearing into a bearing recess.
- Whenever grasping a tool or part in a vise, always use leather-covered or copper-covered vise jaws. Take extra care with threaded parts and housings.
- Always clean every part and wipe every part with a thin film of oil before installation.
- Apply a film of O-ring lubricant to all O-rings before final assembly.

## MAINTENANCE SECTION

### Assembly of the Throttle

1. If the Throttle Plunger Bushing (2) was removed, proceed as follows:
  - a. Insert the Throttle Plunger Bushing into the Throttle Handle Assembly (1) to a depth approximately one-half the length of the Bushing.
  - b. Put a few drops of M. I. Hernon No. 822 sealant completely around the outside surface of the Bushing.
  - c. Rotate the Bushing approximately 180° to make certain the sealant makes complete contact around the outside of the Bushing.
  - d. Push the Bushing into the handle until it bottoms against the shoulder inside the handle.
  - e. Allow the sealant to cure for eight hours at room temperature.
2. Install the Throttle Plunger Stop (10) in the annular groove in the Throttle Plunger (9).

### NOTICE

**Make certain the Throttle Plunger Stop enters the tool air flow chamber.**

3. With the Stop lubricated and using a turning motion, insert the assembled Throttle Plunger, Seal end leading, into the Bushing.
4. If the Throttle Lever Assembly (13) was disassembled, proceed as follows:
  - a. Using a No. 43 drill or a piece of metal rod slightly under 0.090" diameter as a slave pin, position the Lever Lock (14) and Lever Lock Spring (16) in the Throttle Lever Assembly (13). Make certain the ends of the Spring are toward the tool inlet and the narrow end of the Lever Lock is toward the handle.
  - b. Check the functioning of the Lever Lock. If the Lock flattens against the Lever when the top portion of the Lock is pushed forward and returns to vertical when the Lock is released, it is assembled properly.
  - c. While controlling the slave pin, start the Lever Lock Pin (15) into the side of the Lever as shown in the Drawing TPA1222-2.
  - d. While maintaining control of the slave pin, and using a hammer, tap the Lever Pin into position.

### CAUTION

**The Throttle Lever Pin must be pressed into the throttle handle in a specific direction. Refer to the Drawing TPA1222-2. Failure to install the Pin correctly will distort or damage the throttle handle.**

5. Position the Throttle Lever Assembly (13) on the Throttle Handle Assembly and press the Throttle Lever Pin (11) into position securing the Lever Assembly to the handle.
6. If the Throttle Valve Seat (8) was removed, use a flat-faced rod 3/4" (19 mm) in diameter by 4" (100 mm) long to push the Valve Seat into the handle until it seats.
7. Rotate the Throttle Plunger Assembly until the hole in the Plunger aligns dead center with the hole in the Throttle Valve Seat.
8. Using needle nose pliers to hold the short stem of the Throttle Valve (7), install the Valve inserting the long stem end through the hole in the Throttle Valve Seat and Throttle Plunger.
9. Install the Throttle Valve Spring (6), small end first, over the short stem of the Throttle Valve.
10. Insert the Air Strainer Screen (5), closed end leading, into the large end of the Valve Spring.
11. Install the Inlet Bushing (4) and tighten it between 74 and 100 ft-lb (100 and 135 Nm) torque.

### Assembly of the Motor

1. Clamp the large body of the Rotor (23) in leather-covered or copper-covered vise jaws with the longer spindle shaft upward.
2. Apply a small drop of a suitable thread-locking compound to the bottom of the O-ring groove at each of the four areas shown in Dwg. TPD1083 of the Front End Plate Assembly (25).

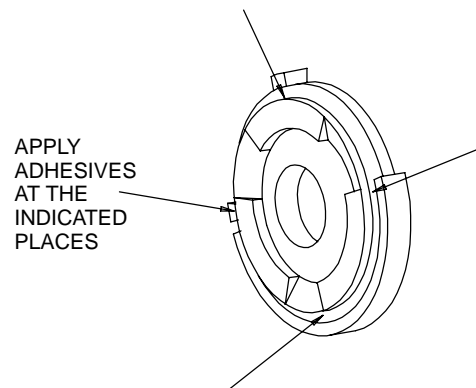

GLUE POINTS FOR 61H-A11 END PLATE ASSEMBLY

(Dwg. TPD1083)

3. Place the Front End Plate Seal (26) on the end plate hub and lightly press the Seal against the adhesive at the four contact points to bond the Seal to the End Plate.
4. Install the End Plate Assembly, Seal end trailing, over the shaft of the Rotor.

## MAINTENANCE SECTION

5. Using finger pressure, press the Seal Cup Assembly (28), felt end trailing, onto the Rotor Spacer (27) until the felt seal cup is flush with one end of the Spacer. Impregnate the felt with Ingersoll-Rand No. 50 Oil.
6. Install the Spacer, Seal Cup trailing, over the shaft of the Rotor. Make certain the Spacer enters the central opening of the Front End Plate and the Seal Cup Assembly enters the recess in the End Plate.
7. Install the Front Rotor Bearing, red stained end trailing, over the shaft of the Rotor.
8. If the Bearing Nut Retainers (32) were removed from the Bearing Nut Assembly (31), use snap ring pliers to install the Retainers on the Nuts.
9. Thread the Nut onto the shaft of the Rotor, Retainer end leading, and tighten the Nut between 14 and 19 ft-lb (19 to 26 Nm) torque.
10. Remove the Rotor from the vise and after turning it end for end, clamp the copper-covered vise jaws on the flats of the Bearing Nut with the unassembled rotor shaft upward.
11. Wipe each Vane (24) with a light film of oil and place a Vane in each slot in the Rotor.
12. One end of the Cylinder Assembly (21) has three ports while the other end has one. With the end having three ports toward the Front End Plate, install the Cylinder Assembly over the Rotor. Make certain the Cylinder Dowel Pin (22) at that end enters the small notch in the End Plate.
13. Install the Rear Rotor Bearing Washer (20) into the counterbore of the Rear End Plate Assembly (18).
14. Insert the Controller Assembly (17), bearing end leading, into the rear end plate counterbore against the Bearing Washer. Make certain the Wiper Plate Alignment Pin (19) enters the slot in the brass wiper plate of the Controller Assembly.
15. With the Rear End Plate Assembly leading, thread the Controller Assembly onto the shaft of the Rotor. Using the Controller Wrench (57), tighten the Controller Assembly between 8 and 10 ft-lb (10.5 and 13.5 Nm) torque.
3. Thread the Throttle Handle Assembly (1) into the assembled Arbor Housing and tighten the joint between 74 and 100 ft-lb (100 and 135 Nm) torque.
4. Install the two Rear End Plate Retaining Screws (12) flush with the handle surface or one thread below flush. If the Screws protrude above the handle surface, the Rear End Plate Assembly (18) is not properly engaged and is out of position.
5. Install the Rear Exhaust Deflector Seal (35) in the internal groove at the large end of the Exhaust Deflector (34).
6. Install the Front Deflector Seal (36) on the hub of the Arbor Housing adjacent to the wrench flats.
7. Slide the Exhaust Deflector onto the Arbor Housing and, using a thin blade screwdriver, spiral the Deflector Retaining Ring (37) into the groove ahead of the Deflector.
8. Using finger pressure, press the Seal Cup Assembly (38), felt end trailing, onto the small end of the Bearing Nut Assembly (31) until the felt seal cup is flush with the end of the Nut. Impregnate the felt with Ingersoll-Rand No. 50 Oil.
9. Push the Rear Arbor Bearing (40) onto the threaded hub farthest from the wrench flats on the Arbor Assembly (41).
10. Thread the assembled Bearing Nut Assembly/Seal Cup Assembly onto the Arbor with the Seal Cup toward the Bearing. Tighten the Nut between 14 and 19 ft-lb (19 and 26 Nm) torque.
11. Position the Seal Cup Assembly (42), felt end trailing, onto the Arbor near the wrench flats. Use the Wheel End Bearing (43) to push the Seal Cup Assembly onto the Arbor until the Bearing seats. Remove the Bearing and impregnate the felt with Ingersoll-Rand No. 50 Oil.
12. **For Models 61H120H63, 61H120H64 and 61H150H63**, proceed as follows:
  - a. Apply 1 cc of Ingersoll-Rand No. 68 Grease to the inside surfaces of the Arbor Coupling (39) and install the Coupling on the Bearing Nut at the motor end of the Arbor.
  - b. Insert the assembled Arbor, Coupling end first, into the Arbor Housing, making certain the Coupling engages the Bearing Nut on the Rotor.
  - c. Install the Wheel End Bearing (43) and Bearing Clamp Washer (44), concave end leading, onto the Arbor.
  - d. If the Dust Washer (45) was removed from the inside of the Wheel Guard (47), install a new Washer and impregnate it with Ingersoll-Rand No. 50 Oil.

### Assembly of the Tool

1. Drop the two Motor Clamp Washers (30), concave side trailing, into the large end of the Arbor Housing (33).
2. Remove the assembled motor from the vise and insert it, Controller Assembly trailing, into the Arbor Housing. Make certain the Bearing Nut Assembly (31) at the front of the motor engages the Arbor Coupling (39).

## MAINTENANCE SECTION

### NOTICE

**The Wheel Guard has left-hand threads.**

- e. While placing the Wheel Guard to the desired position, thread the Guard onto the Arbor Housing and tighten it between 40 and 50 ft-lb (54 and 68 Nm) torque.
- f. Insert the Inner Wheel Flange Key (49) into the slot on the Arbor.
- g. Align the internal slot in the Inner Wheel Flange (48) with the Key and install the Inner Wheel Flange on the Arbor through the Wheel Guard.
- h. Using snap ring pliers, install the Inner Wheel Flange Retainer (50) on the Arbor against the Flange.

### NOTICE

**To seat the Retainer and bias the motor, make a spacer from tubing that will fit over the Arbor and is approximately the size of the Retainer. After sliding the spacer onto the Arbor, thread the Wheel Flange Nut (52) onto the Arbor until the Retainer is snug against the Inner Wheel Flange. Remove the Nut and spacer.**

- i. If the Oil Chamber Plug (3) was removed and the oil drained, fill the oil chamber with Ingersoll-Rand No. 50 Oil and tighten the Plug between 3.5 and 6 ft-lb (5 and 8 Nm) torque.
  - j. Install a grinding wheel, the Outer Wheel Flange (51) and the Wheel Flange Nut (52).
13. **For Models 61H120G4, 61H120L6, 61H150G4 and 61H150L6**, proceed as follows:
- a. If the Dust Washer (45) was removed from the inside of the Wheel End Bearing Cap (46), install a new Washer and impregnate it with Ingersoll-Rand No. 50 Oil.
  - b. Install the Wheel End Bearing (43) on the Arbor and position the Bearing Clamp Washer (44) on the Arbor with the concave end against the Bearing.
  - c. Position the Wheel End Bearing Cap over the Arbor against the Washer.

### NOTICE

**While tightening the Cone Wheel Adapter (53) or Collet Body (54), maintain the alignment of the Bearing, Washer and Cap to facilitate Arbor insertion into the Housing.**

- d. Thread the Cone Wheel Adapter or Collet Body onto the Arbor and tighten it between 14 and 19 ft-lb (19 and 26 Nm) torque.

- e. Apply 1 cc of Ingersoll-Rand No. 68 Grease to the inside surfaces of the Arbor Coupling (39) and install the Coupling on the Bearing Nut at the motor end of the Arbor.
- f. Insert the assembled Arbor, Coupling end first, into the Arbor Housing making certain the Coupling engages the Bearing Nut on the Rotor.

### NOTICE

**The Wheel End Bearing Cap has left-hand threads.**

- g. Thread the Wheel End Bearing Cap into the Arbor Housing and tighten it between 40 and 50 ft-lb (54 and 68 Nm) torque.
- h. If the Oil Chamber Plug (3) was removed and the oil drained, fill the oil chamber with Ingersoll-Rand No. 50 Oil and tighten the Plug between 3.5 and 6 ft-lb (5 and 8 Nm) torque.
- i. **For Models 61H120G4 and 61H150G4**, install the Collet (55), Collet Nut (56) and a burr.
- j. **For Models 61H120L6 and 61H150L6**, install a cone wheel.

## INSPECTING AND RESETTING THE CONTROLLER

Over a period of time, wear on the valve face of the Controller Assembly (17) or on the nozzle face in the Throttle Handle Assembly (1) could cause the Controller to lock the Grinder in an inoperable condition. The cause of the locked condition must be corrected before the Grinder can be operated. To correct the condition, proceed as follows:

1. Using a 5/64" hex wrench, unscrew and remove the two Rear End Plate Retaining Screws (12).
2. Using a wrench on the flats of the Arbor Housing (33) and another on the flats of the Throttle Handle Assembly (1), unscrew and remove the Arbor Housing. Pull the assembled motor out of the Arbor Housing. Remove the two Motor Clamp Washers (30) from the front of the motor or from the inside of the Arbor Housing.
3. Clamp the Bearing Nut Assembly (31) at the front of the motor in a vise with the Controller Assembly upward.
4. Using the Controller Wrench (57) on the flats of the Controller Assembly, unscrew and remove the Controller Assembly.
5. Pull the Rear End Plate Assembly (18) and Rear Rotor Bearing Washer (20) off the Controller.

## MAINTENANCE SECTION

6. The Controller is in the locked position if the lockout gap shown in Dwg. TPD1085 exists and the “A” dimension measures 2.00” (50.8 mm).

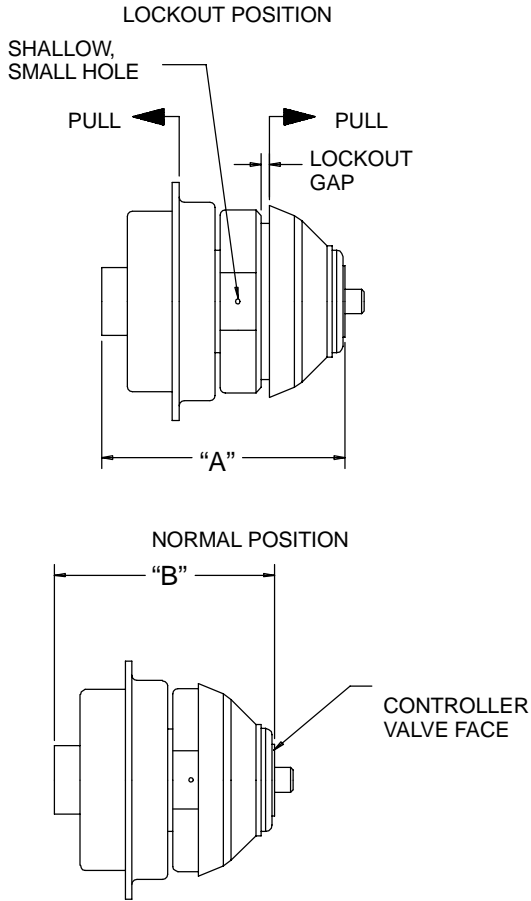

(Dwg. TPD1085)

To reset the Controller, proceed as follows:

- a. One of the flats on the metal ring has a shallow, small hole in the center of the flat. Position that flat upward and grasp the brass wiper plate and the nose cone section of the Controller with your hands.
  - b. While pulling the wiper plate away from the nose cone section, lightly rap the entire Assembly on a workbench surface. Repeat this process until the nose cone section goes flush against the ring when the wiper plate and nose cone are released.
7. After resetting the Controller, and using verniers or a micrometer, measure the length of the Controller from the end of the shaft to the end of the nose cone. If the “B” dimension in Dwg. TPD1085 measures less than 1.896” (48.16 mm), replace the Controller Assembly.

8. To determine if the nozzle face in the Throttle Handle is worn, a measurement must be taken from the nozzle face to the shoulder where the brass wiper plate seats. (Refer to Dwg. TPD1084). If the “C” dimension is greater than 1.365” (34.67 mm), replace the Throttle Handle.

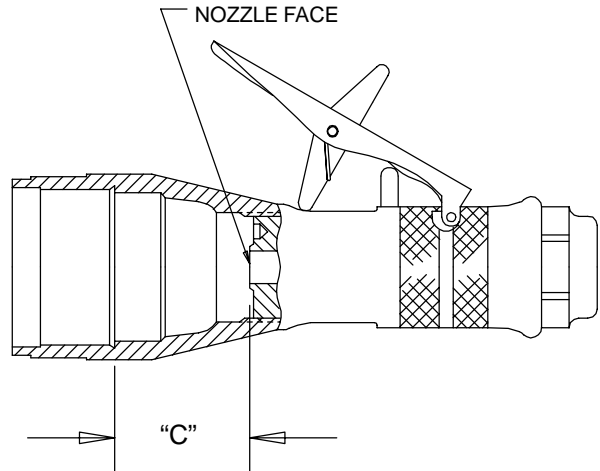

(Dwg. TPD1084)

### NOTICE

**There are a number of ways to obtain the “C” dimension in Dwg. TPD1084. One method is to make a steel plug having a 1.594” (40.5 mm) diameter, a 1/2” (13 mm) hole through the center and both ends surface-ground parallel to a 1.25” (31.75 mm) length. Insert the plug into the Throttle Handle and using a depth micrometer, measure through the plug to the nozzle face. Subtract the length of the plug from the measured length to determine the “C” dimension.**

9. Install the Rear Rotor Bearing Washer into the counterbore of the Rear End Plate Assembly.
10. Insert the Controller Assembly, bearing end leading, into the rear end plate counterbore against the Bearing Washer. Make certain the Wiper Plate Alignment Pin (19) enters the slot in the brass wiper plate of the Controller Assembly.
11. With the Rear End Plate Assembly leading, thread the Controller Assembly onto the shaft of the Rotor (23). Make certain the Cylinder Dowel Pin (22) enters the notch in the End Plate.

## **MAINTENANCE SECTION**

12. Using the Controller Wrench, tighten the Controller Assembly between 8 and 10 ft-lb (10.5 and 13.5 Nm) torque.
13. Drop the two Motor Clamp Washers, concave side trailing, into the large end of the Arbor Housing.
14. Remove the assembled motor from the vise and insert it, Controller Assembly trailing, into the Arbor Housing. Make certain the Bearing Nut Assembly at the front of the motor engages the Arbor Coupling (39).
15. Thread the Throttle Handle Assembly into the assembled Arbor Housing and tighten the joint between 74 and 100 ft-lb (100 and 135 Nm) torque.
16. Install the two Rear End Plate Retaining Screws flush with the handle surface or one thread below flush. If the Screws protrude above the handle surface, the Rear End Plate Assembly is not properly engaged and is out of position.
17. After assembling the tool, test the Grinder. If the Controller length "B" and nozzle face length "C" were within tolerance and the Controller locks the Grinder in an inoperable condition when tested, replace the Controller Assembly.

## MAINTENANCE SECTION

TROUBLESHOOTING		GUIDE
Trouble	Probable Cause	Solution
Low power or low free speed	Insufficient air pressure at the inlet	Check the air pressure at the inlet. It must be 90 psig (6.2 bar/620 kPa).
	Plugged Screen	Clean the Inlet Bushing Screen in a clean, suitable, cleaning solution. If it cannot be cleaned, replace it.  <div style="text-align: center;"><b>⚠ WARNING</b></div> <b>Never operate a Grinder without an Inlet Bushing Screen. Ingestion of dirt into the Grinder can, in some cases, cause an unsafe condition.</b>
	Worn or broken Vanes	Replace a <b>complete</b> set of new Vanes.
	Worn or broken Cylinder	Replace the Cylinder if it appears cracked or if the bore is wavy or scored.
	Improper lubrication or dirt build-up in the motor	Lubricate the Grinder as instructed in <b>LUBRICATION</b> . If lubrication does not result in satisfactory operation, disassemble the motor, clean and inspect all parts.
Rough operation	Worn or broken Rear Rotor Bearing Assembly or Front Rotor Bearing	Examine each bearing. Replace the Rear Rotor Seal Assembly if worn or damaged or replace the Front Rotor Bearing.
	Bent Arbor	Mount the Arbor on centers. Check bearing diameter runout with an indicator. Replace the Arbor if runout exceeds 0.002" (0.051 mm) Total Indicator Reading.
Scoring	Improper assembly	Make certain that <b>all</b> motor parts are properly aligned prior to installing the Handle Assembly into the Arbor Housing.
Air leaks	Worn Valve Seat or Valve Seat Washer	Replace worn parts.
	Worn Throttle Valve Seals	Replace both Seals.
	Oil Chamber Plug worn or not tight	Tighten the Plug. If the problem persists, replace the Plug.
High free speed	Worn Rear End Plate Assembly and/or Controller Seal	Replace the Rear End Plate Assembly if the large inside diameter of the Rear End Plate is worn to 1.156" (38.506 mm) or larger and/or the outside diameter of the Controller Seal is worn to 1.511" (38.379 mm) or smaller.
Grinder will not run	Coupling Nut too tight	Loosen Coupling Nut and retighten to 47.5 to 52.5 ft-lb (64.5 to 71.5 Nm) torque.  <div style="text-align: center;"><b>⚠ WARNING</b></div> <b>Do not exceed 52.5 ft-lb (71.5 Nm) torque.</b>

### NOTICE

**SAVE THESE INSTRUCTIONS. DO NOT DESTROY.**