

2115XP and 2125XP Air Impactool™ Exploded Diagram

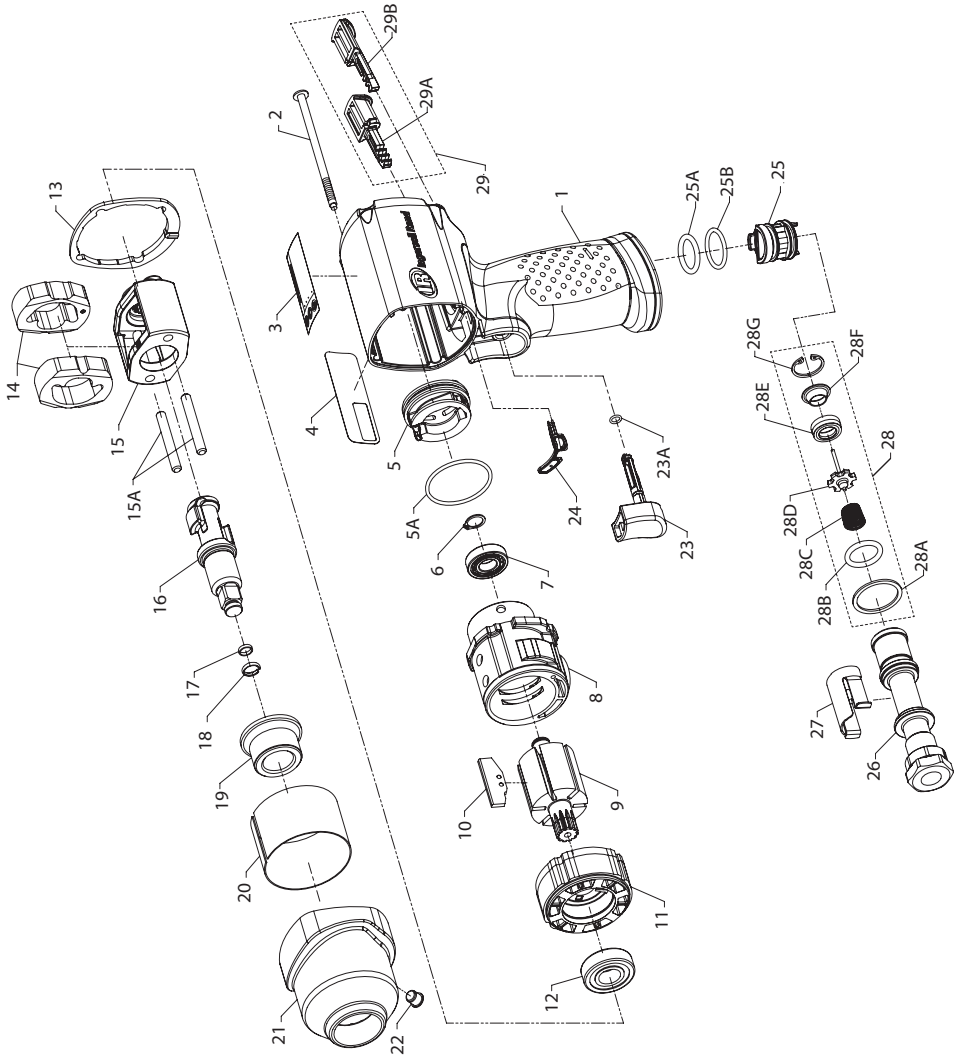

(Dwg. 45633187)

2115XP and 2125XP Air Impactool™ Parts List

Item	Part Description	Part Number	Item	Part Description	Part Number
*	Housing Assembly (2115XP)	2115XP-A40	22	Grease Fitting	1305R-188
*	Housing Assembly (2125XP)	2125XP-A40	† *	Trigger Assembly	2135-D93B
1	Housing	---	23	Trigger	---
3	Warning Label	---	23A	O-Ring, Trigger	---
4	Information Label	---	† 24	Gasket, Motor	2112-283
24	Gasket	---	*	Reverse Valve Assembly	2131-A329
25	Reverse Valve Assembly	---	25	Reverse Valve	---
29	Button Kit	---	25A	O-Ring, Reverse Valve (top)	---
*	Silencers (4)	---	25B	O-Ring, Reverse Valve (bottom)	---
2	Screw, Hammer Case (4 required)	2115-638	26	Inlet Bushing Assembly (includes 27, 28)	2135-D565A
3	Warning Label	WARNING-2-99	27	Inlet Clip	2131-57
4	Information Label (2115XP)	2115XP-300	28	Inlet Parts Kit	2135-K303
4	Information Label (2125XP)	2125XP-300	28A	Washer	---
*	Power Regulator Assembly	2115-D249A	28B	O-Ring, Seal	---
5	Power Regulator	---	28C	Throttle Spring	---
5A	O-Ring, Power Regulator	---	28D	Throttle Valve	---
6	Retaining Ring	4E-6	28E	Valve Seat	---
7	Ball Bearing (Cylinder)	R00H-97	28F	Seat Support	---
8	Cylinder	2112-3	28G	Retainer	---
9	Rotor	2112-53	29	Button Kit	2115-K75RD
† 10	Vane Pack (set of 6)	2112-42-6	29A	Forward Button	---
11	End Plate	2112-11	29B	Reverse Button	---
12	Ball Bearing (End Plate)	2131-97	‡ *	Tune-Up Kit	2115-TK2
† 13	Hammer Case Gasket	2115-36	5A	O-Ring, Power Regulator	---
*	Hammer Mechanism Kit	2115-THK2	6	Retaining Ring	---
15	Hammer Frame	---	7	Ball Bearing (Cylinder)	---
14	Hammer (2)	---	10	Vane Pack (set of 7)	---
15A	Hammer Pin (2)	---	12	Ball Bearing (End Plate)	---
*	Anvil Assembly (2115XP)	2112-A626	13	Hammer Case Gasket	---
*	Anvil Assembly (2125XP)	2112-A726	23A	O-Ring, Trigger	---
16	Anvil	---	24	Gasket, Motor	---
	Socket Retainer Kit	---	25A	O-Ring, Reverse Valve (top)	---
† *	Socket Retainer Kit (3/8" Ring-type) (2115XP)	2115-K425	25B	O-Ring, Reverse Valve (bottom)	---
† *	Socket Retainer Kit (1/2" Ring-type) (2125XP)	2125QTI-K425	28	Inlet Parts Kit	---
17	O-Ring	---	*	Kit, Piped-Away Exhaust	2115-K284
18	Socket Retainer	---	*	Inlet Clip Removal Tool	2131-322
19	Bushing, Hammer Case	2112-641	† *	Air Care Kit (grease gun, grease, oil)	115-LBK1
*	Hammer Case Assembly	2115AL-D727A	*	Grease (replacement tube for -LBK1)	115-4T
19	Bushing, Hammer Case	---	*	Air Tool Oil (4 oz. Bottle)	1024
20	Sleeve, Hammer Case	---	*	Grease (1 lb can)	105-1LB
21	Hammer Case	---	*	Grease (8 lb can)	105-8LB
22	Grease Fitting	---	*	Grease Gun	R000A2-228

* Not illustrated.

† To keep downtime to a minimum, it is desirable to have certain repair parts on hand. We recommend that you stock one (pair or set) of each part indicated by a (†) for every four tools in service.

‡ Please note that the standard Tune-Up kit 2115-TK2 includes 7 replacement vanes. The 2115XP and 2125XP requires only 6 vanes.

Parts and Maintenance

When the life of the tool has expired, it is recommended that the tool be disassembled, degreased and parts be separated by material so that they can be recycled.

Tool repair and maintenance should only be carried out by an authorized Service Center.

Refer all communications to the nearest **Ingersoll Rand** Office or Distributor.

Related Documentation

For additional information refer to:

Air Impact Wrench Product Safety Information Manual 04580916.

Air Impact Wrench Product Information Manual 45604196.

Manuals can be downloaded from www.irtools.com.



www.irtools.com

© 2008 **Ingersoll Rand** Company

45634375

Edition 1

December 2008