

# 2115Qi and 2125Qi Air Impactool™ - Exploded View

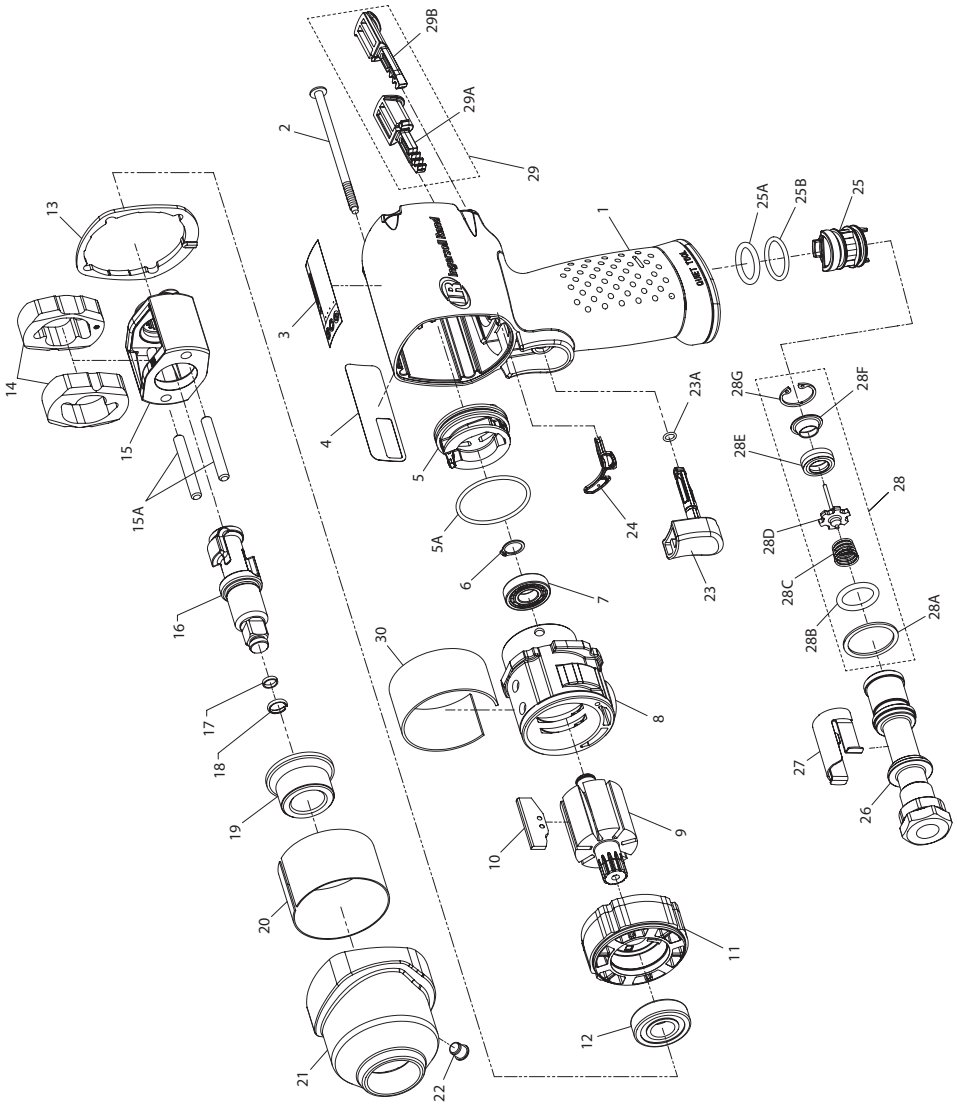

(Dwg. 45609054)

## 2115Qi and 2125Qi Air Impactool™ - Parts List

Item	Part Description	Part Number	Item	Part Description	Part Number
*	Housing Assembly		22	Grease Fitting	130SR-188
	for model 2115Qi	2115Qi-A40	†*	Trigger Assembly	2135-D93B
	for model 2125Qi	2125Qi-A40	23	Trigger	---
1	Housing	---	23A	O-Ring, Trigger	---
3	Warning Label	---	† 24	Gasket, Motor	2112-283
4	Information Label	---	*	Reverse Valve Assembly	2131-A329
24	Gasket, Motor	---	25	Reverse Valve	---
*	Reverse Valve Assembly	---	25A	O-Ring, Reverse Valve (Top-Black)	---
29	Button Kit	---	25B	O-Ring, Reverse Valve (Bottom-Blue)	---
2	Screw, Hammer Case (4 required)	2115-638	*	Inlet Bushing Assembly	2135-D565A
3	Warning Label	WARNING-2-99	26	Inlet Bushing	---
4	Information Label		27	Inlet Clip	2131-57
	for model 2115Qi	2115Qi-300	28	Inlet Parts Kit	2135-K303
	for model 2125Qi	2125Qi-300	28A	Washer	---
*	Power Regulator Assembly	2115-D249A	28B	O-Ring, Seal	---
5	Power Regulator	---	28C	Throttle Spring	---
5A	O-Ring, Power Regulator	---	28D	Throttle Valve	---
6	Retaining Ring	4E-6	28E	Valve Seat	---
7	Ball Bearing (Cylinder)	R00H-97	28F	Seat Support	---
8	Cylinder	2112-3	28G	Retainer	---
9	Rotor	2115-53	29	Button Kit	2115-K75RD
† 10	Vane Pack (set of 7)	2115-42A-7	29A	Forward Button	---
11	End Plate	2112-11	29B	Reverse Button	---
12	Ball Bearing (End Plate)	2131-97	30	Silencer	2115Q-311
† 13	Hammer Case Gasket	2115-36	*	Tune-Up Kit	2115-TK2
*	Hammer Mechanism Kit	2115-THK2	5A	O-Ring, Power Regulator	---
14	Hammer (2)	---	6	Retaining Ring	---
15	Hammer Frame	---	7	Ball Bearing (Cylinder)	---
15A	Hammer Pin (2)	---	10	Vane Pack (set of 7)	---
*	Anvil Assembly		12	Ball Bearing (End Plate)	---
	for model 2115Qi	2112-A626	13	Hammer Case Gasket	---
	for model 2125Qi	2112-A726	23A	O-Ring, Trigger	---
16	Anvil	---	24	Gasket, Motor	---
*	Socket Retainer Kit	---	25A	O-Ring, Reverse Valve (Top-Black)	---
†*	Socket Retainer Kit		25B	O-Ring, Reverse Valve (Bottom-Blue)	---
	for model 2115Qi (3/8" Ring-type)	2115-K425	28	Inlet Parts Kit	---
	for model 2125Qi (1/2" Ring-type)	2125QTi-K425	*	Kit, Piped-Away Exhaust	2115-K284
17	O-Ring	---	*	Inlet Clip Removal Tool	2131-322
18	Socket Retainer	---	†*	Air Care Kit (grease gun, grease, oil)	115-LBK1
19	Bushing, Hammer Case	2112-641	*	Grease (replacement tube for -LBK1)	115-4T
*	Hammer Case Assembly	2115AL-D727A	*	Air Tool Oil (4 oz. bottle)	1024
19	Bushing, Hammer Case	---	*	Grease (1 lb can)	105-1LB
20	Sleeve, Hammer Case	---	*	Grease (8 lb can)	105-8LB
21	Hammer Case	---	*	Grease Gun	R000A2-228
22	Grease Fitting	---			

\* Not illustrated.

† To keep downtime to a minimum, it is desirable to have certain repair parts on hand. We recommend that you stock one (pair or set) of each part indicated by a (†) for every four tools in service.

## Parts and Maintenance

When the life of the tool has expired, it is recommended that the tool be disassembled, degreased and parts be separated by material so that they can be recycled.

Tool repair and maintenance should only be carried out by an authorized Service Center.

Refer all communications to the nearest **Ingersoll Rand** Office or Distributor.

## Related Documentation

For additional information refer to:

Air Impact Wrench Product Safety Information Manual 04580916.

Air Impact Wrench Product Information Manual 45553518.

Manuals can be downloaded from [www.ingersollrandproducts.com](http://www.ingersollrandproducts.com).



[www.ingersollrandproducts.com](http://www.ingersollrandproducts.com)  
© 2011 **Ingersoll-Rand** Company

45603537  
Edition 2  
August 2011