

2150 and 2151S Air Impact Wrench Exploded Diagram

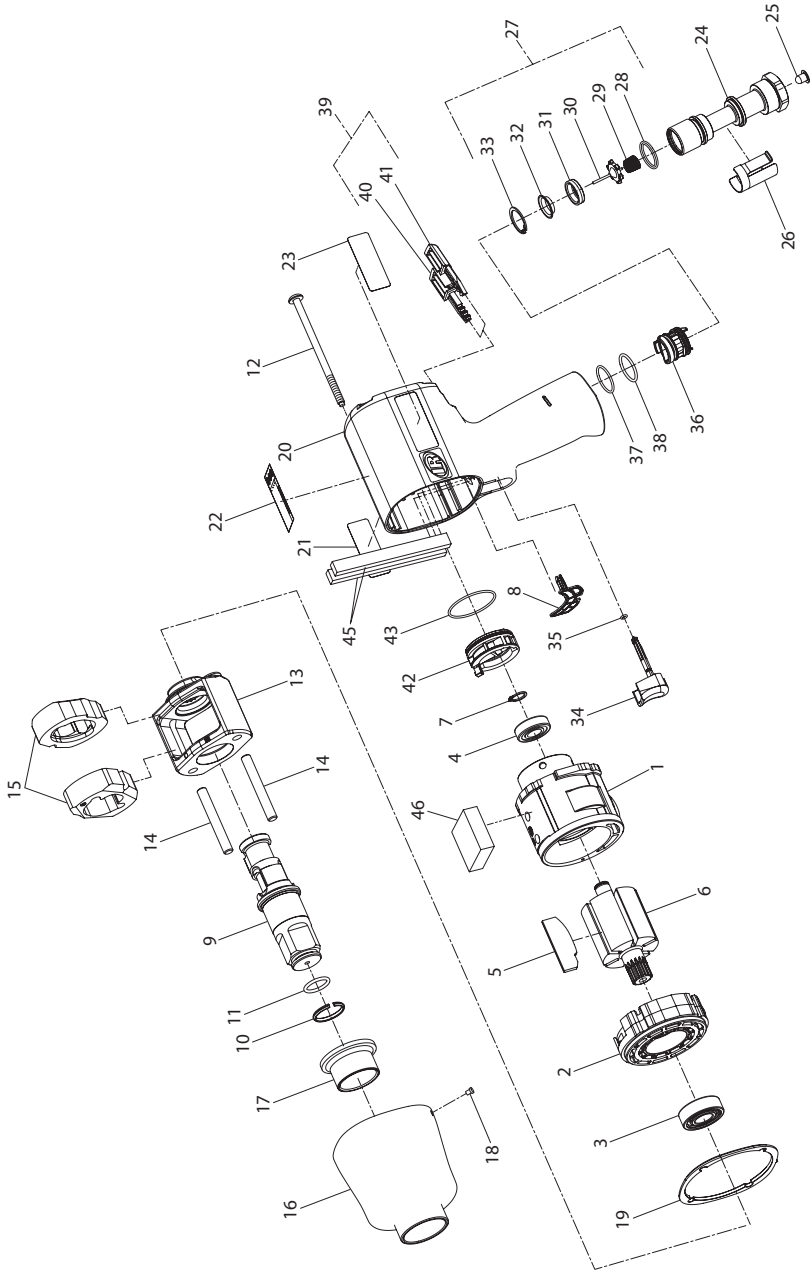

(Dwg. TP1989)

2150 and 2151S Air Impact Wrench Parts List

Item	Part Description	Part Number	Item	Part Description	Part Number
1	Cylinder	2141-3	25	Inlet Bushing Screen	5RA-61
2	Front End Plate	2141-11	26	Inlet Retainer Clip	2141-57
3	Front Rotor Bearing	R38P-606	27	Inlet Parts Kit	2141-K303
4	Rear Rotor Bearing	2131-97	28	Inlet Bushing Seal	R4-210
• 5	Vane Packet (set of 6 Vanes)	2141-42-6	29	Tilt Valve Spring	2131-51
6	Rotor	2141-53	30	Tilt Valve	2141-302
7	Rear Rotor Bearing Retainer	2131-6	31	Tilt Valve Seat	2141-303
• 8	Motor Gasket	2141-283	32	Tilt Valve Seat Support	2141-306
9	Anvil Assembly	2150-A726	33	Tilt Valve Seat Retainer	SML8-24
• 10	Socket Retainer	910E5-918	• 34	Trigger Assembly	2141-A93
• 11	Socket Retainer O-ring	BBFM-557	35	Trigger O-ring	---
12	Hammer Case Screw (4)	2141-638	36	Reverse Valve Assembly	2141-A329
	Hammer Frame Assembly	2141-A703	37	Reverse Valve O-ring (top)	---
13	Hammer Frame	2141-703	38	Reverse Valve O-ring (bottom) (blue)	---
14	Hammer Pin (2)	2141-704	39	Button Kit	2141-K75
15	Hammer (2)	2141-724	40	Forward Button	---
16	Hammer Case Assembly (2150)	2141P3-A727	41	Reverse Button	---
	Hammer Case Assembly (2151S)	2151-A727	42	Power Management Dial	2131-A249
17	Hammer Case Bushing (2150)	VW-1136	43	Power Management Dial Seal	---
	Hammer Case Bushing (2151S)	2151-641	44	Silencer (2) (2151S only)	2131S-310
18	Grease Fitting	D0F9-879	45	Exhaust Silencer (2151S only)	2131S-311
• 19	Hammer Case Gasket	2141-36	*	Inlet Clip Removal Tool	2131-322
20	Housing Assembly (2150)	2141-A40	*	Grease (1 lb) (for external lubrication of the impact mechanism)	115-1LB
	Housing Assembly (2151S)	2151S-A40			
21	Housing Label (2150)	2141-99	*	Grease (for lubrication when disassembling and assembling the impact mechanism)	
	Housing Label (2151S)	2151S-300			
22	Warning Label	WARNING-2-99		1 lb	105-1LB
23	Nameplate (2151S)	2151S-301		8 lb	105-8LB
23	Nameplate (2150)	2150-301	*	Protective Cover	2141-P32
	Inlet Bushing Assembly	2141-D565	*	Grease Gun	R000A2-228
24	Inlet Bushing	2141-565			

* Not illustrated.

- To keep downtime to a minimum, it is desirable to have on hand certain repair parts. We recommend that you stock one (pair or set) of each part indicated by a Bullet (-) for every four tools in service.

Parts and Maintenance

When the life of the tool has expired, it is recommended that the tool be disassembled, degreased and parts be separated by material so that they can be recycled.

Tool repair and maintenance should only be carried out by an authorized Service Center.

Refer all communications to the nearest **Ingersoll Rand** Office or Distributor.

Related Documentation

For additional information refer to:

Air Impact Wrench Product Safety Information Manual 04580916.

Air Impact Wrench Product Information Manual 04584710.

Air Impact Wrench Maintenance Information Manual Form 04584074.

Manuals can be downloaded from www.irtools.com.