



**Industrial** Tools



# ERGONOMICS

For optimized  
workstation

More Than Productivity



# Optimized workstations

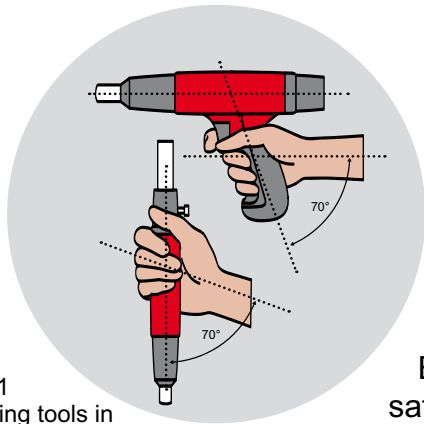

Fig. 1  
Holding tools in  
an ergonomically  
neutral position

Ergonomics deals with the interactions between operators and their work equipment, work environment and work process

Ergonomically designed work systems enhance safety, effectiveness and efficiency, improve human working and living conditions, and counteract adverse effects on human health and performance

Desoutter has been developing products to improve the comfort of use and counter balance some of the below situations:

1. Hand position on the tool: based on application a straight or pistol grip tool is suggested (Fig. 1)
2. Tool position in the workspace: easy to reach and at the right height to minimize the unnecessary movement of the operator (Fig. 2 and 3)
3. Forces exerted: pulling force, torque reaction and the repetitiveness of these forces (Fig. 2 and 3)

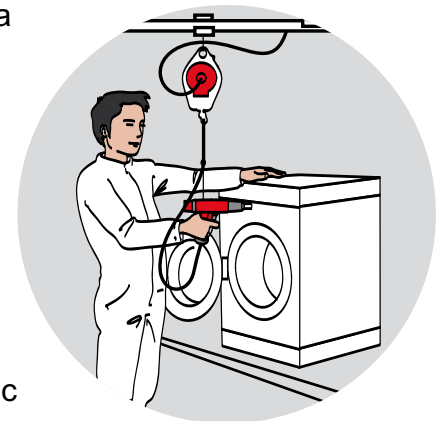

Fig. 2  
Desoutter balancer

The potential benefits of using Desoutter ergonomic accessories together with tools as described in this brochure are:

- Reduce repetitive stress injuries (RSI)
- Reduced operator fatigue
- Greater productivity
- Improved quality
- Reduced handling time
- Greater operator satisfaction
- Lower recruitment costs

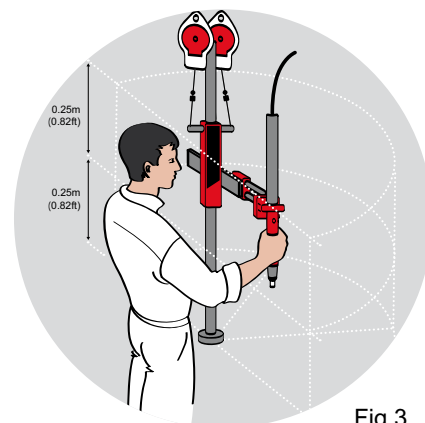

Fig.3  
Desoutter torque  
reaction arm

# Contents

---

Why do you need a torque arm?	Page 4
D53 linear and folded torque reaction arms	Pages 5 to 7
TRA telescopic reaction arms	Page 8
Tool clamp and options	Page 9
Tool position with torque reaction arms	Page 10
Bench kit and swinging arm	Page 11
Balancers	Pages 12-13
Tool holster - Air-Flex	Page 14
Automatic Screw Dispenser	Page 15

---

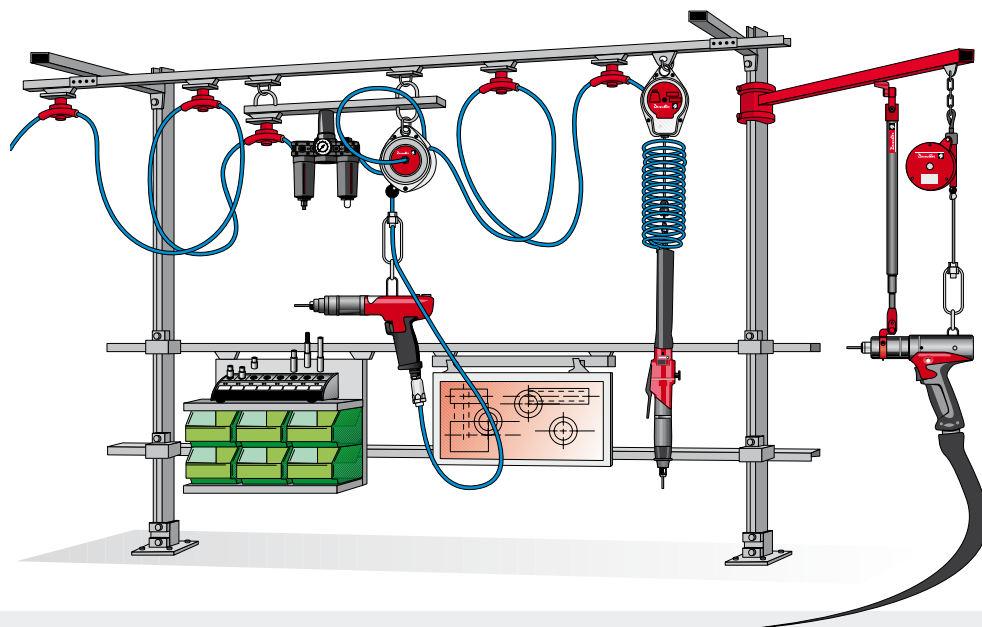

## Why do you need a torque arm?

### Takes away the tool torque & weight from the operator wrist

- Improves work condition
- Criteria? Torque & repetitiveness
  - Straight tool if higher torque than 3Nm
  - Pistol grip if higher torque than 6Nm
  - Angle nut runner if higher torque than 30Nm
- Reduces repetitive stress injuries (RSI) cost

### Tool holder at the workstation

- Optimizes workstation with tool at reach
- Keeps the tool at the ideal height

### Improves quality of work and torque accuracy

- Avoids tool twisting in the hand
- Keeps the tool perfectly straight for tightening

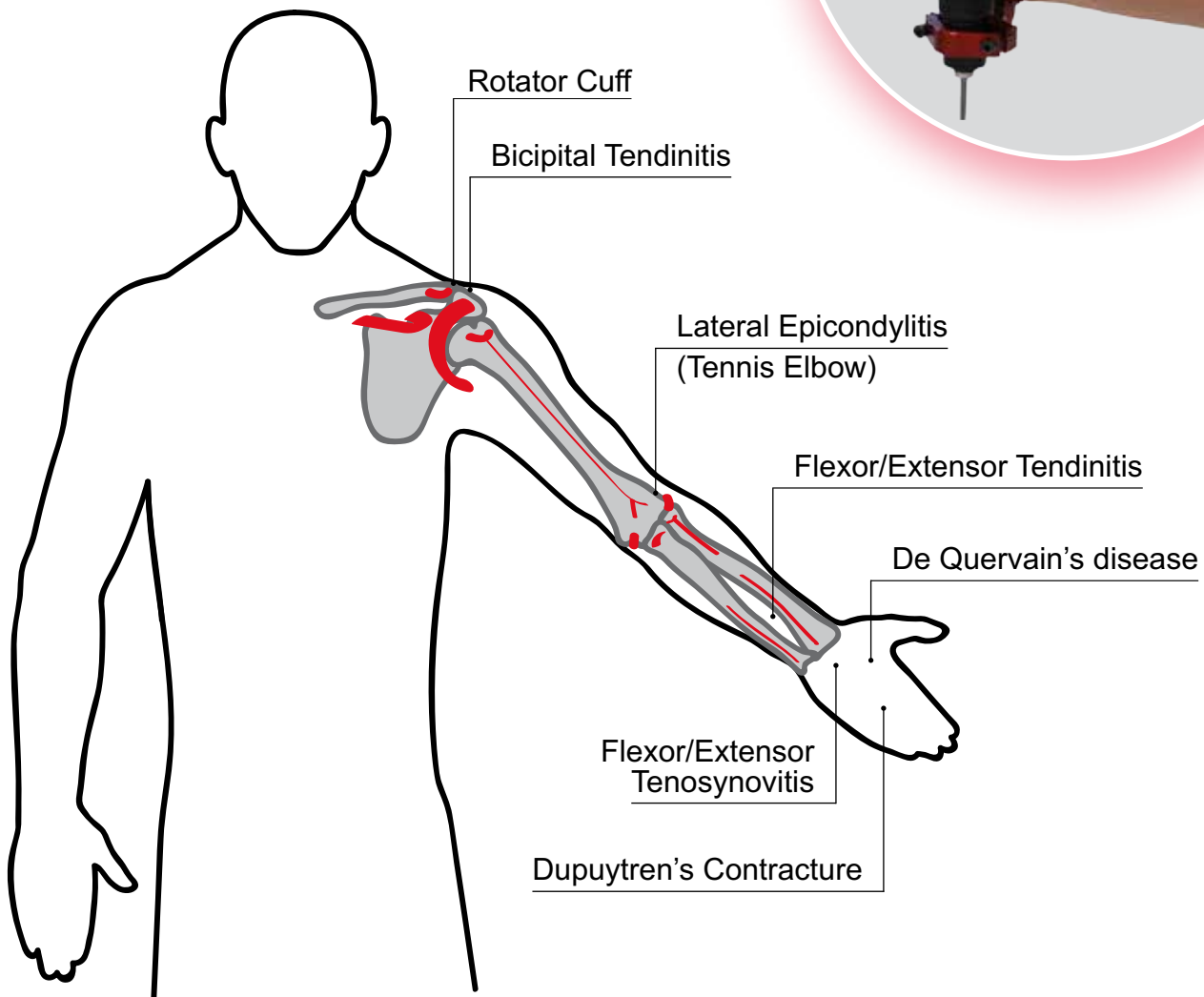

# D53 linear torque reaction arm

The revival of the all time classic linear design!

- From 5 up to 100 Nm (3.7 up to 73.7 ft.lb)
- 90 degrees tool clamp interface for straight or pistol grip tools

**Benefits:**

- Takes away the tool torque & weight from the operator wrist
- Improves quality of work and torque accuracy

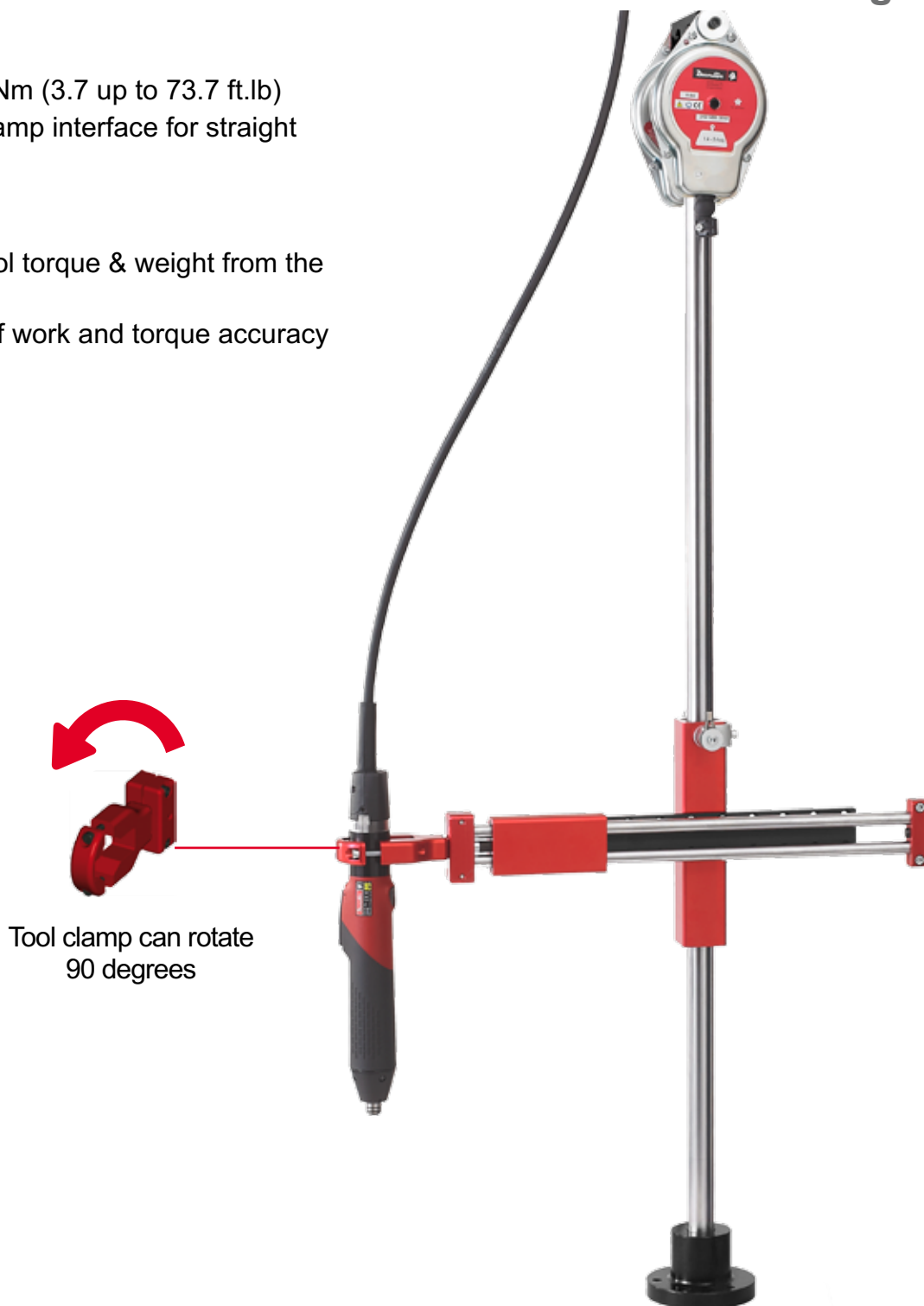

Tool clamp can rotate 90 degrees

For full tool clamp program, please see details on page 9

MODEL	PART NUMBER D53 LINEAR ARM	MAXIMUM TORQUE		MAXIMUM TOOL WEIGHT		BALANCER EQUIPPED WITH	TOOL CLAMP DIAMETER (INCLUDED WITH THE ARM)	
		Nm	ft. lb	kg	lb.		mm	in.
D53-5*	615 810 700 0	5	3.7	0.8	1.8	1x5DU	28.5-41	1.12-1.62
D53-12*	615 810 701 0	12	8.8	1.5	3.3	2x5DU	28.5-41	1.12-1.62
D53-25*	615 810 702 0	25	18.4	2.5	5.5	2x5DU	28.5-41	1.12-1.62
D53-25X Extended reach*	615 810 703 0	25	18.4	2.2	4.8	2x5DU	28.5-41	1.12-1.62
D53-50	615 810 704 0	50	36.8	5.0	11.0	2x15D	To order separately	
D53-100	615 810 705 0	100	73.7	6.0	13.2	2x22D		

(\* ) Universal D53 tool clamp included

# D53 folded torque reaction arm

For more flexibility and greater area of reach!

- From 5 up to 100 Nm (3.7 up to 73.7 ft.lb)
- 90 degrees tool clamp interface for straight or pistol grip tools

**Benefits:**

- Greater working area covered
- Takes away the tool torque & weight from the operator wrist
- Improves quality of work and torque accuracy



Tool clamp can rotate 90 degrees

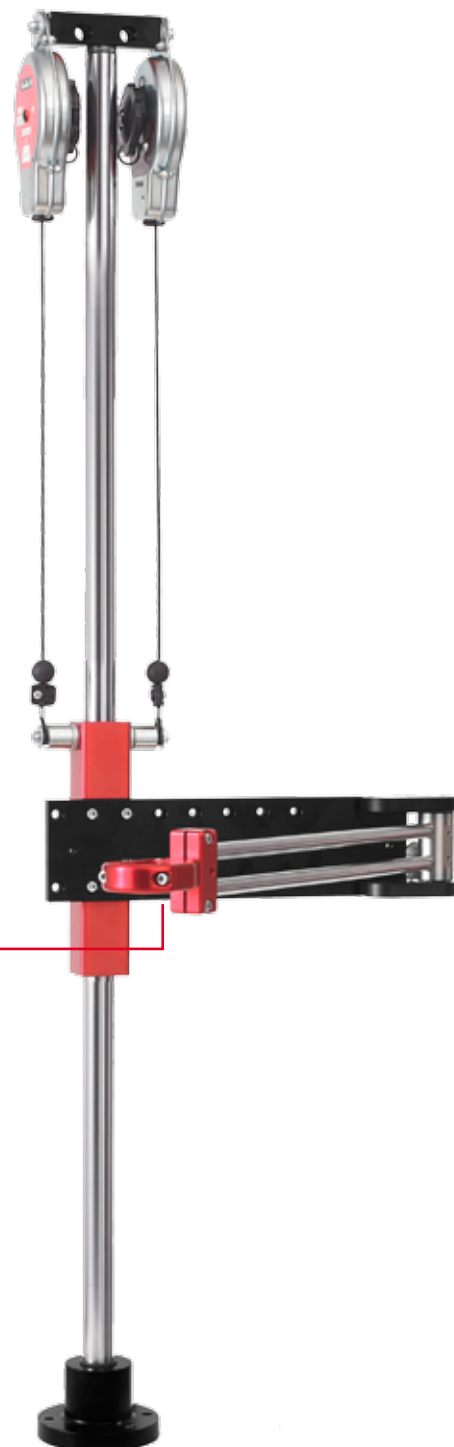

For full tool clamp program, please see details on page 9

MODEL	PART NUMBER D53 FOLDED ARM	MAXIMUM TORQUE		MAXIMUM TOOL WEIGHT		BALANCER EQUIPPED WITH	TOOL CLAMP DIAMETER (INCLUDED WITH THE ARM)	
		Nm	ft. lb	kg	lb.		mm	in.
D53-5S*	615 810 706 0	5	3.7	0,8	1,8	1x5DU	28.5-41	1.12-1.62
D53-12S*	615 810 707 0	12	8.8	1,5	3,3	2x5DU	28.5-41	1.12-1.62
D53-25S*	615 810 708 0	25	18.4	2,5	5,5	2x5DU	28.5-41	1.12-1.62
D53-50S	615 810 709 0	50	36.8	5,0	11,0	2x15D		
D53-100S	615 810 710 0	100	73.7	6,0	13,2	2x22D		

(\*) Universal D53 tool clamp included

# D53 arm dimensions

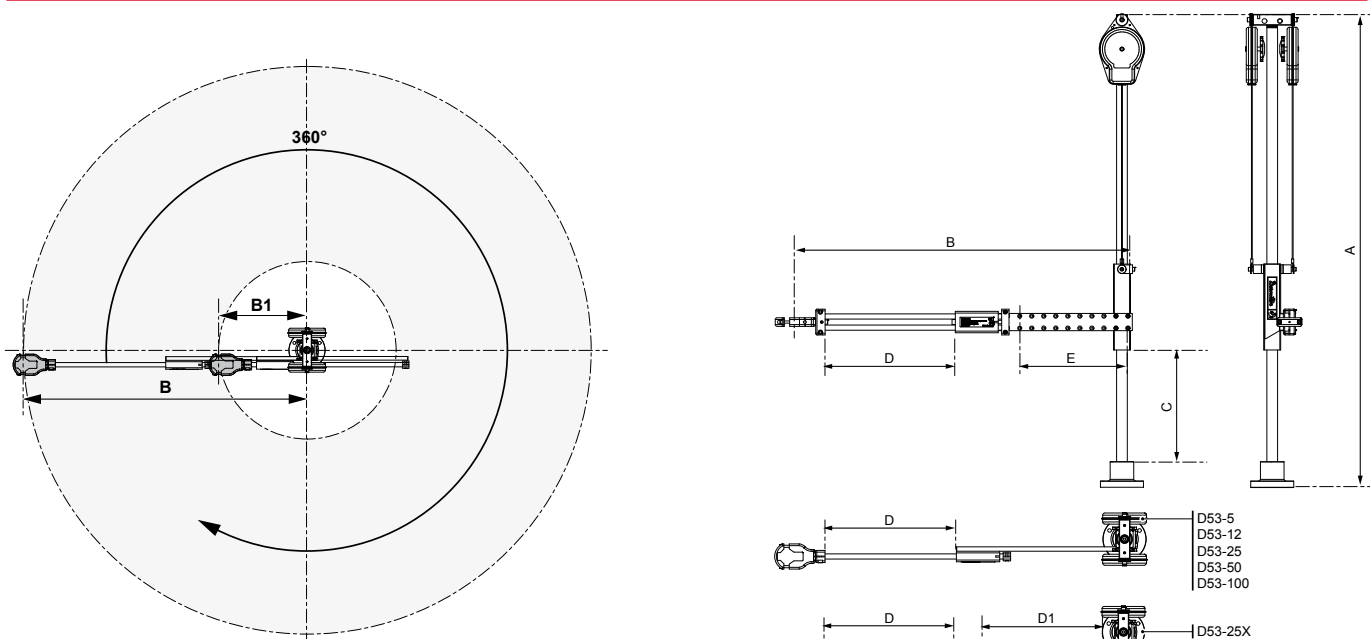

## D53 linear working area product specification

MODEL	PART NUMBER	MAXIMUM TORQUE		HEIGHT A		WIDTH			VERTICAL STROKE C		HORIZONTAL STROKE			FIXED STROKE E		TOOL WEIGHT MAX		
		Nm	ft. lb	mm	in	MAXI-B	MINI-B	mm	in	mm	in	mm	in	mm	in	kg	lb	
D53-5	615 810 700 0	5	3.7	732	28.8	592*	23.3*	220*	8.7*	310	12.2	205	8.1	-	168	6.6	0.8	1.76
D53-12	615 810 701 0	12	8.9	888	35.0	710*	28*	260*	10.2*	465	18.3	255	10.0	-	196	7.7	1.5	3.3
D53-25	615 810 702 0	25	18.4	1100	43.3	777*	30.6*	237*	9.3*	615	24.2	290	11.4	-	252	9.9	2.5	5.5
D53-25X	615 810 703 0	25	18.4	1100	43.3	794*	31.2*	230*	9.0*	615	24.2	290	11.4	283	11.1	-	2.2	4.85
D53-50	615 810 704 0	50	36.9	1116	43.9	887**	34.9**	267**	10.5**	515	20.3	355	14.0	-	266	10.5	5.0	11.0
D53-100	615 810 705 0	100	73.8	1116	43.9	914**	36**	255**	10.0**	515	20.3	395	15.6	-	266	10.5	6.0	13.2

(\*) With clamp - (\*\*) Without clamp

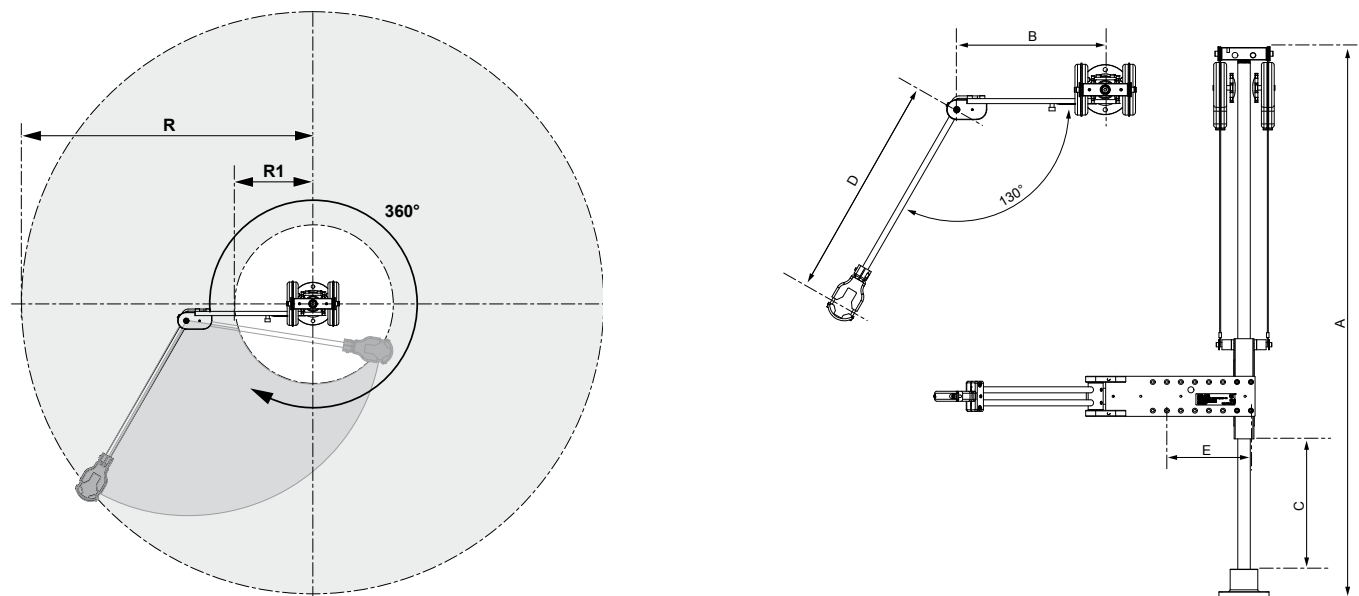

## D53 folded working area product specification

MODEL	PART NUMBER	MAXIMUM TORQUE		HEIGHT A		WIDTH B		VERTICAL STROKE C		RADIUS D		FIXED STROKE E		RADIUS R		RADIUS R1		TOOL WEIGHT MAX	
		Nm	ft. lb	mm	in	mm	in	mm	in	mm	in	mm	in	mm	in	mm	in	kg	lb
D53-5 S	6158107060	5	3.7	732	28.8	248	9.76	270	10.6	370*	14.6*	168	6.6	546	21.5	140	5.5	0.8	1.76
D53-12 S	6158107070	12	8.9	888	35.0	298	11.73	425	16.7	420*	16.5*	168	6.6	639	25.2	146	5.8	1.5	3.3
D53-25 S	6158107080	25	18.4	1100	43.3	296	11.65	580	22.8	470*	18.5*	168	6.6	685	27	183	7.2	2.5	5.5
D53-50 S	6158107090	50	36.9	1116	43.9	336	1.1	520	20.5	440**	17.3**	228	9.0	698	27.5	154	6.1	5.0	11.0
D53-100 S	6158107100	100	73.8	1116	43.9	391	15.4	500	19.7	490**	19.3**	228	9.0	788	31	158	6.2	6.0	13.2

(\*) With clamp - (\*\*) Without clamp

# TRA telescopic reaction arms

## Telescopic carbon arm: Ideal for busy workspace!

- From 12 up to 200 Nm (8.9 up to 148 ft.lb) torque capacity
- Several lengths available
- 90 degrees tool clamp interface for straight or pistol grip tools
- Limited tool clamp angle rotation to avoid side forces in the operator arm ( $\omega$ ) (Fig 1)

### Benefits:

- Extremely lightweight carbon made torque arm for improved comfort of use
- Flexible solution

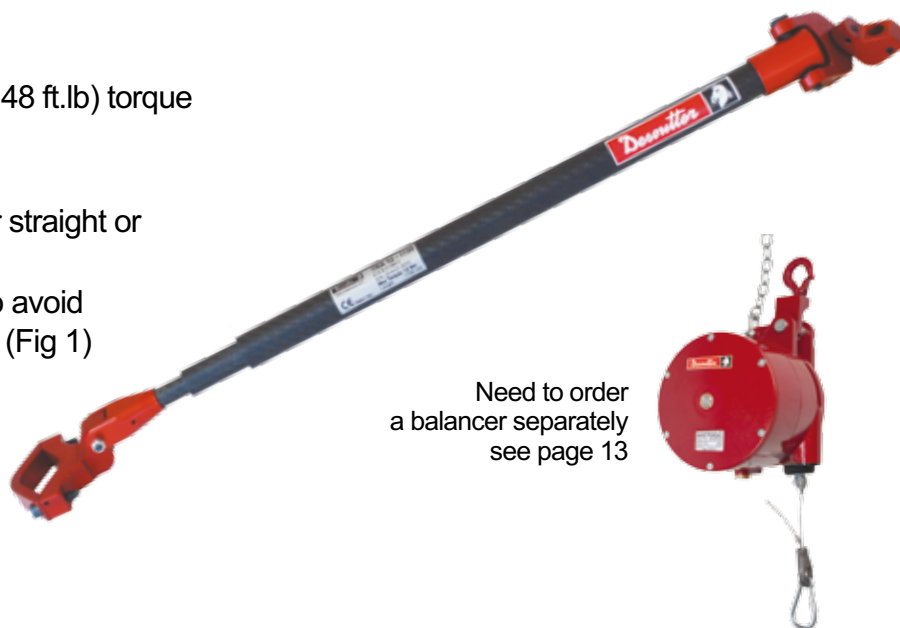

Need to order a balancer separately see page 13



\*\*Universal balancer adapter

MODEL	PART NUMBER	MAXIMUM TORQUE		MAX. MIN LENGTH		$\omega$ (deg)	TOOL CLAMP DIAMETER (INCLUDED WITH THE ARM)	
		Nm	ft. lb	mm	in.		mm	in.
TRA12 1150*	615 810 089 0	12	8.9	516-1128	20.3-44.4	60	28-49	1.10-1.92
TRA12 1600*	615 810 090 0	12	8.9	666-1578	26.2-62.1	60	28-49	1.10-1.92
TRA12 2100*	615 810 091 0	12	8.9	835-2083	32.9-82	60	28-49	1.10-1.92
TRA25 1150*	615 810 092 0	25	18.4	524-1124	20.6-44.3	50	28-49	1.10-1.92
TRA25 1600*	615 810 093 0	25	18.4	674-1574	26.5-62	50	28-49	1.10-1.92
TRA25 2100*	615 810 094 0	25	18.4	841-2075	33.1-81.7	50	28-49	1.10-1.92
TRA25 2600*	615 810 095 0	25	18.4	1007-2573	39.6-101.3	50	28-49	1.10-1.92
TRA50 1600*	615 810 096 0	50	36.9	712-1624	28-63.9	40	28-50	1.10-1.97
TRA50 2100*	615 810 097 0	50	36.9	878-2125	34.6-83.7	40	28-50	1.10-1.97
TRA50 2600*	615 810 098 0	50	36.9	1045-2626	41.1-103.4	40	28-50	1.10-1.97
TRA100 1600	615 810 099 0	100	73.8	722-1628	28.4-64.1	30	To order separately see page 9	
TRA100 2100	615 810 100 0	100	73.8	889-2129	35-83.8	30		
TRA100 2600	615 810 101 0	100	73.8	1056-2630	41.6-103.5	30		
TRA200 1600	615 810 102 0	200	148	726-1628	28.6-64.1	20		
TRA200 2100	615 810 103 0	200	148	893-2129	35.2-83.8	20		
TRA200 2600	615 810 104 0	200	148	1060-2630	41.7-103.5	20		

(\*) Universal TRA tool clamp included (\*\*) Universal balancer adapters: 1 kit = 7 parts for all Desoutter balancer types: Part No. 615 397 922 5



# Tool clamp program for D53 and TRA torque reaction arms



PART NUMBER	DESCRIPTION	TOOL DIAMETER		FOR ARMS		PIC REF
		mm	in	D53	TRA	
<b>UNIVERSAL CLAMP</b>						
615 810 835 0	D53 Universal clamp	28.5-41	1.12-1.62	D53-5/12/25	TRA-12/25	<b>A</b>
615 810 838 0	D53 Universal clamp	40-50	1.57-1.97	D53-5/12/25	TRA-12/25	
615 810 899 0	D53 Universal clamp	26-55	1.02-2.16	D53-50/100	TRA-50/100	
615 810 118 0	TRA Universal clamp	28-49	1.10-1.92	D53-5/12/25	TRA-12/25	<b>B</b>
615 810 137 0	TRA Universal clamp	28-50	1.10-1.97	D53-50/100	TRA-50/100	
<b>SPECIFIC DIAMETER CLAMP</b>						
615 810 125 0	Tool clamp 34	34.0	1.33	D53-5/12/25	TRA-12/25	<b>C</b>
615 810 127 0	Tool clamp 36.5	36.5	1.43	D53-5/12/25	TRA-12/25	
615 810 129 0	Tool clamp 38	38.0	1.49	D53-5/12/25	TRA-12/25	
615 810 131 0	Tool clamp 44	44.0	1.73	D53-5/12/25	TRA-12/25	
<b>SPLINE CLAMP</b>						
615 810 203 0	Clamp for 50-100 ERDL4 - ECD50-70	Spline G1-40.5	1.59	D53-50/100	TRA-50/100	<b>D</b>
615 810 205 0	Clamp for 50-100 ERDL6	Spline G1-50	1.97	D53-50/100	TRA-50/100	
<b>WELDED CLAMP (to be welded with the spline ring supplied with the tool)</b>						
615 810 628 0	Clamp to weld for 50-100 Nm (36.9-73.7 ft.lb)			D53-50 / 100	TRA-50/100	<b>E</b>
615 810 631 0	Clamp to weld up to 200 Nm ( 147.5 ft.lb)				TRA-200	

**Universal clamp  
D53 style**

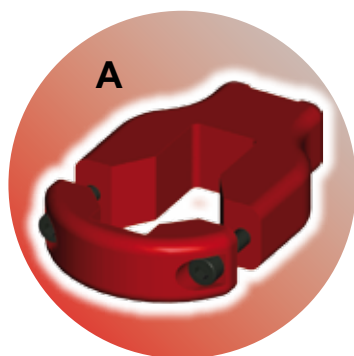

**Universal clamp  
TRA style**

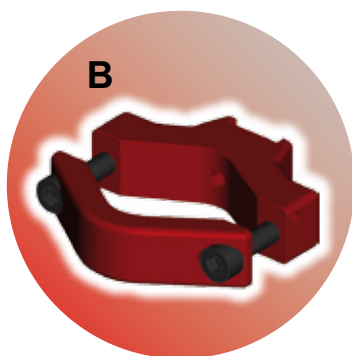

**Universal clamp  
Rotation capability**

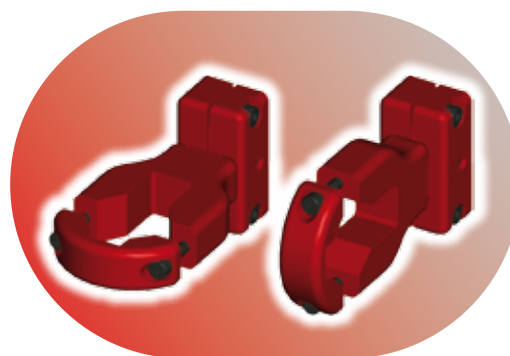

**Specific diameter  
clamp**

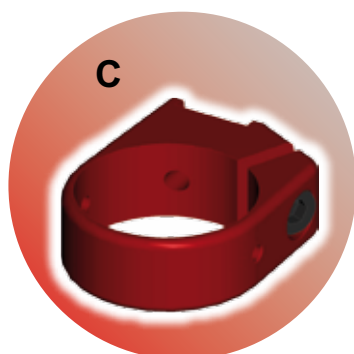

**Spline clamp**

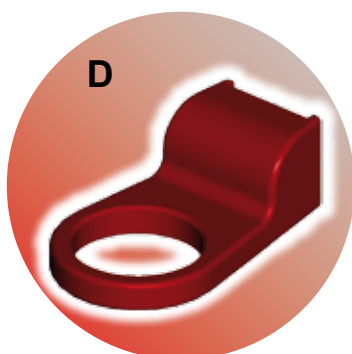

**Clamp to weld (50 to 200 Nm)  
Rotation capability**

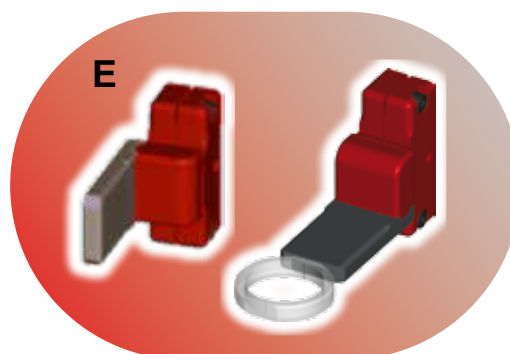

# Tool position with torque reaction arms

## D53 tool position

Straight tool

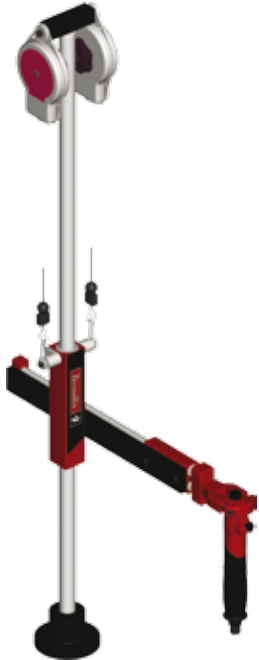

Pistol grip tool



Angle nutrunner



## TRA tool position

Straight tool



Angle nutrunner

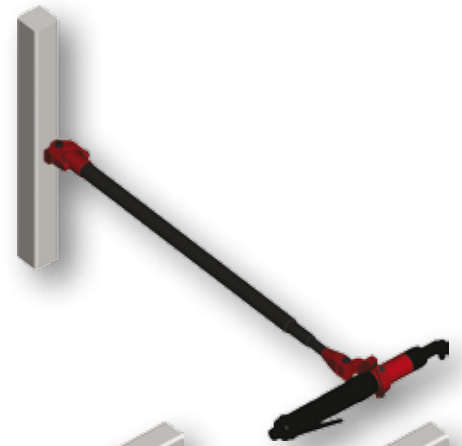
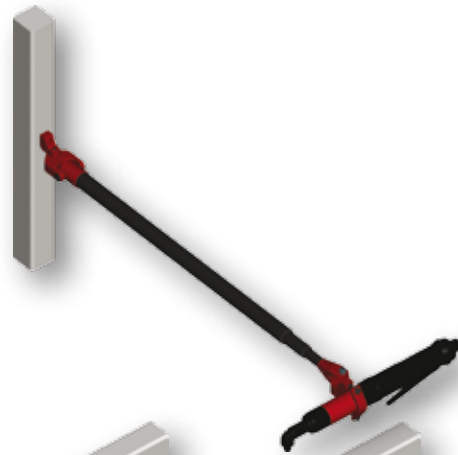

Pistol grip tool

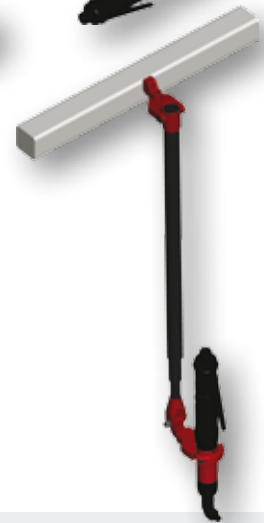

# Bench kit & swinging arm

- Three complete bench kits to suit: 1.5 m (4.92ft), 2 m (6.56ft), 2.5 m (8.2ft) bench widths with flexibility of mounting in height and spacing of upright supports
- Everything included to set up a simple system within minutes. It can be enhanced with the accessories shown in the Desoutter general catalogue dedicated page 120, adding to the versatility
- Supplied in 2 packs, needing only 10/13/17mm A/F wrenches and standard screwdrivers to assemble



## COMPLETE BENCH KIT READY TO ASSEMBLE

Each kit consist of:

- Tool Suspension Track of specified length
- Hose trolley
- Horizontal outrigger arms
- Hose clamp
- Vertical C-rail uprights with base for benchtop mounting (2 uprights with 1.5 m (4.92ft) and 2 m (6.56ft) kits, 3 with 2.5 m (8.2ft) kits)
- All necessary brackets, fittings and end stops/clamps
- Simple, step by step assembly instructions
- Tool Suspension trolley with 3 suspension rings and hoseclamp

## EXAMPLE OF INSTALLATION

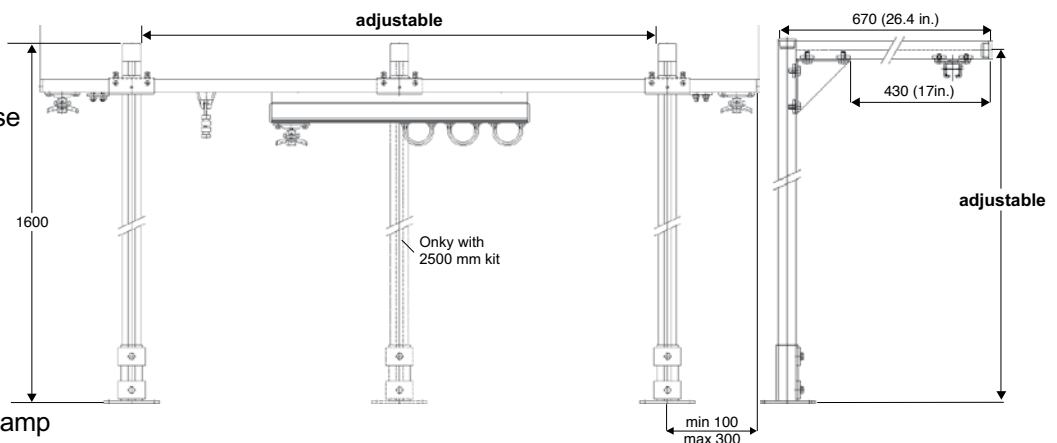

PIC REF	PART NUMBER	LENGTH OF SUSPENSION TRACK		HEIGHT		HORIZONTAL STROKE		WEIGHT LOAD	
		Nm	ft. lb	mm	in.	mm	in.	kg	lb.
<b>BENCH TIDY</b>									
A	111672	1500	59.0	1600	63			22	48.5
A	111682	2000	78.7	1600	63			24	53.0
A	111692	2500	98.4	1600	63			26	57.0
<b>BENCH MOUNTED SWINGING ARM</b>									
B	66542			1600	63	630	24.8	10	22.0

For bench kit accessories, please refer to the dedicated page in the Desoutter general catalogue

# Balancers - D, HU & R Series



- Steel housing
- Nylon (pic A)  
Steel (pic B) cable
- Additional support chain included
- 10S / 15S / 22S with drum lock feature: operates only on spring failure

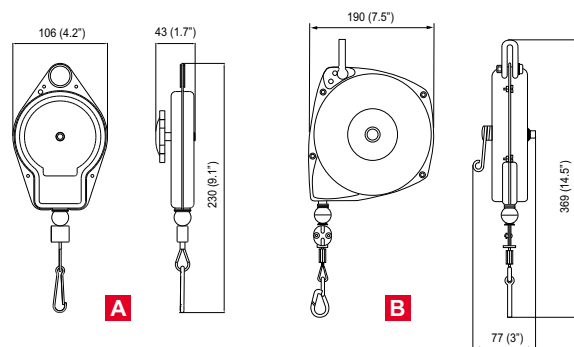

## BALANCERS - 1DU - 22S

PIC REF	MODEL	PART NUMBER	LOAD RANGE				CABLE TRAVEL		WEIGHT	
			MIN. CAPACITY		MAX. CAPACITY		m	ft	kg	lb
			kg	lb	kg	lb			kg	lb
A	1DU	52542	0	0	0.5	1.1	1.5	4.9	0.6	1.3
	2DU	50522	0.5	1.1	1.0	2.2	1.5	4.9	0.6	1.3
	2DUS	54532	0.5	1.1	1.0	2.2	3.0	9.8	0.6	1.3
	3DU	52862	1.0	2.2	1.5	3.3	1.5	4.9	0.6	1.3
	4DU	50532	1.0	2.2	2.0	4.4	1.5	4.9	0.6	1.3
B	5DU	50542	1.4	3.1	2.4	5.3	1.5	4.9	0.6	1.3
	10D	50052	2.5	5.5	5.0	11.0	2.4	7.8	2.7	6.0
	15D	50062	5.0	11.0	7.0	15.4	2.4	7.8	3.2	7.1
	22D	50072	6.0	13.2	10.0	22.0	2.4	7.8	3.2	7.1
	10S*	50572	2.0	4.4	5.0	11.0	2.4	7.8	2.7	6.0
	15S*	50582	5.0	11.0	7.0	15.4	2.4	7.8	3.2	7.1
	22S*	50592	6.0	13.2	10.0	22.0	2.4	7.8	3.2	7.1

\* Balancers with drum lock features



- Steel housing
- Additional support chain included
- Polyurethane hose
- 1/4" in. thread

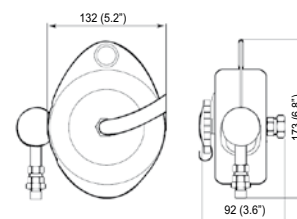

## HOSE BALANCERS - 1HU - 4HU

MODEL	PART NUMBER	LOAD RANGE				HOSE TRAVEL		HOSE ID		WEIGHT	
		MIN. CAPACITY		MAX. CAPACITY		m	ft	mm	in.	kg	lb
		kg	lb	kg	lb					kg	lb
1HU	52552			0.5	1.1	1.5	4.9	6.5	1/4	1.2	2.6
3HU	50552	0.5	1.1	1.4	3.1	1.0	3.3	6.5	1/4	1.2	2.6
4HU	50562	0.7	1.5	2.0	4.4	1.0	3.3	6.5	1/4	3.3	7.3

Flow rate: 7.1 l/s (15cfm)



- Reaction free: holds the load weightless throughout the entire cable length
- Plastic housing & nylon cable: 2R, 4R
- Steel housing & steel cable: 5R, 10R
- Cable locks in the event of spring failure

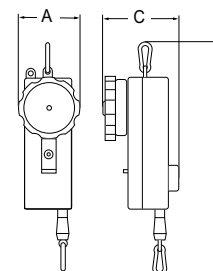

## BALANCERS - REACTION FREE SELF-LOCK - 2R - 10R

MODEL	PART NUMBER	LOAD RANGE				CABLE TRAVEL		WEIGHT		DIMENSIONS					
		MIN. CAPACITY		MAX. CAPACITY		m	ft	kg	lb	A		B		C	
		kg	lb	kg	lb					mm	in.	mm	in.	mm	in.
2R	54422	0.7	1.5	1.3	2.9	1.7	5.5	0.5	1.1	72	2.8	245	9.6	108	4.3
4R	54432	1.0	2.2	2.0	4.4	1.7	5.5	0.5	1.1	72	2.8	245	9.6	108	4.3
5R	54442	1.7	3.7	3.5	7.7	2.4	7.8	2.3	5.1	116	4.6	427	16.8	155	6.1
10R	54452	3.0	6.6	6.0	13.2	2.4	7.8	2.3	5.1	116	4.6	427	16.8	155	6.1

# Balancers - DF and DFL Series

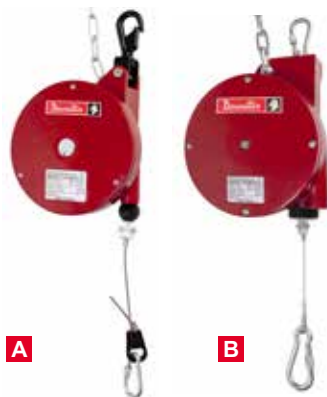

- Reaction free: holds the load weightless throughout the entire cable length
- Rigid and impact-resistant plastic housing
- 360° swiveling safety hook for isolated suspension
- Screw-type safety hook for load suspension
- Standard safety chain
- Spring fracture safeguard, integrated drum lock

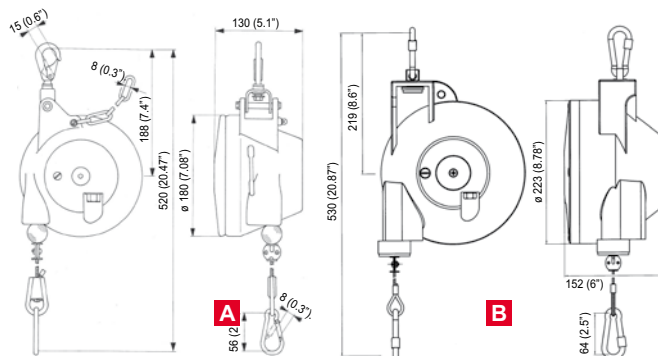

## BALANCERS - 5DF - 55 DF

PIC REF	MODEL	PART NUMBER	LOAD RANGE		CABLE TRAVEL		WEIGHT			
			MIN. CAPACITY	MAX. CAPACITY	m	ft	kg	lb		
A	5DF	615 805 011 0	3.0	6.6	5.0	11.0	2.0	6.6	2.9	6.4
	7DF	615 805 012 0	4.5	9.9	7.0	15.4	2.0	6.6	3.1	6.8
	10DF	615 805 013 0	6.0	13.2	10.0	22.0	2.0	6.6	3.2	7.1
	14DF	615 805 014 0	9.0	19.8	14.0	30.9	2.0	6.6	3.4	7.5
	17DF	615 805 015 0	13.0	28.7	17.0	37.5	2.0	6.6	3.6	7.9
B	21DF	615 805 016 0	16.0	35.3	21.0	46.3	2.0	6.6	3.8	8.4
	25DF	615 805 017 0	15.0	33.1	25.0	55.1	2.0	6.6	7.8	17.2
	35DF	615 805 018 0	25.0	55.1	35.0	77.2	2.0	6.6	8.9	16.6
	45DF	615 805 019 0	35.0	77.2	45.0	99.2	2.0	6.6	9.5	20.9
	55DF	615 805 020 0	45.0	99.2	55.0	121.2	2.0	6.6	9.7	21.4



- Reaction free: holds the load weightless throughout the entire cable length
- Rigid and impact-resistant aluminum housing
- 360° swiveling safety hook
- Cable extension limit stop for overload protection
- Screw-type safety hook for load suspension
- Standard safety chain
- Standard spring fracture safeguard integrated drum lock
- Ferrule for securing cable end
- Freewheel device for protection against handling errors

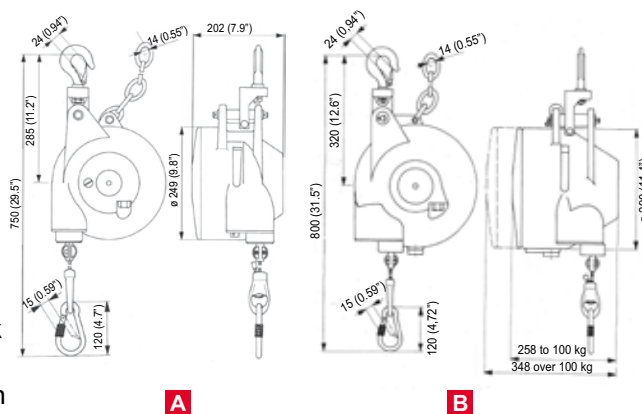

## BALANCERS - 20DFL - 200DFL

PIC REF	MODEL	PART NUMBER	LOAD RANGE		CABLE TRAVEL		WEIGHT			
			MIN. CAPACITY	MAX. CAPACITY	m	ft	kg	lb		
A	20DFL	615 805 021 0	12	26.5	20	44.1	2.0	6.6	14.8	32.6
	30DFL	615 805 022 0	20	44.1	30	66.1	2.0	6.6	15.2	33.5
	45DFL	615 805 023 0	30	66.1	45	99.2	2.0	6.6	16.9	37.2
	60DFL	615 805 024 0	45	99.2	60	132.3	2.0	6.6	17.3	38.1
	75DFL	615 805 025 0	60	132.3	75	165.3	2.0	6.6	18.7	41.2
	90DFL	615 805 026 0	75	165.3	90	198.4	2.0	6.6	19.7	43.4
	100DFL	615 805 027 0	90	198.4	100	220.4	2.0	6.6	20.9	46.1
	115DFL	615 805 028 0	100	220.4	115	253.5	3.0	9.8	41.8	92.1
	130DFL	615 805 029 0	115	253.5	130	286.6	3.0	9.8	43.2	95.2
	B	140DFL	615 805 030 0	130	286.6	140	308.6	3.0	9.8	44.6
150DFL		615 805 031 0	140	308.6	150	330.7	3.0	9.8	46.0	101.4
170DFL		615 805 032 0	150	330.7	170	374.8	3.0	9.8	46.4	102.3
180DFL		615 805 033 0	170	374.8	180	396.8	3.0	9.8	46.7	102.9
190DFL		615 805 034 0	180	396.8	190	418.9	3.0	9.8	47.0	103.6
200DFL		615 805 035 0	190	418.9	200	440.9	3.0	9.8	47.3	104.2

# Tool holster

Keep your tool at reach



- Adapted for all straight or pistol grip tools with an outside diameter of maximum 42 mm

The mounting plate can be fastened in several positions and the plastic ring angle can be set at different angles

PART NUMBER	DESCRIPTION	MAX. DIAMETER	
		mm	in.
107 892	DTH-42	42	1.65

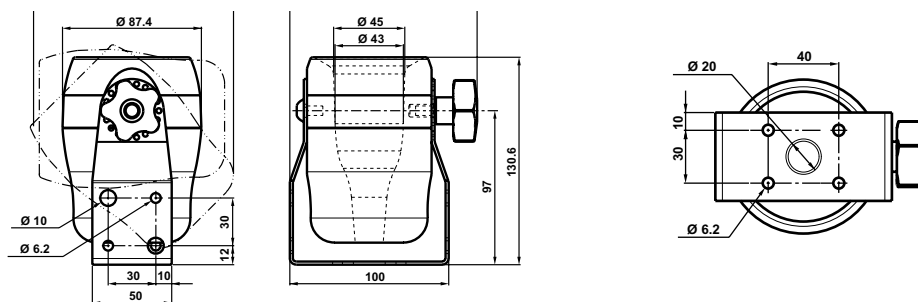

# Air-Flex: the 360 degrees air fitting

Air-Flex makes all rigid hoses flexible and multi-directional

To be connected directly at the tool air inlet  
 Easy: less effort due to hose rigidity, makes work easier in hard to reach areas  
 Comfort and safety: no twisting, the hose remains in the ideal working position and lowers the risk of tendinitis  
 Less wear: no more premature hose wear



Anti-marking Air-Flex with rubber cover

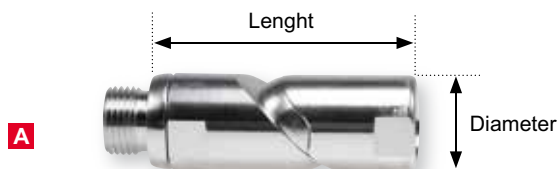

PIC REF	MODEL	PART NUMBER	MAX RECOMMENDED AIR FLOW		FEMALE INLET	MALE OUTLET	WEIGHT		LENGTH		OUTSIDE DIAMETER	
			l/s	cfm	in.	in.	g	lb	mm	in.	mm	in.
	AIR-FLEX 1/4" BSP	615 804 746 0	12	25	1/4 BSP	1/4 BSP	79	0.17	67	2.63	24.0	0.94
	AIR-FLEX 3/8" BSP	615 804 748 0	35	74	3/8 BSP	3/8 BSP	126	0.28	82	3.23	29.5	1.16
A	AIR-FLEX 1/2" BSP	615 804 750 0	35	74	1/2 BSP	1/2 BSP	132	0.29	82	3.23	29.5	1.16
	AIR-FLEX 1/4" NPT	615 804 747 0	12	25	1/4 NPT	1/4 NPT	79	0.17	67	2.63	24.0	0.94
	AIR-FLEX 3/8" NPT	615 804 749 0	35	74	3/8 NPT	3/8 NPT	126	0.28	82	3.23	29.5	1.16
	AIR-FLEX 1/2" NPT	615 804 751 0	35	74	1/2 NPT	1/2 NPT	132	0.29	82	3.23	29.5	1.16
B	AIR-FLEX 1/4 BSP A/M	615 810 046 0	12	25	1/4 BSP	1/4 BSP	82	0.18	67	2.63	24.0	0.94

Pressure drop of 0,2 bar at nominal pressure of 6 bar

# Automatic Screw Dispenser

## Boost your productivity and efficiency

### To be used for the assembly of:

- Electronics: TV, mobile phones, computers
- Medical products
- Small appliances

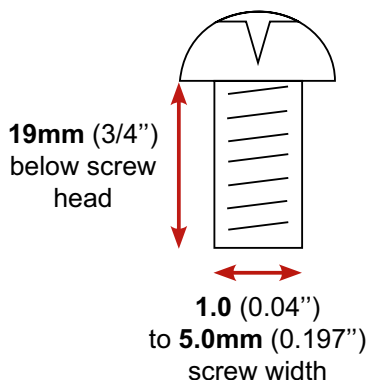

- **Widest range of screw sizes:** between 1.0 (0.04") and 5.0mm (0.197") thread diameters (about 11 different screw sizes) including screws with captive washers and up to 19mm (3/4") screw length (under head)
- **Complete:** supplied with universal feeding rail to avoid buying additional and expensive spare rails
- **Fully adjustable:** vibration time, vibration intensity, and drum rotation time adjustments allow the user to optimize the screw feed rate
- **Quiet operation & easy to service**
- Includes: rail adjustment kit, AC adapter and ground wire

PART NUMBER	POWER PLUG	SCREW RANGE			RAIL ADJUSTMENT KIT	DIMENSIONS						POWER
		SIZE	LENGTH			L	H		W			
			mm	in.	m	mm	in.	mm	in.	mm	in.	
615 810 472 0	UK	M1.0 to M5.0	Up	Up	included	126	5	147	5.8	182	7.2	AC 100
615 810 473 0	EUR	M1.0 to M5.0	to 19	to 3/4								~
615 810 474 0	US	0.04" to 0.197"	(under head)	(under head)								240V

# More Than Productivity



[www.desouttertools.com](http://www.desouttertools.com)