



**Industrial**<sup>Tools</sup>

Part no 371843  
Issue no 02  
Series -  
Date 02/2013

**AIR MOTORS - HM SERIES**

HM-340	1304314
HM-500	1305964
HM-830	1305884

- (GB) Servicing Instructions
- (GB) Operating Instructions
- (GB) Parts List
- (D) Wartungsanleitung
- (D) Bedienungsanleitung
- (D) Teileliste
- (F) Manuel d'entretien
- (F) Manuel d'utilisation
- (F) Liste de pièces
- (E) Instrucciones de Servicio
- (E) Instrucciones de Operación
- (E) Listas de Repuestos
- (E) Instruções de Manutenção
- (P) Instruções de Funcionamento
- (P) Listas de Peças
- (I) Istruzioni per la Manutenzione
- (I) Istruzioni Operative
- (I) Elenco delle Parti

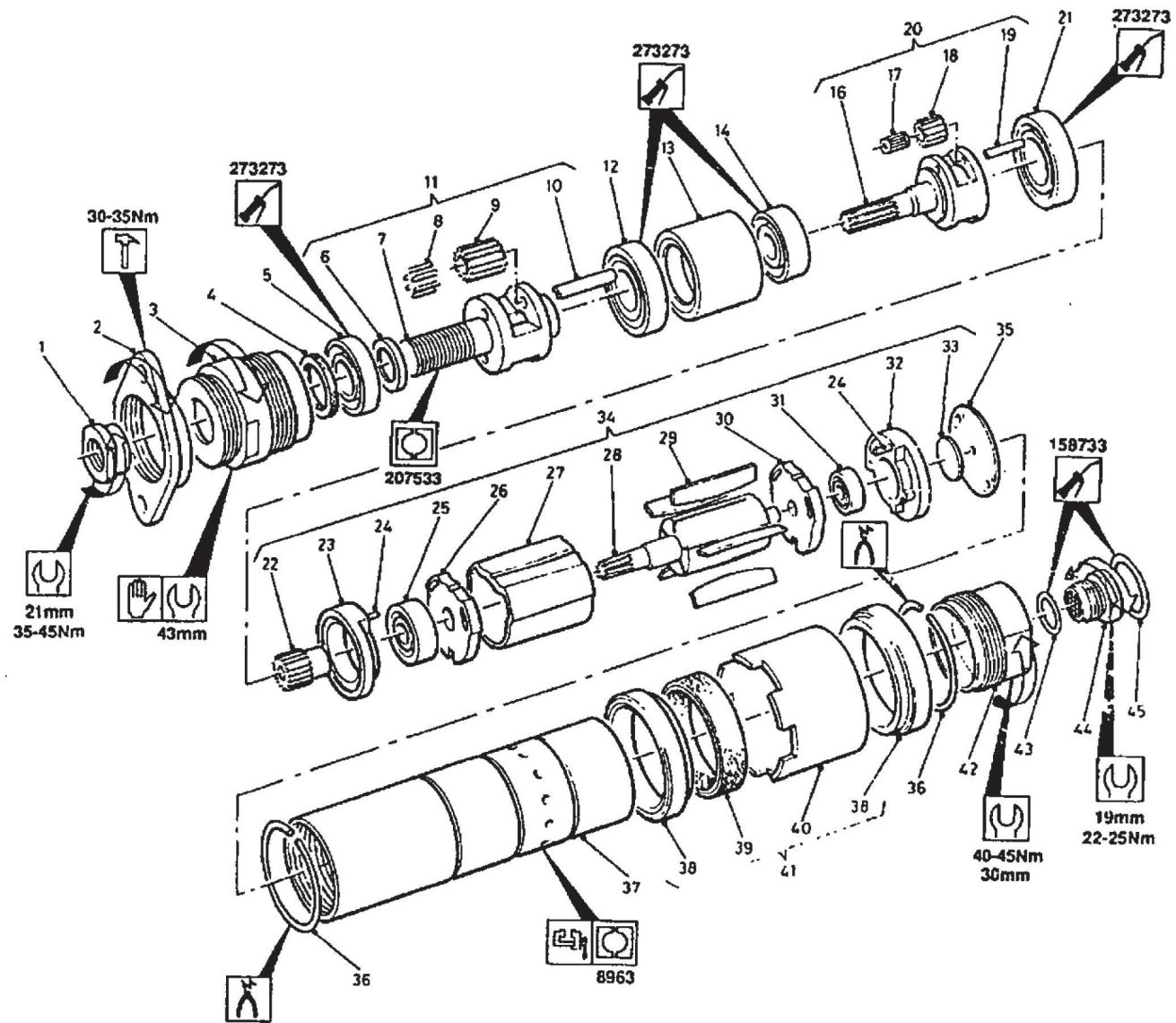

Item No. Pos.Nr. No. Article	Part No. Teil. No. Référence	Qty Menge Qté	Item No. Pos.Nr. No. Article	Part No. Teil. No. Référence	Qty Menge Qté
1	26593	1	* 21	1483	1
2	25893	1		(HM-830)	
3	25763	1	-	1673	1
* 4	25843	1		(HM-340,-500)	
* 5	25863	1	22	273873	1
6	26223	1		(HM-830)	
7	26583	1	23	265063	1
* 8	25963	20	24	266183	1
9	25263	2	* 25	80253	1
10	25953	2	26	265043	1
11	28753	1	27	265033	1
* 12	1673	1	28	265113	1
13	5643	1		(HM-830)	
-	(HM-340,-830)		-	265103	1
-	5303	1		(HM-500)	
-	(HM-500)		-	265093	1
* 14	9908	1		(HM-340)	
16	27413	1	* 31	500693	1
-	(HM-830)		32	265073	1
-	25773	1	33	256773	1
-	(HM-340,-500)		34	273853	1
* 17	502093	2		(HM-830)	
-	(HM-830)		-	271823	1
-	502103	2		(HM-500)	
-	(M-340,-500)		-	271783	1
18	49703	1		(HM-340)	
-	(M-830)		35	275433	1
-	80003	2	36	28663	2
-	(HM-500)		37	25793	1
-	1353	2	38	500303	2
-	(HM-830)		39	203473	1
19	1453	2	40	500303	1
-	(HM-830)		41	277703	1
-	80013	2	42	264603	1
-	(HM-340,-500)		* 43	89853	1
20	158963	1	44	42953 (BSP)	1
-	(HM-860)		-	47133 (NPT)	1
-	27123	1	* 46	37233	1
-	(HM-500)				
-	25933	1			
-	(HM-340)				
-	(HM-340)				

\* Indicates normal replacement items. It is recommended that adequate stocks are held for servicing requirements.

Always quote tool model number, serial number and spare part number when ordering spares.

\* Bedeutet normale Verschleißteile. Es empfiehlt sich eine angemessene Menge für Wartungszwecke auf Lager zu halten.

Bei der Bestellung von Ersatzteilen, bitte immer angeben: Typennummer der Bohrmaschine, Werknummer und Ersatzteilnummer.

\* Le symbole astérisque (\*) indique des articles de rechange normal. Il est recommandé d'en conserver de stocks suffisants pour assurer toutes les opérations d'entretien courant.

Lors de la commande de pièces de rechange, toujours citer le numéro de modèle de l'outillage, son numéro de série et le numéro de référence de chaque pièce de rechange.

\* Indica elementos de reposición regular. Se recomienda tener una cantidad adecuada de los mismos en reserva a efectos de mantenimiento.

Al encarga piezas de recambio, siempre debe indicarse el número de modelo de la herramienta, su número de serie y el número de la pieza de recambio.

\* Indica itens que são substituídos regularmente. É recomendado que estoques adequados sejam mantidos para requisitos de manutenção.

Cite sempre o número do modelo da ferramenta, número de série, e número da peça acessória quando pedindo acessórios.

\* L'asterisco denota ricambi normali. Si consiglia di mantenere scorte adeguate alle esigenze della manutenzione.

Nell'ordinazione di ricambi citari il numero di modello dell'utensile, il numero di matricola e quello di catalogo del pezzo.

**STATEMENT OF USE**

This motor is designed to be incorporated into a fixed or moving machine. It is for right hand rotation and should be mounted by the flange or threaded nose only. The risk of the motors being the source of ignition of a potentially explosive atmosphere is extremely small. The user is responsible for assessing the risks associated with the whole machine into which the motor is to be incorporated.

**GENERAL**

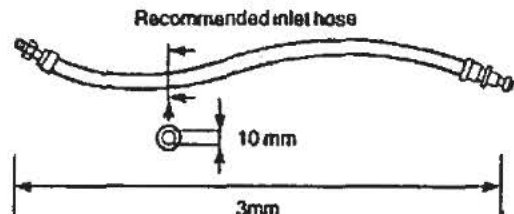

**LUBRICATION**

Correct lubrication is vital for the maximum performance of the tool and an airline lubricator should be fitted into the system down stream of the filter. Use ISO VG15.

158733 = Molykote PG75	273283 = BP FG00EP
208893 = Rocol M204G	27662(5L) = ISO VG15
273273 = BP Q5818	27652(250ml) = ISO VG15

**DATA**

Maximum air pressure Pmax	= 6.3 bar
Minimum air pressure Pmin	= 2 bar
Sound pressure level (dBA)	= 82 re.CAGI-PNEUROP Test code
Vibration level (m/s <sup>2</sup> )	= <2.5 re.ISO 8662

**WEIGHT**

Motor type/RPM	kg
HM 340	1.6
HM 500	1.6
HM 830	1.6

**ACCESSORIES**

A range of accessories are available and suitable items should be selected from the Desoutter accessories catalogue.

**MAINTENANCE INSTRUCTIONS**

1. Servicing should be carried out at intervals of 1000 hours use.
2. All torque figures  $\pm 10\%$ .
3. Replace as necessary all 'O' rings, bearings and rotor blades, see service kits.
4.  Indicates direction of dismantling.
5. When disposing of components, lubricants, etc. ensure that the relevant safety procedures are carried out.

To Assemble: Motor complete, refer to main illustration

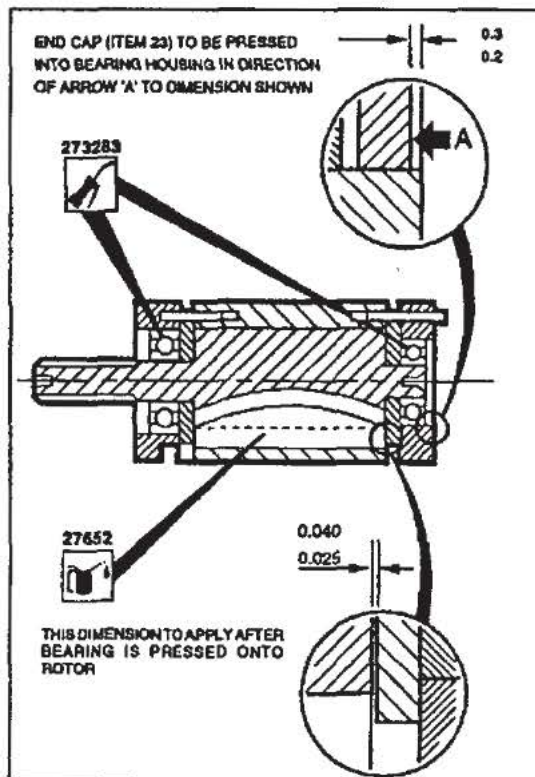
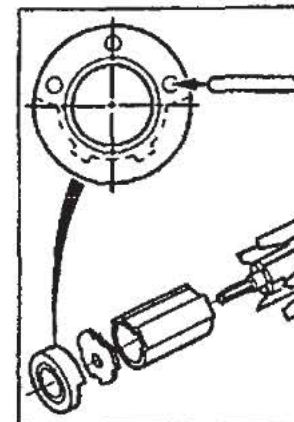

## VERWENUNGSZWECK

Dieser Motor ist zum Einbau in feststehende oder bewegliche Maschinen gedacht. Er ist rechtsdrehend und darf nur am Flansch oder Gewindeansatz montiert werden. Das Risiko, daß der Motor zur Entzündung einer potentiell explosiven Atmosphäre führen könnte, ist äußerst gering. Der Benutzer trägt die Verantwortung für eine Beurteilung der Risiken für die gesamte Maschine, in die der Motor eingebaut werden soll.

## ALLGEMEIN

Empfohlener Einführungsschlauch

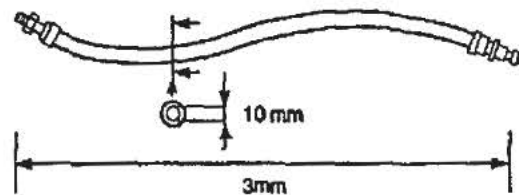

## SCHMIERUNG

Korrekte Schmierung ist zur Gewährleistung maximaler Werkzeugleistung unbedingt notwendig; eine Luftleitungs-Schmiervorrichtung sollte in Strömungsrichtung der Filter eingebaut werden. ISO VG15 benutzen.

158733 = Molykote PG75	273283 = BP FG00EP
208893 = Rocol M204G	27662(5L) = ISO VG15
273273 = BP Q5618	27652(250ml) = ISO VG15

## DATEN

Max. Luftdruck P <sub>max</sub>	= 6,3 bar
Min. Luftdruck P <sub>min</sub>	= 2 bar
Schalldruck (dBa)	= 62 re. CAGI-PNEUROP Test code
Schwingungsstärke (m/sec <sup>2</sup> )	= <2.5 re. ISO 8862

## GEWICHT

Motor type/RPM	kg
HM 340	1.8
HM 500	1.8
HM 600	1.8

## ZUBEHÖR

Eine Reihe von Zubehörtteilen steht zur Verfügung. Geeignete sind aus dem Desoutter-Katalog auszuwählen.

## WARTUNGSANLEITUNGEN

1. Wartung ist in Abständen von 1000 Stunden Benutzung durchzuführen.
2. Sämtliche Drehmomentzahlen  $\pm 10\%$ .
3. Sämtliche O-Ringe, Lager und Rotorblätter je nach Bedarf auswechseln - siehe Wartungsausrüstung.
4.  Zeigt Demontagerichtung.
5. Bei der Entsorgung von Teilen, Schmiermitteln, usw. dafür sorgen, daß die entsprechenden Sicherheitsvorkehrungen getroffen werden.

Montieren: kompletter Motor - siehe Hauptabbildung

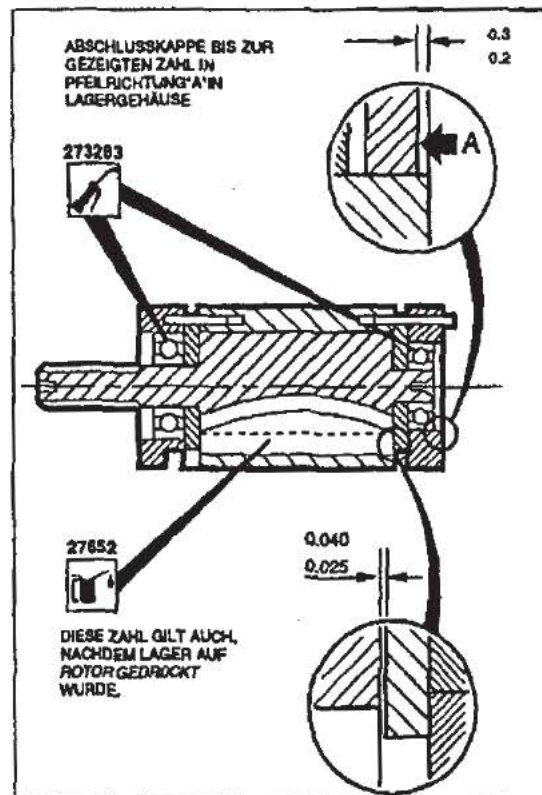
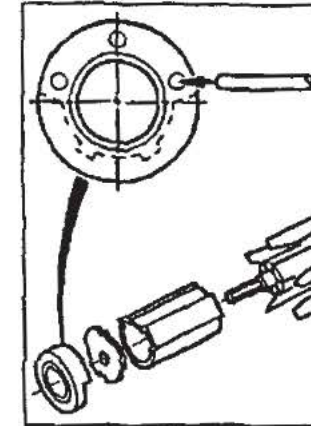

### DECLARATION D'UTILISATION

Ce moteur est conçu pour être incorporé à une machine fixe ou mobile.  
 Il est destiné à une rotation à droite et son montage devra être uniquement à plateau ou à nez fileté. Le risque que les moteurs forment une source d'ignition dans une atmosphère potentiellement explosive est extrêmement réduit.  
 L'utilisateur a la responsabilité de l'appréciation des risques relatifs à la machine toute entière, dans laquelle ce moteur doit être incorporé.

### GENERALITES

Câble d'alimentation recommandé

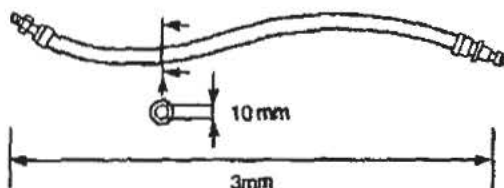

### LUBRIFICATION

Une lubrification appropriée est essentielle à la performance optimale de l'outil, et un graisseur à prise d'air devra être monté dans le système en aval des filtres. Utilisez ISO VG15.

158733 = Molykote PG75	273283 = BP FG00EP
206893 = Rocol M204G	27682(5L) = ISO VG15
273273 = BP Q5618	27652(250ml) = ISO VG15

### DONNÉES TECHNIQUES

Pression Pneumatique maximale Pmax	= 6,3 bars
Pression Pneumatique minimale Pmin	= 2 bars
Niveau de Pression du Son (dBA)	= 82 rb. CAGI-PNEUROP Test code
Niveau de Vibration (m/sec <sup>2</sup> )	= <2.5 re. ISO 8662

### POIDS

Motor type/RPM	kg
HM 340	1.6
HM 500	1.6
HM 830	1.6

### ACCESSOIRES

Une gamme d'accessoires est disponible et les pièces appropriées devront être sélectionnées dans le catalogue Desoutter.

### INSTRUCTIONS D'ENTRETIEN

1. L'entretien devra être effectué à des intervalles d'utilisation de 1000 heures.
2. Toutes les valeurs de moments sont à ± 10%.
3. Remplacer au besoin tous les Joints O, les roulements, les lames de rotors, voir Kits d'Entretien.
4.  Indique la direction du démontage.
5. Pour la mise au rebut de pièces, lubrifiants etc, s'assurer que les procédures de sécurité en vigueur sont appliquées.

Pour le Montage: Moteur assemblé, se référer à l'illustration principe

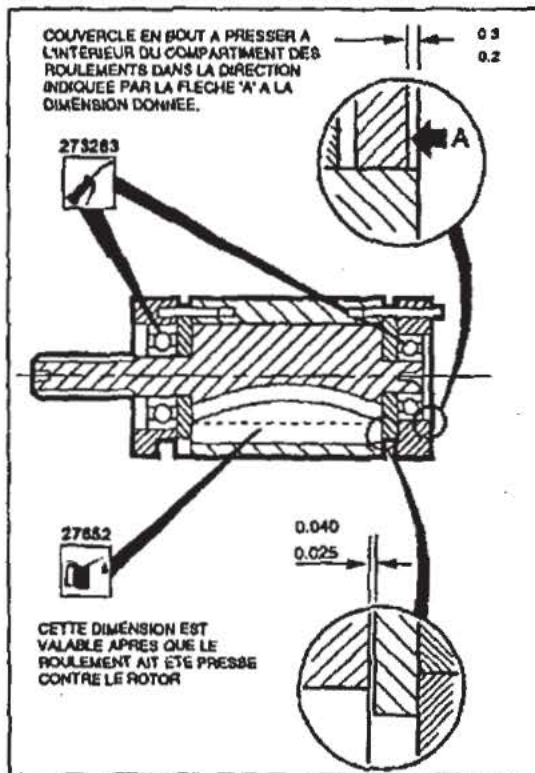
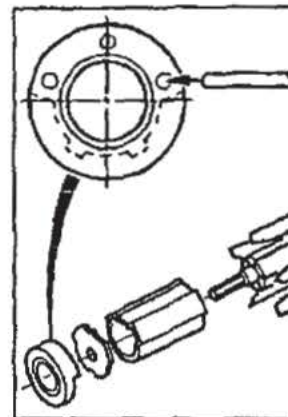

## MANIFESTACION DE USO

Este motor está diseñado para su incorporación en una máquina fija o no.

Es para rotación a la derecha y solamente se debe montar por su brida o cabeza roscada. El riesgo de que los motores sean el punto de ignición en una atmósfera potencialmente explosiva es extremadamente pequeño. El usuario se responsabilizará de evaluar los riesgos asociados con la máquina entera, la cual incorpora el motor.

## GENERAL

Manguera de acometida recomendada

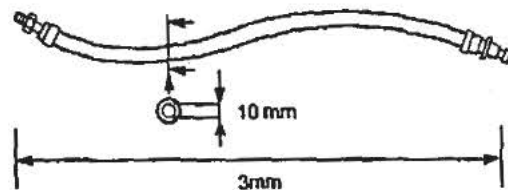

## LUBRICACION

La correcta lubricación es vital para obtener el máximo rendimiento de la herramienta debiéndose instalar en la línea de aire un lubricador después de los filtros. Usar ISO VG15.

158733 = Molykote PG75	273283	= BP FG00EP
208893 = Rocol M204G	27662(5L)	= ISO VG15
273273 = BP Q5618	27652(250ml)	= ISO VG15

## DATOS

Presión máxima de aire Pmax	= 6.3 bar
Presión mínima de aire Pmin	= 2 bar
Nivel de presión de sonido (dBA)	= 82 re. CAGI-PNEUROP Código de ensayo
Nivel de vibración (m/sec <sup>2</sup> )	= <2,5 re. ISO 8662

## PESO

Motor type/RPM	kg
HM 340	1.8
HM 500	1.8
HM 830	1.8

## ACCESORIOS

Una amplia gama de accesorios son disponibles y artículos apropiados se podrán escoger del catálogo de accesorios de DESOUTTER.

## INSTRUCCIONES DE MANTENIMIENTO

1. Las revisiones se deben llevar a cabo a intervalos de 1000 horas de uso.
2. Los valores de par son  $\pm 10\%$ .
3. Cuando sea necesario, reemplazar los sellos, rodamientos y las aletas del motor. Remitir a kits de revisión.
4.  Indica la dirección del desmontaje.
5. Asegurarse que los procedimientos de seguridad son efectuados al deshacer de componentes, lubricantes etc.

Pour le Montage: Moteur assemblé, se référer à l'illustration principe

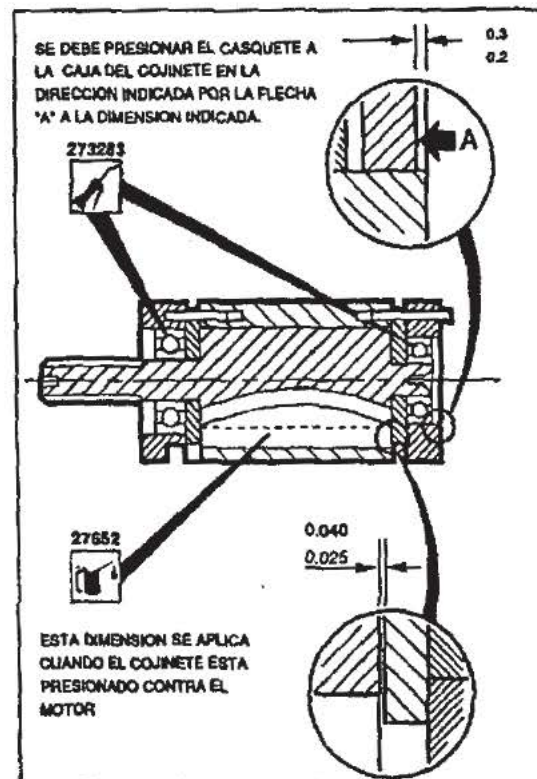
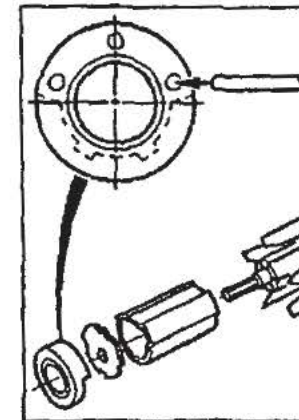

### INDICAÇÕES PARA UTILIZAÇÃO

Este motor é concebido para ser incorporado numa máquina fixa ou móvel.

O motor é para rotação à direita e deve ser montado apenas pela flange ou pela ponta rosçada. O risco de estes motores constituírem uma fonte de ignição numa atmosfera potencialmente explosiva é extremamente pequeno.

O utilizador é responsável por avaliar os riscos associados à máquina completa, na qual motor vai ser incorporado.

### GERAL

Mangueira de admissão recomendada

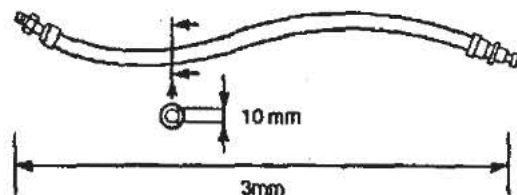

### LUBRIFICAÇÃO

A lubrificação correcta é imprescindível para o desempenho máximo da ferramenta, e deve ser instalado um lubrificador de linha de arno sistema e jante dos filtros. Utilize ISO VG 15.

158733 = Molykote PG75	273283 = BP FG00EP
208893 = Focol M204G	27662(5L) = ISO VG15
273273 = BP Q5618	27652(250ml) = ISO VG15

### DADOS

Pressão máxima do ar Pmax	= 6,3 bar
Pressão mínima do ar Pmin	= 2 bar
Nível de pressão de som(dBA)	= 82 re. CAGI-PUNEUROP
	Código ensaio
Nível de vibração (m/sec <sup>2</sup> )	= <2.5 re. ISO 8662

### PESO

Motor type/RPM	kg
HM 340	1.6
HM 500	1.6
HM 830	1.6

### ACESÓRIOS

Está disponível uma gama de acessórios, os artigos adequados devem ser seleccionados no Catálogo Desoutter.

### INSTRUÇÕES PARA MANUTENÇÃO

1. Deve ser feita manutenção a intervalos de 1000 horas de utilização.
2. Todos os valores de binário  $\pm 10\%$ .
3. Substitua todos os "O" rings, rolamentos e lâminas do rotor conforme for necessário - ver Kits de Manutenção.
4.  Indica la dirección de desmontagem.
5. Ao descartar componentes, lubrificantes etc... certifique-se de que os procedimentos de segurança relevantes são observados.

Para Montar: Consulte a ilustração principal

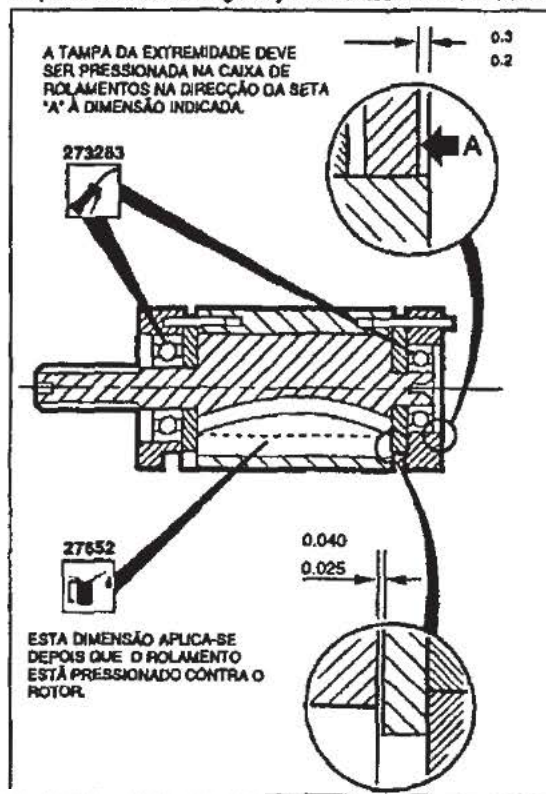
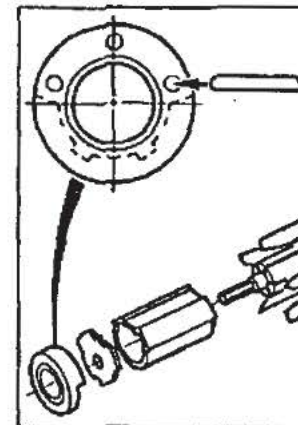





## DICHIARAZIONE DELL'USO

Il progetto e la costruzione di questo motore lo rendono adatto a essere incorporato in macchine sia stazionarie che mobili.

Il motore è costruito per la rotazione in senso destrorso e deve essere fissato solo a mezzo dell'apposita flangia o a mezzo del nasello filettato. Il motore comporta un rischio estremamente basso di accensione in un'atmosfera potenzialmente esplosiva.

E' responsabilità dell'utente di valutare i rischi relativi all'insieme totale della macchina nella quale il motore sarà incorporato.

## GENERALITA'

Attacco consigliato del tubo flessibile di entrata

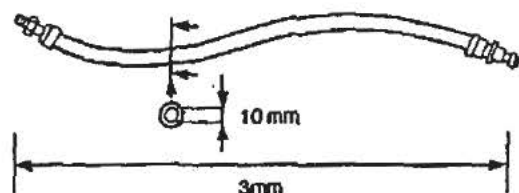

## LUBRIFICAZIONE

La corretta lubrificazione è vitale per la massima prestazione dell'attrezzo e un lubrificatore della linea aria dovrebbe essere inserito nel sistema a valle dei filtri. Usare ISO VG15.

158733 = Molykote PG75	273283 = BP FG00EP
208693 = Focol M204G	27662(SL) = ISO VG15
273273 = BP Q5618	27652(250ml) = ISO VG15

## DATI

Massima pressione dell'aria Pmax	= 6,3 bar
Massima pressione dell'aria	= 2 bar
Livello pressione sonora (dBa)	= 82 rif. CAGI-PNEUROP codice di prova
Livello di vibrazione (m/sec <sup>2</sup> )	= <2.5 rif. ISO 8662

## PESO

Motor type/RPM	kg
HM 340	1,8
HM 500	1,8
HM 830	1,8

## ACCESSORI

E' disponibile una gamma di accessori, si scelga perciò l'articolo adatto dal catalogo di Accessori Desoutter.

## ISTRUZIONI PER LA MANUTENZIONE

1. Il servizio di manutenzione dovrebbe essere eseguito ogni 1000 ore di uso.
2. Tutti i valori di coppia indicati  $\pm 10\%$ .
3. Quando sia necessario, sostituire tutti gli anelli 'O', i cuscinetti, le pale del rotore - vedere i Kit di Servizio.



Indica la direzione di smontaggio.

5. Quando si eliminano componenti, lubrificanti ecc., assicurarsi che le relative procedure di sicurezza siano osservate.

Assemblaggio: Motore completo-riferirsi all'illustrazione principale

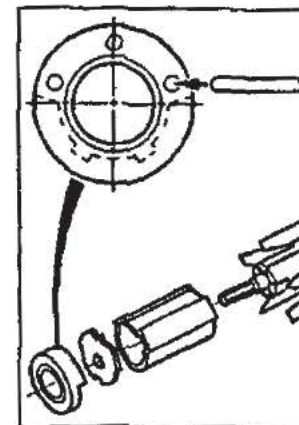

IL COPERCHIO D'ESTREMITA' DEVE ESSERE SPINTO NELL'ALLOGGIAMENTO DEL CUSCINETTO NELLA DIREZIONE DELLA FRECCIA 'A' FINO ALLA DIMENSIONE INDICATA

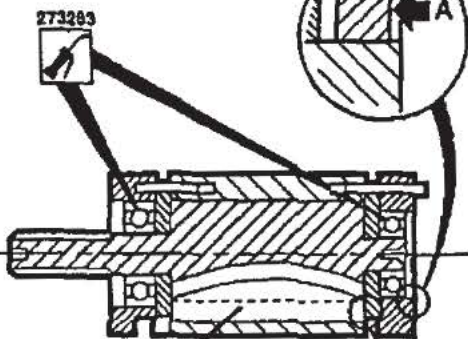

QUESTA DIMENSIONE E' APPLICABILE DOPO CHE IL CUSCINETTO E' STATO SPINTO SUL ROTORE

0.040  
0.025

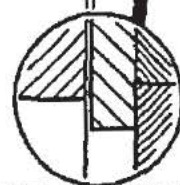

Zampini Industrial Group

Industrial Air & Electric Tools

We Sell Reliability!

In Business Since 1987

FREE Expert Assistance - Call Now

ZAMPINI INDUSTRIAL GROUP

AirToolPro.com

1-800-353-4676

Desoutter

