



Quality Control Measurement Systems

*Optimize Tool Performance
Reduce Quality Cost
Full Data Traceability
Integrated Software Solution*

More Than Productivity

Industrial Tools



DATA ANALYZER

This generation of Delta analyzer is the compact portable solution to monitor all types of production tools at just 500g. Combined with standard Desoutter DRT or DST transducers it's capable of calibrating pulse tools, electric nutrunners or torque wrenches. Divided into three models for Torque measurement only (DELTA 1D), Torque & Angle (Delta 6D) and capable of residual torque check and production strategy with DWTA wrench (Delta 7D).



- Display Large color screen shows clear test results, Torque&Angle curves. Real time statistics, Tools description and Routes.

>> MAIN FUNCTION

TRANSDUCER	DELTA 1D	DELTA 6D	DELTA 7D
Connection to DRT4, DRT5, DST	✓	✓	✓
Connection to DWT, DWTA			✓
Connection to CMD and GSE type	✓	✓	✓
	Through optional analog/digital adapter		
ON BOARD FUNCTIONALITY	DELTA 1D	DELTA 6D	DELTA 7D
Wrench Test	✓	✓	✓
Nutrunner Test	✓	✓	✓
Pulse Tool Test	✓	✓	✓
Tools	1	1000	1000
PSet		1000	1000
Integrated Statistic	Min, Max Avg	Cm, Cmk (ISO, NF and CNOMO standards)	Cm, Cmk (ISO, NF and CNOMO standards) + SPC
Residual Check Strategy			✓
Production Strategy			✓
Results	1000	5000	5000
Curve	10	10	10
CVI autocalibration		✓	✓
External Barcode connectivity		✓	✓
Embedded Barcode			✓

Delta

>> MAIN FEATURES

- Connectivity
Ethernet and USB port for Delta QC software communication and RS232 for CVI II, CVIC II and CVI3 calibration or barcode reader.



- Transducer
Standard Desoutter connector for digital transducers. Analog CMD and GSE transducer connection through an adapter.



- Power
Li-Ion high capacity battery of 16 hours of autonomy or external power supply.



- Barcode (Delta 7D)
Embedded Barcode for automatic Pset selection or VIN traceability

Delta 1D



DELTA 1D is a torque measurement ideal for torque wrench or pulse tool test together with DRT or DST transducers. Delta 1D doesn't require any programming, it's ready to test the selected tool showing in real time Mins, Max and Average. Complete results and XLS reports are available to be exported from Delta QC Free version software.

Delta 6D



DELTA 6D reads Angle from DRT transducer, ideal to test advanced electric nutrunner T&A strategies. DELTA 6D introduces Tool and PSet and definition with Route management, Statistic (ISO, CNOMO or NF standards), Curve and serial communication to CVI controller or Barcode. SPC analysis, curve overlay and off-line programming are available in combination with Delta QC Licensed version.

Delta 7D



DELTA 7D combines all DELTA 6D features with DWTA wrench communication for Residual Torque check and production available with Torque plus Angle strategy. Thanks to the new joint analysis strategy the Delta 7D in combination with DWTA becomes the perfect measurement instrument to characterise the real joint in the line, a key feature to:

- find real joint yield point
- set the production tightening tool with the correct torque and angle values increasing the quality in the overall production process.

MODEL	PART NUMBER	BATTERY hours	CHARGER volts	DEPTH		WIDTH		HEIGHT		WEIGHT	
				mm	in	mm	in	mm	in	kg	lb
Delta 1D	615 935 101 0	16	110/240V	45	1.77	95	3.74	192	7.56	0.5	1.10
Delta 6D	615 935 102 0	16	110/240V	45	1.77	95	3.74	192	7.56	0.5	1.10
Delta 7D	615 935 147 0	16	110/240V	45	1.77	95	3.74	192	7.56	0.5	1.10

>> ACCESSORIES >> Standard & Optional

DESCRIPTION	PART NO	DESCRIPTION	PART NO	DESCRIPTION	PART NO
Delta Battery	615 936 142 0	CMD 5000 Adapter	615 917 672 0*	Delta Demo Case (Empty)	615 936 140 0
Universal Power Supplier	615 936 143 0	RS232 Adapter	615 917 670 0*	DeltaQC Licensed 1 User	615 927 651 0
		GSE 2500 Adapter	615 917 674 0*	DeltaQC Licensed 5 Users	615 927 652 0
Rubber Protection	615 936 141 0	GSE 8500T Adapter	615 917 675 0*	DeltaQC Advanced 1 User	615 927 653 0
CMD & ST 4000 Adapter	615 917 671 0	GSE 8500T/A Adapter	615 917 676 0*	DeltaQC Advanced 5 Users	615 927 654 0

Digital Wrench for Torque & Angle Measurement

PRODUCTION & QUALITY STRATEGIES: In combination with Delta 7D, the torque and angle wrench for residual automatic torque check and Joint analysis with Yield point detection.

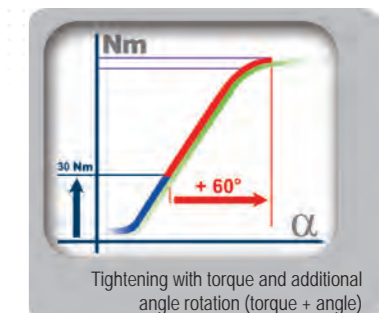
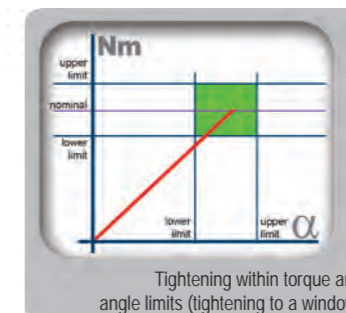
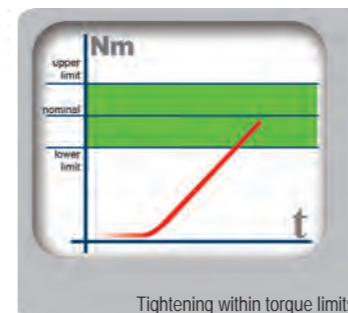

- Non Length Dependent Transducer thanks to double bridge strain gauge. To guarantee a tightening result independent from operator hand position
- 1% of torque reading (from 10% to 100% of torque range)

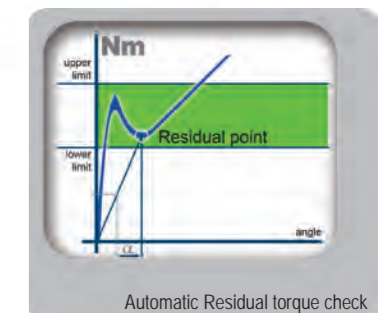

■ Delta7D

■ Military connector for standard transducer cable



■ Gyroscope for angle measurement.

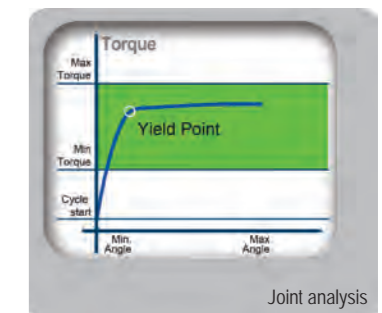

MODEL	PART NUMBER	RANGE		ANGLE	DRIVE		INCLUDED RATCHET	LENGTH		WEIGHT	
		Nm	ft lb		mm	in.		mm	in.	kg	lb
DWTA 30	615 165 760 0	3-30	2.21	✓	9x12	0.35x0.47	3/8	402	15.83	0.9	2.0
DWTA 150	615 165 761 0	15-150	11.06-110.6	✓	14x18	0.55x0.71	1/2	625	24.60	1.8	4.0
DWTA 400	615 165 762 0	40-400	29.50-295.0	✓	14x18	0.55x0.71	3/4	1026	40.40	2.8	6.2
DWTA 800	615 165 763 0	80-800	59.00-590.0	✓	Ø28	Ø1.1	1	1309	51.54	4.7	10.4

DIGITAL WRENCH FOR TORQUE & ANGLE MEASUREMENT

Delta Wrench Vision

The digital wrench integrates is a unique device and flexible solution for both production and quality strategy in tightening. Delta Wrench provides high accuracy solution for torque controlled joints tightening. Delta Wrench ensures perfect tightening operator independent thanks to automatic PSet selection and double bridge transducer, also introduces a quality strategy with angle measurement and traceability for a perfect quality audit.



■ Standard interchangeable heads



■ Intelligent RFI-TAG for PSet automatic selection



■ Double bridge Transducer

■ Embedded high capacity Li-Ion battery

■ Ergonomic keyboard to recall the predefined PSet



■ Battery Li-Ion Battery and Battery charger



■ USB Port for DELTA QC free software communication for programming 10 predefined PSet or to Export result in XLS report.

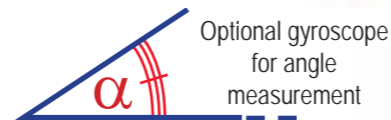

Optional gyroscope for angle measurement



■ Backlight RGB colour display for operator guidance plus acoustic buzzer

■ Optional Wireless Communication

Non Length Dependent Transducer thanks to double bridge strain gauge. To guarantee a tightening result independent from operator hand position.

1% of torque accuracy across the range

Production Strategies

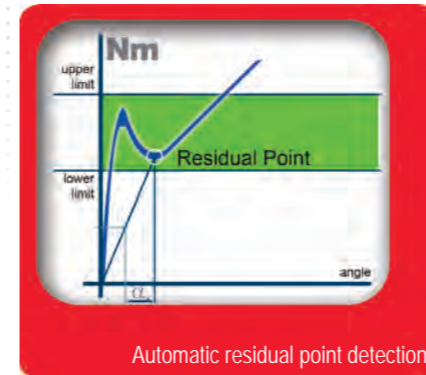
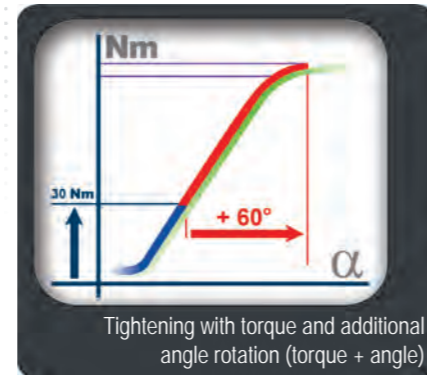
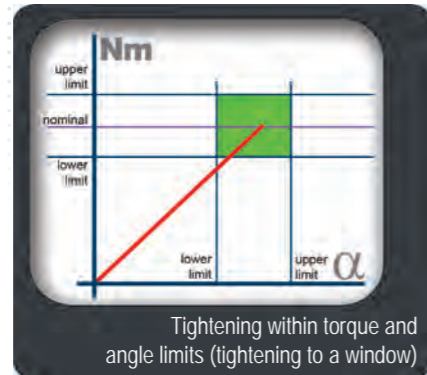
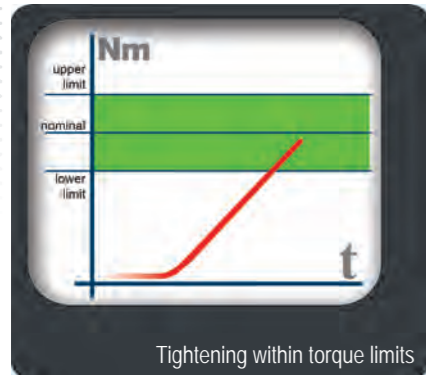

Quality Strategies

Perfect for joint inspection and auditing Delta Wrench detects automatically the real residual torque of the fastener.

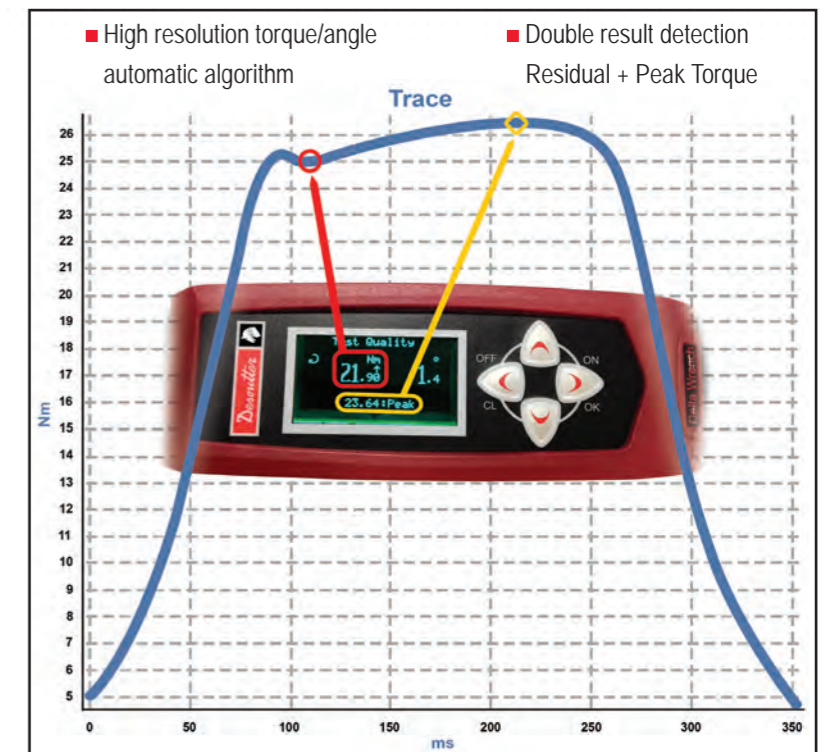

>> BENEFITS

- Accuracy for critical tightenings
- Wide torque range to replace click wrenches
- Production data traceability
- Repair station fastening capability
- Difficult access joints tightening
- Re-hit detection
- Low calibration cost
- Back up tool

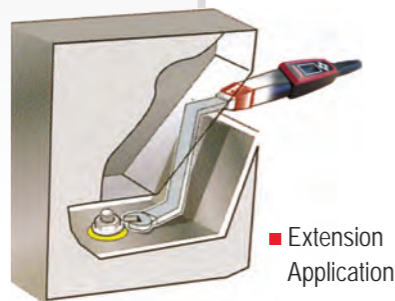

■ Open End Application



>> BENEFITS

- Real residual torque value without any special programming or setting from operator
- Save time no PC setting are required
- No risk to release an over loaded fastener as mean value is saved
- Residual value operator independent
- Export data for quality & statistic analysis
- Perfect for fast & accurate pulse tools setting



>> TECHNICAL SPECIFICATION

	DESCRIPTION
10 predefined Pset	Pset with T/A limits defined by Delta QC Software
Batch Count	Up to 99
Production Strategies	Torque/Time, Torque & Angle, Torque + Angle CW/CCW Tightenigs
Quality Audit Strategy	Peak Torque, Torque plus Angle Automatic residual detection CW/CCW Tightenigs
Torque Accuracy	1% of torque reading +/- 1 digit
Angle Accuracy	+/- 1%
Battery	Li-Ion Battery
Power Autonomy	up to 10 hours for stand alone, 8 hours for wireless
USB Communication	Bi-directional communication to Delta QC Software
Results	1000 + 10 curves with Delta Licensed QC
RGB Display	Red Green or Blue backlight
Buzzer	Extension Torque and Angle bending correction
Multi-units	N•m, N•cm, Kg•cm, Kg•m, Oz•in, Lbf•in, Lbft
Languages	French, English, Spanish, Italian, Deutsch, Portuguese
Software	Free Delta QC software to define Pset and downloads results

>> IDEAL FOR E-PULSE SETTING (or any pulse tools model)

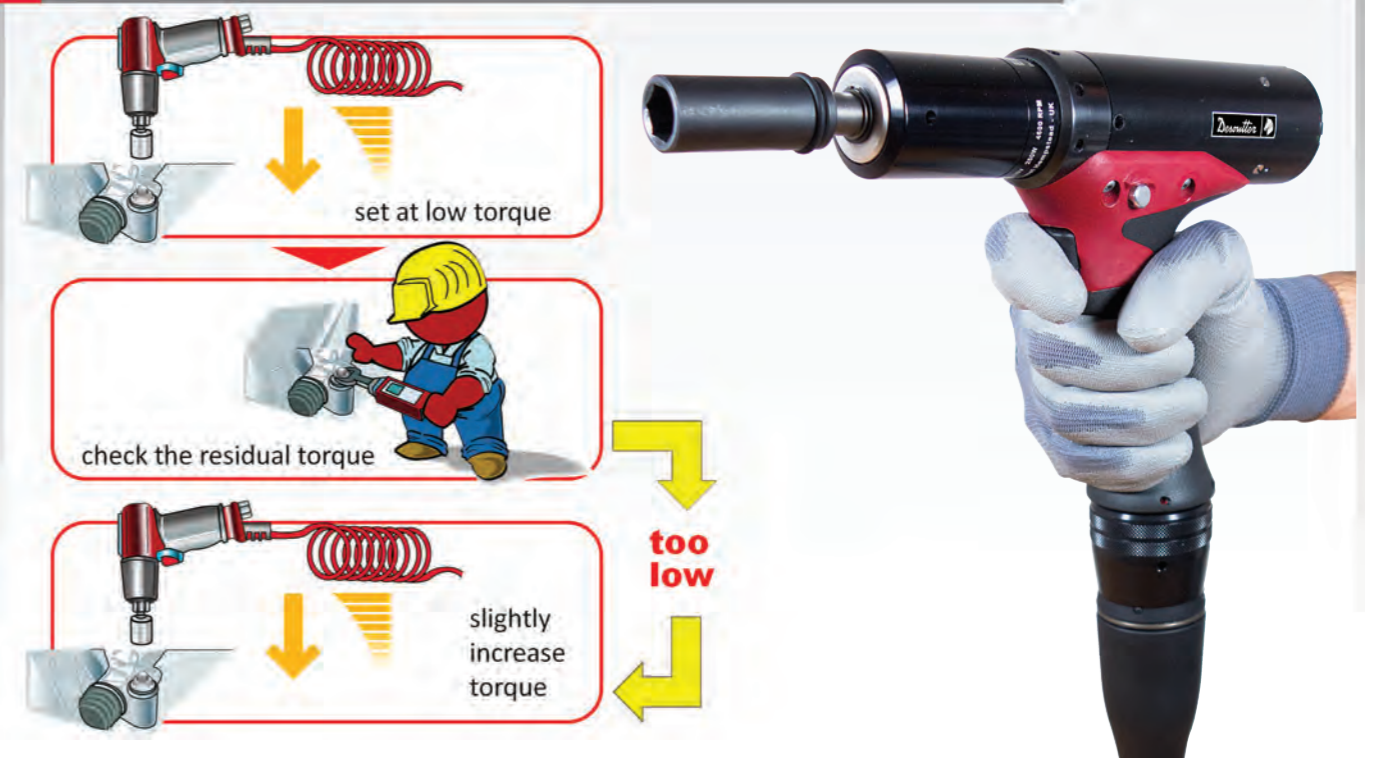



DELTA WRENCH

MODEL	PART NUMBER	RANGE		ANGLE	DRIVE		INCLUDED RATCHET		LENGTH		WEIGHT	
		Nm	ft lb		mm	in.	in	mm	in.	kg	lb	
Delta Wrench 30	615 165 771 0	3-30	2.21	✗	9x12	0.35x0.47	3/8	402	15.83	0.9	2.0	
Delta Wrench 150	615 165 772 0	15-150	11.06-110.6	✗	14x18	0.55x0.71	1/2	625	24.60	1.8	4.0	
Delta Wrench 400	615 165 773 0	40-400	29.50-295.0	✗	14x18	0.55x0.71	3/4	1026	40.40	2.8	6.2	
Delta Wrench 800	615 165 774 0	80-800	59.00-590.0	✗	Ø28	Ø1.1	1	1309	51.54	4.7	10.4	
Delta Wrench 30-A	615 165 775 0	3-30	2.21	✓	9x12	0.35x0.47	3/8	402	15.83	0.9	2.0	
Delta Wrench 150-A	615 165 776 0	15-150	11.06-110.6	✓	14x18	0.55x0.71	1/2	625	24.60	1.8	4.0	
Delta Wrench 150-A Short	615 165 767 0	15-150	11.06-110.6	✓	14x18	0.55x0.71	1/2	418	16.46	1.0	2.2	
Delta Wrench 400-A	615 165 777 0	40-400	29.50-295.0	✓	14x18	0.55x0.71	3/4	1026	40.40	2.8	6.2	
Delta Wrench 800-A	615 165 778 0	80-800	59.00-590.0	✓	Ø 28	Ø 1.1	1	1309	51.54	4.7	10.4	



■ Battery and battery charge

MODEL	PART NUMBER	HEIGHT		LENGTH		WIDTH		WEIGHT	
		mm	in	mm	in	mm	in	gr	lb
Delta Wrench Battery	615 936 150 0	-	-	110	4.33	Ø 22	Ø 8,86	80	0.18
Delta Wrench Battery Charger	615 936 151 0	60	2.36	140	5.51	80	3.15	240	0.53

All models are supplied with plastic box including reverseable ratchet with TAG and Delta QC Free Version CD-Rom

DeltaQC Software	FREE	LICENSED	ADVANCED
PSet programming	✓	✓	✓
Result viewer	✓	✓	✓
Result excel export	✓	✓	✓
Curve viewer		✓	✓
Result Database			✓

MODEL	PART NUMBER
DeltaQC Licensed 1 user	615 927 651 0
DeltaQC Licensed 5 users	615 927 652 0
DeltaQC Advanced 1 user	615 927 653 0
DeltaQC Advanced 5 users	615 927 654 0

Delta Wrench WLAN

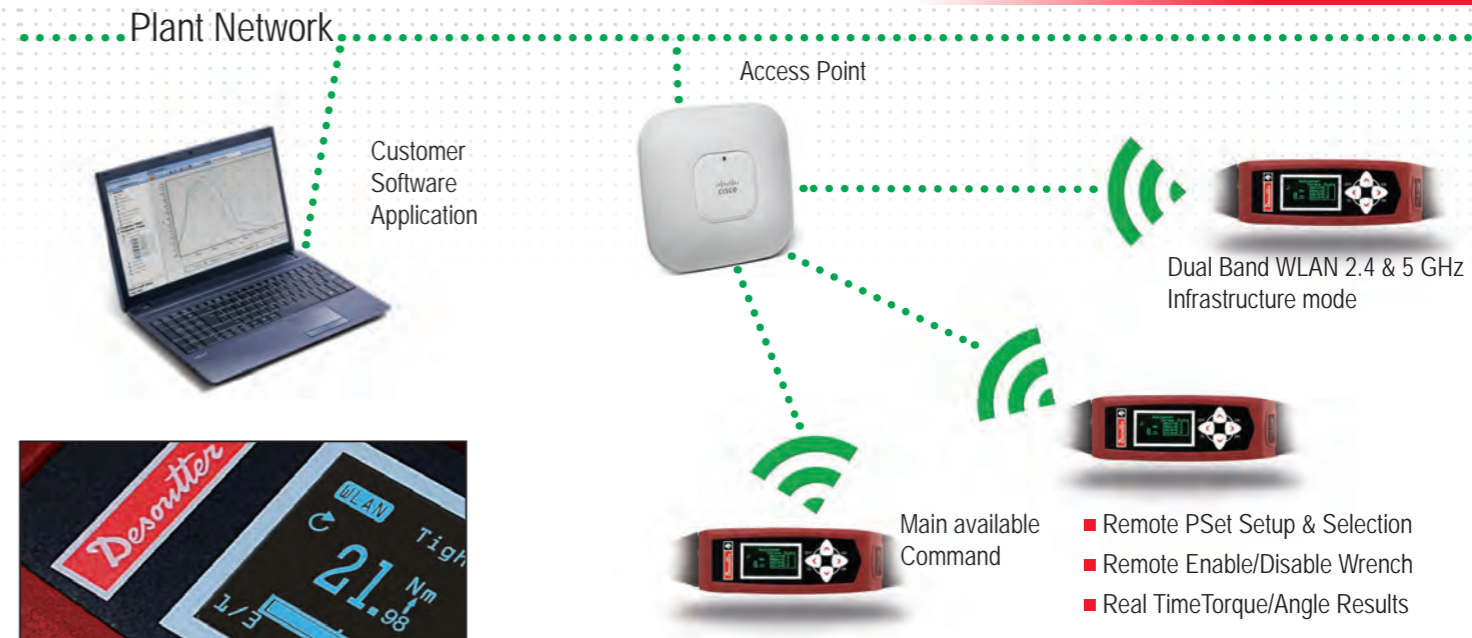

Thanks to simple bidirectional communication protocol, DeltaWrench Wlan (TCP Client), can be easily interfaced to custom applications (TCP Server), by developing a communication bridge software.

>> BENEFITS

- Real Time communication
- Protocol (ASCII format) fully available for easy custom integration
- Dual Band Wlan Module fully configurable by DeltaQC Software

MODEL	PART NUMBER	RANGE		ANGLE	DRIVE		INCLUDED RATCHET		LENGTH		WEIGHT	
		Nm	ft lb		mm	in.	in	mm	in.	kg	lb	
Delta Wrench 30 Wlan	615 165 781 0	3-30	2.21	✗	9x12	0.35x0.47	3/8	402	15.83	0.9	2.0	
Delta Wrench 150 Wlan	615 165 782 0	15-150	11.06-110.6	✗	14x18	0.55x0.71	1/2	625	24.60	1.8	4.0	
Delta Wrench 400 Wlan	615 165 783 0	40-400	29.50-295.0	✗	14x18	0.55x0.71	3/4	1026	40.40	2.8	6.2	
Delta Wrench 800 Wlan	615 165 784 0	80-800	59.00-590.0	✗	Ø28	Ø1.1	1	1309	51.54	4.7	10.4	
Delta Wrench 30-A Wlan	615 165 785 0	3-30	2.21	✓	9x12	0.35x0.47	3/8	402	15.83	0.9	2.0	
Delta Wrench 150-A Wlan	615 165 786 0	15-150	11.06-110.6	✓	14x18	0.55x0.71	1/2	625	24.60	1.8	4.0	
Delta Wrench 150-A Wlan Short	615 165 789 0	15-150	11.06-110.6	✓	14x18	0.55x0.71	1/2	418	16.46	1.0	2.2	
Delta Wrench 400-A Wlan	615 165 787 0	40-400	29.50-295.0	✓	14x18	0.55x0.71	3/4	1026	40.40	2.8	6.2	
Delta Wrench 800-A Wlan	615 165 788 0	80-800	59.00-590.0	✓	Ø28	Ø 1.1	1	1309	51.54	4.7	10.4	

MODEL	PART NUMBER
Access point Wifi 802.11N - US	615 811 417 5
Access point Wifi 802.11N - Europe	615 811 419 5



MODEL	PART NUMBER
Access Point Wifi7 802.11N - C	615 811 4205
Access Point Wifi7 802.11N - N	615 811 650 5
Access Point Power Cord UK	615 917 202 0

E-LIT BOX

>> FOCUS

1. Wireless communication
2. Fast to connect
3. Safe report
4. Visual feedback



Standard E-LIT Box Communication

>> CHARACTERISTICS

1. Wireless communication

- Low consumption
- Fast connection
- Long range communication
- Industrial wireless communication system (with 802-15-4 Technology)

2. Fast to connect

- Automatic free channel search
- Easy pairing process

3. Safe report

- Memorize up to 25 OK/NOK reports if lost communication
- Possibility to lock if memory full

4. Visual feedback

- Feedback directly on Wrench display
- Wireless communication
- Tightening OK / NOK



Delta Wrench ZigBee



8 available outputs including:

- ✓ OK
- ✓ NOK
- ✓ Tool ready
- ✓ Tool disable
- ✓ Batch complete

4 available inputs including:

- ✓ Lock tool
- ✓ Unlock tool
- ✓ Unlock tool and reset

EASY Pairing Process



No PC needed to pair E-LIT Box and Delta Wrench, just fast selection from wrench display

MODEL	PART NUMBER	RANGE		ANGLE	DRIVE		INCLUDED RATCHET LENGTH			WEIGHT	
		Nm	ft lb		mm	in.	in	mm	in.	kg	lb
Delta Wrench 30 ZigBee	615 165 800 0	3-30	2.21	✗	9x12	0.35x0.47	3/8	402	15.83	0.9	2.0
Delta Wrench 150 Zigbee	615 165 801 0	15-150	11.06-110.6	✗	14x18	0.55x0.71	1/2	625	24.60	1.8	4.0
Delta Wrench 400 ZigBee	615 165 802 0	40-400	29.50-295.0	✗	14x18	0.55x0.71	3/4	1026	40.40	2.8	6.2
Delta Wrench 800 ZigBee	615 165 803 0	80-800	59.00-590.0	✗	Ø28	Ø1.1	1	1309	51.54	4.7	10.4
Delta Wrench 30-A Zigbee	615 165 805 0	3-30	2.21	✓	9x12	0.35x0.47	3/8	402	15.83	0.9	2.0
Delta Wrench 150-A Zigbee	615 165 806 0	15-150	11.06-110.6	✓	14x18	0.55x0.71	1/2	625	24.60	1.8	4.0
Delta Wrench 150-A Zigbee Short	615 165 810 0	15-150	11.06-110.6	✓	14x18	0.55x0.71	1/2	418	16.46	1.0	2.2
Delta Wrench 400-A ZigBee	615 165 807 0	40-400	29.50-295.0	✓	14x18	0.55x0.71	3/4	1026	40.40	2.8	6.2
Delta Wrench 800-A ZigBee	615 165 808 0	80-800	59.00-590.0	✓	Ø28	Ø1.1	1	1309	51.54	4.7	10.4

ACCESSORIES MODEL	PART NUMBER	ELC TOOLS
E-LIT BOX-Z	615 936 086 0	✓

ACCESSORIES MODEL	PART NUMBER	ELC TOOLS
Power supply E-LIT BOX	615 927 053 0	✓

DELTA WRENCH ACCESSORIES

End Fittings with embedded RFID TAG*



OPEN END TAG - metric PART NO

Drive 9x12 Open End 7 mm. TAG	6159361520
Drive 9x12 Open End 8 mm. TAG	6159361530
Drive 9x12 Open End 9 mm. TAG	6159361540
Drive 9x12 Open End 10 mm. TAG	6159361550
Drive 9x12 Open End 11 mm. TAG	6159361560
Drive 9x12 Open End 12 mm. TAG	6159361570
Drive 9x12 Open End 13 mm. TAG	6159361580
Drive 9x12 Open End 14 mm. TAG	6159361590
Drive 9x12 Open End 15 mm. TAG	6159361600
Drive 9x12 Open End 16 mm. TAG	6159361610
Drive 9x12 Open End 17 mm. TAG	6159361620
Drive 9x12 Open End 18 mm. TAG	6159361630
Drive 9x12 Open End 19 mm. TAG	6159361640

RING BOX END TAG - metric PART NO

Drive 9x12 Ring Box End 7 mm. TAG	6159361650
Drive 9x12 Ring Box End 8 mm. TAG	6159361660
Drive 9x12 Ring Box End 10 mm. TAG	6159361670
Drive 9x12 Ring Box End 11 mm. TAG	6159361680
Drive 9x12 Ring Box End 12 mm. TAG	6159361690
Drive 9x12 Ring Box End 13 mm. TAG	6159361700
Drive 9x12 Ring Box End 14 mm. TAG	6159361710
Drive 9x12 Ring Box End 15 mm. TAG	6159361720
Drive 9x12 Ring Box End 16 mm. TAG	6159361730
Drive 9x12 Ring Box End 17 mm. TAG	6159361740
Drive 9x12 Ring Box End 18 mm. TAG	6159361750
Drive 9x12 Ring Box End 19 mm. TAG	6159361760
Drive 9x12 Ring Box End 21 mm. TAG	6159361770
Drive 9x12 Ring Box End 22 mm. TAG	6159361780

FLARED END TAG - metric PART NO

Drive 9x12 Flared End 10 mm. TAG	6159361790
Drive 9x12 Flared End 11 mm. TAG	6159361800
Drive 9x12 Flared End 12 mm. TAG	6159361810
Drive 9x12 Flared End 13 mm. TAG	6159361820
Drive 9x12 Flared End 14 mm. TAG	6159361830
Drive 9x12 Flared End 16 mm. TAG	6159361840
Drive 9x12 Flared End 17 mm. TAG	6159361850
Drive 9x12 Flared End 18 mm. TAG	6159361860
Drive 9x12 Flared End 19 mm. TAG	6159361870
Drive 9x12 Flared End 21 mm. TAG	6159361880
Drive 9x12 Flared End 22 mm. TAG	6159361890
Drive 9x12 Flared End 24 mm. TAG	6159361900

FLARED END TAG - inches PART NO

Drive 9x12 Flared End 3/8" TAG	6152210010
Drive 9x12 Flared End 7/16" TAG	6152210020
Drive 9x12 Flared End 1/2" TAG	6152210030
Drive 9x12 Flared End 9/16" TAG	6152210040
Drive 9x12 Flared End 5/8" TAG	6152210050
Drive 9x12 Flared End 11/16" TAG	6152210060
Drive 9x12 Flared End 3/4" TAG	6152210070

OPEN END TAG - inches PART NO

Drive 9x12 Open End 1/4" TAG	6159362290
Drive 9x12 Open End 5/16" TAG	6159362300
Drive 9x12 Open End 3/8" TAG	6159362310
Drive 9x12 Open End 7/16" TAG	6159362320
Drive 9x12 Open End 1/2" TAG	6159362330
Drive 9x12 Open End 9/16" TAG	6159362340
Drive 9x12 Open End 5/8" TAG	6159362350
Drive 9x12 Open End 11/16" TAG	6159362360
Drive 9x12 Open End 3/4" TAG	6159362370

RING BOX END TAG - inches PART NO

Drive 9x12 Ring Box End 1/4"	6159362380
Drive 9x12 Ring Box End 5/16"	6159362390
Drive 9x12 Ring Box End 3/8"	6159362400
Drive 9x12 Ring Box End 7/16"	6159362410
Drive 9x12 Ring Box End 1/2"	6159362420
Drive 9x12 Ring Box End 9/16"	6159362430
Drive 9x12 Ring Box End 5/8"	6159362440
Drive 9x12 Ring Box End 11/16"	6159362450
Drive 9x12 Ring Box End 3/4"	6159362460
Drive 9x12 Ring Box End 13/16"	6159362470
Drive 9x12 Ring Box End 7/8"	6159362480

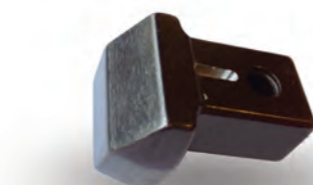

BLANK END TAG PART NO

Drive 9x12 Blank End TAG	6159362280
--------------------------	------------

BITS HOLDER TAG PART NO

Drive 9x12 Bits Holder 1/4" TAG	6152210280
Drive 9x12 Bits Holder 5/16" TAG	6152210290

REVERSIBLE RATCHET TAG PART NO

Drive 9x12 Reversible ratchet 1/4" TAG	6159361910
Drive 9x12 Reversible ratchet 3/8" TAG	6159361920
Drive 9x12 Reversible ratchet 1/2" TAG	6159361930



Delta Wrench Accessories

End Fittings with embedded RFID TAG*



OPEN END TAG - metric PART NO

Drive 14x18 Open End 13 mm. TAG	6159361940
Drive 14x18 Open End 14 mm. TAG	6159361950
Drive 14x18 Open End 15 mm. TAG	6159361960
Drive 14x18 Open End 16 mm. TAG	6159361970
Drive 14x18 Open End 17 mm. TAG	6159361980
Drive 14x18 Open End 18 mm. TAG	6159361990
Drive 14x18 Open End 19 mm. TAG	6159362000
Drive 14x18 Open End 21 mm. TAG	6159362010
Drive 14x18 Open End 22 mm. TAG	6159362020
Drive 14x18 Open End 24 mm. TAG	6159362030
Drive 14x18 Open End 27 mm. TAG	6159362040
Drive 14x18 Open End 30 mm. TAG	6159362050
Drive 14x18 Open End 32 mm. TAG	6159362060
Drive 14x18 Open End 34 mm. TAG	6159362070

RING BOX END TAG - metric PART NO

Drive 14x18 Ring Box End 13 mm. TAG	6159362080
Drive 14x18 Ring Box End 14 mm. TAG	6159362090
Drive 14x18 Ring Box End 15 mm. TAG	6159362100
Drive 14x18 Ring Box End 16 mm. TAG	6159362110
Drive 14x18 Ring Box End 17 mm. TAG	6159362120
Drive 14x18 Ring Box End 18 mm. TAG	6159362130
Drive 14x18 Ring Box End 19 mm. TAG	6159362140
Drive 14x18 Ring Box End 21 mm. TAG	6159362150
Drive 14x18 Ring Box End 22 mm. TAG	6159362160
Drive 14x18 Ring Box End 24 mm. TAG	6159362170
Drive 14x18 Ring Box End 27 mm. TAG	6159362180
Drive 14x18 Ring Box End 30 mm. TAG	6159362190
Drive 14x18 Ring Box End 32 mm. TAG	6159362200
Drive 14x18 Ring Box End 34 mm. TAG	6159362210
Drive 14x18 Ring Box End 36 mm. TAG	6159362220
Drive 14x18 Ring Box End 41 mm. TAG	6159362230

OPEN END TAG - inches PART NO

Drive 14x18 Open End 7/16" TAG	6152210080
Drive 14x18 Open End 1/2" TAG	6152210090
Drive 14x18 Open End 9/16" TAG	6152210100
Drive 14x18 Open End 5/8" TAG	6152210110
Drive 14x18 Open End 11/16" TAG	6152210120
Drive 14x18 Open End 3/4" TAG	6152210130
Drive 14x18 Open End 13/16" TAG	6152210140
Drive 14x18 Open End 7/8" TAG	6152210150
Drive 14x18 Open End 15/16" TAG	6152210160
Drive 14x18 Open End 1" TAG	6152210170
Drive 14x18 Open End 1,1/8" TAG	6152210180

RING BOX END TAG - inches PART NO

Drive 14x18 Box End 1/2" TAG	6152210190
Drive 14x18 Box End 9/16" TAG	6152210200
Drive 14x18 Box End 5/8" TAG	6152210210
Drive 14x18 Box End 11/16" TAG	6152210220
Drive 14x18 Box End 3/4" TAG	6152210230
Drive 14x18 Box End 13/16" TAG	6152210240
Drive 14x18 Box End 7/8" TAG	6152210250
Drive 14x18 Box End 15/16" TAG	6152210260
Drive 14x18 Box End 1" TAG	6152210270

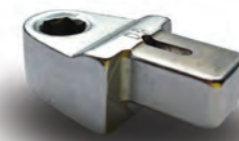

BITS HOLDER TAG PART NO

Drive 14x18 Bits Holder 5/16" TAG	6152210300
-----------------------------------	------------



BLANK END TAG PART NO

Drive 14x18 Blank End TAG	6159362260
---------------------------	------------



REVERSIBLE RATCHET TAG PART NO

Drive 14x18 Reversible ratchet 1/2" TAG	6159362240
Drive 14x18 Reversible ratchet 3/4" TAG	6159362250
Drive Ø 28 Reversible ratchet 1" TAG	6159362270

Delta Wrench Accessories

End Fittings without TAG*

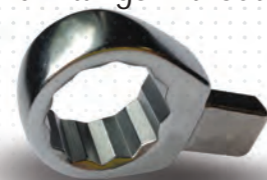

OPEN END - metric PART NO

Drive 9x12 Open End 7 mm.	615 397 055 0
Drive 9x12 Open End 8 mm.	615 397 056 0
Drive 9x12 Open End 9 mm.	615 397 057 0
Drive 9x12 Open End 10 mm.	615 397 058 0
Drive 9x12 Open End 11 mm.	615 397 059 0
Drive 9x12 Open End 12 mm.	615 397 060 0
Drive 9x12 Open End 13 mm.	615 397 061 0
Drive 9x12 Open End 14 mm.	615 397 062 0
Drive 9x12 Open End 15 mm.	615 397 063 0
Drive 9x12 Open End 16 mm.	615 397 064 0
Drive 9x12 Open End 17 mm.	615 397 065 0
Drive 9x12 Open End 18 mm.	615 397 066 0
Drive 9x12 Open End 19 mm.	615 397 067 0

OPEN END - inches PART NO

Drive 9x12 Open End 1/4"	615 397 069 0
Drive 9x12 Open End 5/16"	615 397 070 0
Drive 9x12 Open End 3/8"	615 397 071 0
Drive 9x12 Open End 7/16"	615 397 072 0
Drive 9x12 Open End 1/2"	615 397 073 0
Drive 9x12 Open End 9/16"	615 397 074 0
Drive 9x12 Open End 5/8"	615 397 075 0
Drive 9x12 Open End 11/16"	615 397 076 0
Drive 9x12 Open End 3/4"	615 397 077 0

RING BOX END - metric PART NO

Drive 9x12 Ring Box End 7 mm.	615 397 078 0
Drive 9x12 Ring Box End 8 mm.	615 397 079 0
Drive 9x12 Ring Box End 10 mm.	615 397 080 0
Drive 9x12 Ring Box End 11 mm.	615 397 081 0
Drive 9x12 Ring Box End 12 mm.	615 397 082 0
Drive 9x12 Ring Box End 13 mm.	615 397 083 0
Drive 9x12 Ring Box End 14 mm.	615 397 084 0
Drive 9x12 Ring Box End 15 mm.	615 397 085 0
Drive 9x12 Ring Box End 16 mm.	615 397 086 0
Drive 9x12 Ring Box End 17 mm.	615 397 087 0
Drive 9x12 Ring Box End 18 mm.	615 397 088 0
Drive 9x12 Ring Box End 19 mm.	615 397 089 0
Drive 9x12 Ring Box End 21 mm.	615 397 090 0
Drive 9x12 Ring Box End 22 mm.	615 397 091 0

RING BOX END - inches PART NO

Drive 9x12 Box End 1/4"	615 397 092 0
Drive 9x12 Box End 5/16"	615 397 093 0
Drive 9x12 Box End 3/8"	615 397 094 0
Drive 9x12 Box End 7/16"	615 397 095 0
Drive 9x12 Box End 1/2"	615 397 096 0
Drive 9x12 Box End 9/16"	615 397 097 0
Drive 9x12 Box End 5/8"	615 397 098 0
Drive 9x12 Box End 11/16"	615 397 099 0
Drive 9x12 Box End 3/4"	615 397 100 0
Drive 9x12 Box End 13/16"	615 397 101 0
Drive 9x12 Box End 7/8"	615 397 102 0

FLARED END - metric PART NO

Drive 9x12 Flared End 10 mm.	615 397 103 0
Drive 9x12 Flared End 11 mm.	615 397 104 0
Drive 9x12 Flared End 12 mm.	615 397 105 0
Drive 9x12 Flared End 13 mm.	615 397 106 0
Drive 9x12 Flared End 14 mm.	615 397 107 0
Drive 9x12 Flared End 16 mm.	615 397 108 0
Drive 9x12 Flared End 17 mm.	615 397 109 0
Drive 9x12 Flared End 18 mm.	615 397 110 0
Drive 9x12 Flared End 19 mm.	615 397 111 0
Drive 9x12 Flared End 21 mm.	615 397 112 0
Drive 9x12 Flared End 22 mm.	615 397 113 0
Drive 9x12 Flared End 24 mm.	615 397 114 0

FLARED END - inches PART NO

Drive 9x12 Flared End 3/8"	615 397 115 0
Drive 9x12 Flared End 7/16"	615 397 116 0
Drive 9x12 Flared End 1/2"	615 397 117 0
Drive 9x12 Flared End 9/16"	615 397 118 0
Drive 9x12 Flared End 5/8"	615 397 119 0
Drive 9x12 Flared End 11/16"	615 397 120 0
Drive 9x12 Flared End 3/4"	615 397 121 0

FIXED SQUARE DRIVE PART NO

Drive 9x12 Fixed Square Drive 1/4"	615 397 122 0
Drive 9x12 Fixed Square Drive 3/8"	615 397 123 0
Drive 9x12 Fixed Square Drive 1/2"	615 397 124 0

BLANK END PART NO

Drive 9x12 Blank End	615 397 130 0
----------------------	---------------

Delta Wrench Accessories

End Fittings without TAG*

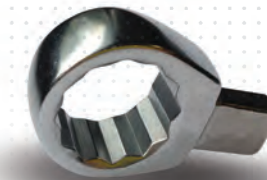

OPEN END - metric PART NO

Drive 14x18 Open End 13 mm.	615 397 131 0
Drive 14x18 Open End 14 mm.	615 397 132 0
Drive 14x18 Open End 15 mm.	615 397 133 0
Drive 14x18 Open End 16 mm.	615 397 134 0
Drive 14x18 Open End 17 mm.	615 397 135 0
Drive 14x18 Open End 18 mm.	615 397 136 0
Drive 14x18 Open End 19 mm.	615 397 137 0
Drive 14x18 Open End 21 mm.	615 397 138 0
Drive 14x18 Open End 22 mm.	615 397 139 0
Drive 14x18 Open End 24 mm.	615 397 140 0
Drive 14x18 Open End 27 mm.	615 397 141 0
Drive 14x18 Open End 30 mm.	615 397 142 0
Drive 14x18 Open End 32 mm.	615 397 143 0
Drive 14x18 Open End 34 mm.	615 397 144 0

OPEN END - inches PART NO

Drive 14x18 Open End 7/16"	615 397 145 0
Drive 14x18 Open End 1/2"	615 397 146 0
Drive 14x18 Open End 9/16"	615 397 147 0
Drive 14x18 Open End 5/8"	615 397 148 0
Drive 14x18 Open End 11/16"	615 397 149 0
Drive 14x18 Open End 3/4"	615 397 150 0
Drive 14x18 Open End 13/16"	615 397 151 0
Drive 14x18 Open End 7/8"	615 397 152 0
Drive 14x18 Open End 15/16"	615 397 153 0
Drive 14x18 Open End 1"	615 397 154 0
Drive 14x18 Open End 1,1/8"	615 397 172 0

RING BOX END - metric PART NO

Drive 14x18 Ring Box End 13 mm.	615 397 173 0
Drive 14x18 Ring Box End 14 mm.	615 397 174 0
Drive 14x18 Ring Box End 15 mm.	615 397 175 0
Drive 14x18 Ring Box End 16 mm.	615 397 176 0
Drive 14x18 Ring Box End 17 mm.	615 397 177 0
Drive 14x18 Ring Box End 18 mm.	615 397 178 0
Drive 14x18 Ring Box End 19 mm.	615 397 179 0
Drive 14x18 Ring Box End 21 mm.	615 397 180 0
Drive 14x18 Ring Box End 22 mm.	615 397 181 0
Drive 14x18 Ring Box End 24 mm.	615 397 182 0
Drive 14x18 Ring Box End 27 mm.	615 397 183 0
Drive 14x18 Ring Box End 30 mm.	615 397 184 0
Drive 14x18 Ring Box End 32 mm.	615 397 185 0
Drive 14x18 Ring Box End 34 mm.	615 397 186 0
Drive 14x18 Ring Box End 36 mm.	615 397 187 0
Drive 14x18 Ring Box End 41 mm.	615 397 188 0

RING BOX END - inches PART NO

Drive 14x18 Box End 1/2"	615 397 189 0
Drive 14x18 Box End 9/16"	615 397 190 0
Drive 14x18 Box End 5/8"	615 397 191 0
Drive 14x18 Box End 11/16"	615 397 192 0
Drive 14x18 Box End 3/4"	615 397 193 0
Drive 14x18 Box End 13/16"	615 397 194 0
Drive 14x18 Box End 7/8"	615 397 195 0
Drive 14x18 Box End 15/16"	615 397 196 0
Drive 14x18 Box End 1"	615 397 197 0



FIXED SQUARE DRIVE PART NO

Drive 14x18 Fixed Square Drive 1/2"	615 397 198 0
Drive 14x18 Fixed Square Drive 3/4"	615 397 199 0



FIXED SQUARE DRIVE PART NO

Drive 9x12 Fixed Square Drive 1/4"	615 397 122 0
Drive 9x12 Fixed Square Drive 3/8"	615 397 123 0
Drive 9x12 Fixed Square Drive 1/2"	615 397 124 0

BLANK END PART NO

Drive 9x12 Blank End	615 397 130 0
----------------------	---------------



BITS HOLDER PART NO

Drive 14x18 Bits Holder 5/16"	615 397 202 0
-------------------------------	---------------

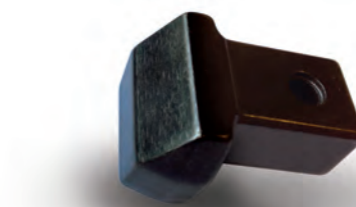

BLANK END PART NO

Drive 14x18 Blank End	615 397 203 0
-----------------------	---------------



REVERSIBLE RATCHET PART NO

Drive 14x18 Reversible ratchet 1/2"	615 397 200 0
Drive 14x18 Reversible ratchet 3/4"	615 397 201 0
Drive Ø 28 Reversible ratchet 1"	615 397 204 0



REVERSIBLE RATCHET PART NO

Drive 9x12 Reversible ratchet 1/4"	615 397 125 0
Drive 9x12 Reversible ratchet 3/8"	615 397 126 0
Drive 9x12 Reversible ratchet 1/2"	615 397 127 0



BITS HOLDER PART NO

Drive 9x12 Bits Holder 1/4"	615 397 128 0
Drive 9x12 Bits Holder 5/16"	615 397 129 0

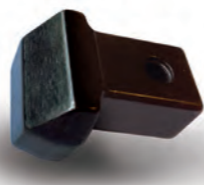

BLANK END PART NO

Drive 9x12 Blank End	615 397 130 0
----------------------	---------------

LOW TORQUE ANALYZER



■ Embedded Transducer & Battery



>> TECHNICAL SPECIFICATION

PART NO	DESCRIPTION
Torque Transducer	Embedded
Torque Accuracy	1% of readings
Tools Testing	Torque Wrench, Nutrunner or Pulse Tools
Statistic	Min. Max, Average, Standard Deviation
Results Storage	1000 + 10 curves with DeltaQC Licenced
Multi-units	N•m, Kg•m, Kg•cm, Oz•in, Lb•in, Lb•ft, N•cm
Display	Red, Green, Blue backlight
Power Supply	Embedded Battery External power supply
Battery Autonomy	Up to 12 hours
Languages	French, English, Spanish, Italian, Deutsch, Portuguese
Software	Free Delta QC Software to export by USB result

Alpha Low Torque Analyzer

>> MAIN FEATURES

- Alpha D Series is designed to monitor and collect torque check results from screwdrivers, torque wrenches or click wrenches.
- Ideal to tune the tools thanks to real time statistics on color display and high capacity torque results storage.
- Traceability with included software result acquisition with time stamp, including PDF or XLS reports.
- Three models with embedded transducer to cover torque range from 0,1 to 16 Nm. All models are provided with two included joint simulators to test nutrunner according to different joint stiffness condition.

MODEL	PART NUMBER
DJS for Alpha_D1 Soft	615 936 120 0
DJS for Alpha_D1 Hard	615 936 121 0
DJS for Alpha_D5 Soft	615 936 122 0
DJS for Alpha_D5 Hard	615 936 123 0
DJS for Alpha_D16 Soft	615 936 124 0
DJS for Alpha_D16 Hard	615 936 125 0
Universal Power Supplier	615 936 143 0

MODEL	PART NUMBER	P. CHARGER volts	TORQUE RANGE		DEPTH		WIDTH		HEIGHT		WEIGHT	
			Nm	in. - lb	mm	in.	mm	in.	mm	in.	kg	lb
Alpha D1	615 935 140 0	110/240V	0.1 - 1	0.88 - 8.85	106	4.17	180	7.09	70	2.76	0.95	2.1
Alpha D5	615 935 141 0	110/240V	0.5 - 5	4.42 - 44.25	106	4.17	180	7.09	70	2.76	0.95	2.1
Alpha D16	615 935 142 0	110/240V	1.6 - 16	14.1 - 141.6	106	4.17	180	7.09	70	2.76	0.95	2.1

All models are supplied with external power supply, suitable hard and soft joint simulators and Delta QC Software CD-ROM



■ Backlight RGB color display with acoustic buzzer

■ Hard & Soft Joint Simulator

DIGITAL ROTARY TRANSDUCER & ACCESSORIES

TORQUE ROTARY TRANSDUCER:

The Rotary Torque Transducer DRT4 is designed to measure the torque output of any non-impact assembly tool. The transducer is suitable for use with impulse type assembly tools brushes with minimal maintenance requirements.



>> BENEFITS

- Automatic recognition thanks to internal memory chip storing main data values eliminating any setting mistakes and time losses.
- High reliability due to immunity from external noise thanks to digital communication.
- Communication to data analyzer not sensitive to the cable length.
- Long life durability thanks to industrial design from transducer to housing.

>> FEATURES

- Torque range from 0,2 to 5000 Nm (0.15 to 3685 ft.lb).
- Strain gauges transducer: - sensitivity 2mV/V - accuracy +/-0.35% of torque reading.
- Built-in smart chip memory with calibration features: - type of transducer - sensitivity nominal load - serial number.

MODEL	PART NUMBER	TORQUE RANGE		OUTPUT
		Nm	ft. lb	
DRT4				
DRT 4 H 2	615 165 209 0	0.2 - 2	0.15 - 1.5	Hex ¼"
DRT 4 H 5	615 165 210 0	0.5 - 5	0.37 - 3.7	Hex ¼"
DRT 4 H 20	615 165 211 0	2 - 20	1.47 - 14.7	Hex ¼"
DRT 4 Sq 20	615 165 212 0	2 - 20	1.47 - 14.7	Sq ¼"
DRT 4 Sq 25	615 165 213 0	2.5 - 25	1.84 - 18.4	Sq ⅜"
DRT 4 Sq 75	615 165 214 0	7.5 - 75	5.53 - 55.3	Sq ⅜"
DRT 4 Sq 180	615 165 215 0	18 - 180	13.2 - 132	Sq ½"
DRT 4 Sq 500	615 165 216 0	50 - 500	36.8 - 368	Sq ¾"
DRT 4 Sq 1400	615 165 217 0	140 - 1400	103.2 - 1032	Sq 1"
DRT 4 Sq 3000	615 165 536 0	300 - 3000	221.1 - 2211	Sq 1-½"
DRT 4 Sq 5000	615 165 540 0	500 - 5000	368.5 - 3685	Sq 1-½"

DRT

A version DRT5 is available with an angle measurement encoder which allows with a DELTA 6D or DELTA 7D, the measurement of the angle of rotation in addition to torque.



MODEL	PART NUMBER	TORQUE RANGE		OUTPUT
		Nm	ft. lb	
DRT5				
DRT 5 H 2	615 165 218 0	0.2 - 2	0.15 - 1.5	Hex ¼"
DRT 5 H 5	615 165 219 0	0.5 - 5	0.37 - 3.7	Hex ¼"
DRT 5 H 20	615 165 220 0	2 - 20	1.47 - 14.7	Hex ¼"
DRT 5 Sq 20	615 165 221 0	2 - 20	1.47 - 14.7	Sq ¼"
DRT 5 Sq 25	615 165 222 0	2.5 - 25	1.84 - 18.4	Sq ⅜"
DRT 5 Sq 75	615 165 223 0	7.5 - 75	5.53 - 55.3	Sq ⅜"
DRT 5 Sq 180	615 165 224 0	18 - 180	13.2 - 132	Sq ½"
DRT 5 Sq 500	615 165 225 0	50 - 500	36.8 - 368	Sq ¾"
DRT 5 Sq 1400	615 165 226 0	140 - 1400	103.2 - 1032	Sq 1"
DRT 5 Sq 5000	615 165 780 0	500 - 5000	368.5 - 3685	Sq 1-½"

>> FEATURES

- Torque range from 0.2 to 1400 Nm (0.15 to 1032 ft.lb).
- Angle counting system 0.35° resolution.
- Strain gauges transducer: - sensitivity 2mV/V - accuracy +/-0.35% of torque reading.
- Built-in smart chip memory with calibration features: - type of transducer - sensitivity nominal load - serial number.

Same size for torque or torque & angle transducer

OUTPUT	A		B		C		E		H		F		G	
	mm	in.	mm	in.	mm	in.	mm	in.	mm	in.	mm	in.	mm	in.
Hex ¼"	116	4.56	31	1.22	71.9	2.83	56	2.2	15.5	0.61	39	1.53	25.5	1
Sq ¼"	71.5	2.81	31	1.22	71.9	2.83	56	2.2	15.5	0.61	6	0.24		
Sq ⅜"	77	3.03	31	1.22	71.9	2.83	56	2.2	15.5	0.61	8	0.31		
Sq ½"	87	3.42	42	1.65	82.9	3.26	58	2.28	21	0.83	12	0.47		
Sq ¾"	106	4.17	52	2.05	92.9	3.66	66	2.60	26	1.02	21	0.83		
Sq 1"	125	4.92	65	2.56	104.9	4.13	73	2.87	32.5	1.28	29	1.14		
Sq 1-½"	165	6.5	106	4.17	148.5	5.85	88	3.46	53	2.09	35.2	1.39		

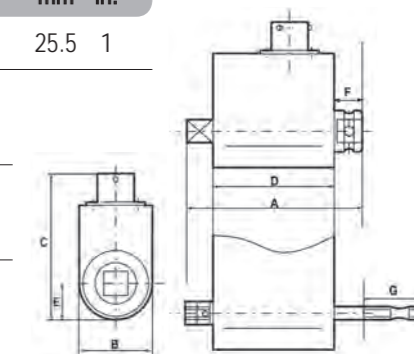

TRANSDUCER CABLES	DATA COLLECTOR	FOR TRANSDUCER	LENGTH	PART NUMBER
Description	type			
Digital 10 pins	All types of Delta	All digital transducers	2m (78.7") long	615 917 430 0
Digital 10 pins	All types of Delta	All digital transducers	2m (78.7") long, spiral	615 917 432 0
Digital 10 pins	All types of Delta	All digital transducers	5m (196.8") long	615 917 433 0

STATIC TRANSDUCER

Designed for testing wrenches, click wrenches or for tightening tools where rotary action is not desired during measurement. In the case of a Shut-Off tool test a joint simulator as an accessory is required.



MODEL	PART NUMBER	TORQUE RANGE		SQUARE DRIVE	DIMENSIONS				WEIGHT	
		Nm	ft.lb		A	B	kg	lb		
DST 0,5 Nm - 13	615 165 537 0	0.05-0.5	0.04-0.4	1/2	81	3.19	91	3.58	2.2	5.1
DST 2 Nm - 13	615 165 532 0	0.2-2	0.15-1.5	1/2	81	3.19	91	3.58	2.2	5.1
DST 5 Nm - 13	615 165 533 0	0.5-5	0.37-3.7	1/2	81	3.19	91	3.58	2.3	5.1
DST 10 Nm - 20	615 165 534 0	1-10	0.74-7.4	3/4	86	3.38	93	3.66	3.1	6.8
DST 30 Nm - 20	615 165 535 0	3-30	2.21-22	3/4	89	3.50	96	3.78	3.4	7.5
DST 80 Nm - 25	615 165 538 0	8-80	5.89-59	1	108	4.25	116	4.57	5.8	12.8
DST 200 Nm - 25	615 165 539 0	20-200	14.7-147	1	108	4.25	116	4.57	5.8	12.8
DST 500 Nm - 32	615 165 541 0	50-500	36.8-368	1-1/4	133	5.24	144	5.67	11.8	26.0
DST 1000 Nm - 32	615 165 542 0	100-1000	73.7-737	1-1/4	133	5.24	144	5.67	11.9	26.2
DST 2000 Nm - 32	615 165 543 0	200-2000	147.4-1474	1-1/2	133	5.24	144	5.67	12.0	26.4



Joint Simulator

A wide range of mechanical joint simulators are available to reproduce the joint behavior; installing the joint simulator on a transducer allows you to test a tool in the same real working conditions.

Each joint simulator reproduces a specific stiffness as described in its torque/angle characteristics. For each capacity, there are two versions: one reproducing a softer joint and one reproducing a harder joint.



MODEL	PART NUMBER	TORQUE MAX		COLOUR		SQUARE DRIVE		WEIGHT	
		Nm	ft.lb	INSIDE	OUTSIDE	in	out	kg	lb
DJS for DST 2 Soft	615 165 529 0	2	1.5	Yellow	Yellow	1/2	Hex1/4	0.12	0.26
DJS for DST 2 Hard	615 165 530 0	2	1.5	Yellow	Black	1/2	Hex 1/4	0.12	0.26
DJS for DST 5 Soft	615 165 531 0	5	3.7	Green	Yellow	1/2	Hex 1/4	0.12	0.26
DJS for DST 5 Hard	615 165 571 0	5	3.7	Green	Black	1/2	Hex 1/4	0.12	0.26
DJS for DST 10 Soft	615 165 574 0	10	7.4	Red	Yellow	3/4	3/8	0.64	1.41
DJS for DST 10 Hard	615 165 575 0	10	7.4	Red	Black	3/4	3/8	0.64	1.41
DJS for DST 30 Soft	615 165 577 0	30	22	Blue	Yellow	3/4	3/8	0.65	1.43
DJS for DST 30 Hard	615 165 579 0	30	22	Blue	Black	3/4	3/8	0.65	1.43
DJS for DST 80 Soft	615 165 584 0	80	59	Purple	Yellow	1	1/2	2.50	5.51
DJS for DST 80 Hard	615 165 587 0	80	59	Purple	Black	1	1/2	2.50	5.51
DJS for DST 200 Soft	615 165 588 0	200	147	Grey	Yellow	1	1/2	2.60	5.73
DJS for DST 200 Hard	615 165 589 0	200	147	Grey	Black	1	1/2	2.60	5.73
DJS for DST 500 Soft	615 165 590 0	500	369	Black	Yellow	1-1/4	3/4	5.00	11.02
DJS for DST 500 Hard	615 165 591 0	500	369	Black	Black	1-1/4	3/4	5.00	11.02
DJS for DST 1000	615 165 572 0	1000	737			1-1/4	1	10.30	22.70
DJS for DST 2000	615 936 137 0	2000	1475			1-1/2	1	14.08	28.83

MODEL	PART NUMBER	MODEL	PART NUMBER	MODEL	PART NUMBER
3/4" M-1/4" F	615 397 205 0	1/2" M-3/8" F	615 936 111 0	HEX 1/4" M-1/4" F	615 936 118 0
3/4" M-3/8" F	615 397 206 0	1/2" F-3/8" F	615 936 112 0	HEX 1/4" M-3/8" F	615 936 119 0
1" M-1/2" F	615 397 207 0	1/2" M-1/2" F	615 936 113 0	1" F-3/4" F	615 936 126 0
1" 1/4 M-1/2" F	615 397 208 0	1" 1/4 M-3/4" F	615 936 114 0	3/4" F-1/2" F	615 936 130 0
1" 1/4 M-3/4" F	615 397 209 0	1/4" F-3/8" F	615 936 115 0	1" 1/2 F-1" 1/2 F	615 936 131 0
1/4" F-1/4" F	615 397 210 0	1" 1/4 M-1" F	615 936 116 0	1/2" F-1/2" F	615 165 573 0
3/8" F-3/8" F	615 397 211 0	1" F-1" F	615 936 117 0	3/4" F-3/4" F	615 165 576 0
1" M-3/4" F	615 936 110 0				



CALIBRATION BENCH

EMBEDDED TRANSDUCERS:

Assembly tools calibration process requires a flexible and versatile solution, high quality performance even in production lines. Desoutter Tools is proud to present the Delta Cart, an ergonomic and attractive solution to improve quality in assembly processes.

■ Delta Cart offers a wide torque range since it can be configured up to 4 static transducers to cover from 0.2 Nm to 1 000 Nm (0.15 to 738 ft.lb) in a very compact dimensions (510mm width), making the Delta Cart the ideal solution for tool testing in assembly production lines.



■ Embedded PC equipped with wide 12" color touch screen lets operators to start tool testing in a few seconds and few steps.



■ Delta Cart includes all adapters, reaction bars and suitable joint simulators. Optional ISO RIG for torque wrench to eliminate operator influence during calibration, reducing efforts for high torque range.

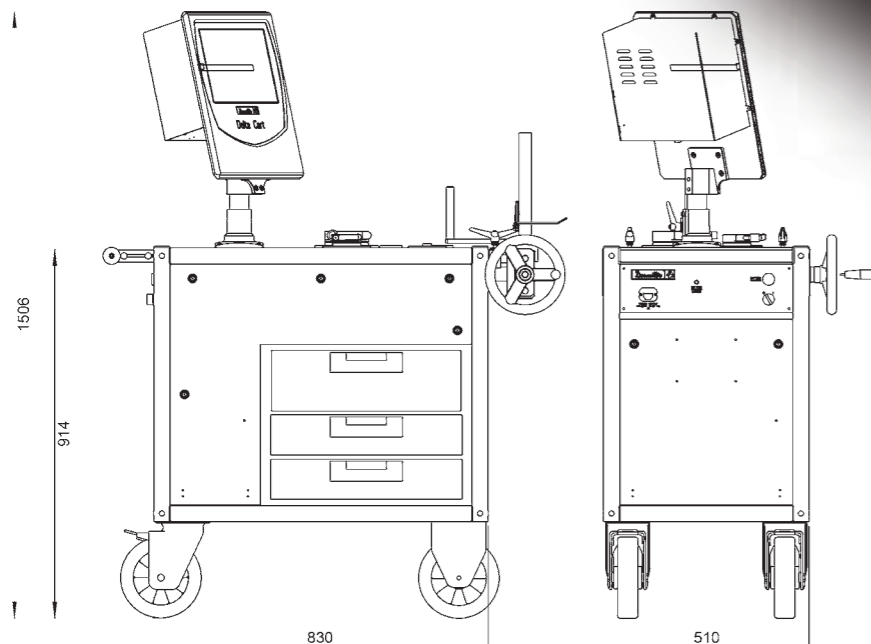

Delta Cart Tool Calibration



Electric and Pneumatic Nutrunner

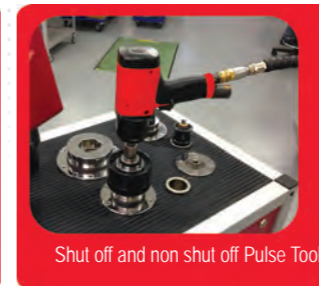

Shut off and non shut off Pulse Tool

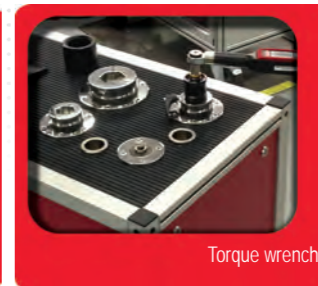

Torque wrench



Click wrench

The Delta Cart is able to follow your tools during the complete life span: by performing capacity test (Cm/Cmk) before tool is introduced into production, or monitoring tool performance during production assembly process by performing Statistic Process Control (SPC) test.

>> TECHNICAL FEATURES

- Configurable torque range from 1 Nm to 1000Nm
- Torque reaction bar and joint simulator included
- External DRT communication for in-line calibration
- Angle Strategy with external DRT5

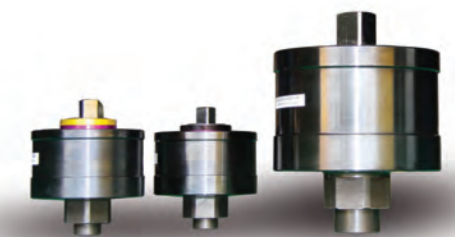

DELTA CART TOOL CALIBRATION

Embedded Software with local tool DB (SQL Server) containing all Tool of the line including:

■ Calibration STATUS 

■ Next Calibration



■ Cm / Cmk Reports

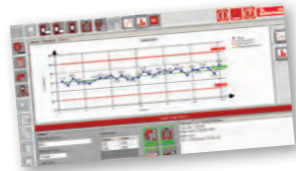

■ X/R Charts

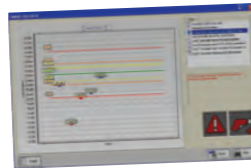

■ PST High accuracy static transducers with locking system specially designed for pulse tool calibration



■ ISO RIG System for torque wrench calibration

Delta Cart

CLIENT - SERVER Architecture

- Ideal for >1 cart management
- All Calibration data always synchronized with unique Server database
- Fast Ethernet communication

Delta QC ADVANCED DB (optional)



ROUTE 1
ROUTE 2

ROUTE 3
ROUTE N

ROUTER MANAGEMENT

- Send to Delta Cart just the Tool to be tested



>> SOFTWARE FEATURES

Torque Wrench, Electric or Pneumatic Nutrunner Test, Pulse Test	Local Test Database up to 30.000 Tests - Setting: Nominal Min Max Torque, unit of measure, Test ID, Test Description, Transducer number, Timeout setting
Cm/Cmk - ISO 3534	Cm/Cmk, min, max, average, sigma
Statistic Control - ISO 8258	X/R Charts for trend control
Print	Direct printing from Cart PC
Export	Certificate export PDF or XLS
Curve	Torque/Time or Torque/Angle with DRT5
Barcode	External USB
Configurable for each test	N•m - gf•cm - Kgf•cm - kgf•m - ozf•in - lbf•in - lbf•ft
Languages	English, French, Italian, German, Russian

DELTA QC SOFTWARE

The Delta QC software is the common software platform for all Delta QC measurement equipments. Included features are programming, results and trace viewer ensuring production data traceability. Statistic machine capability tool or SPC are also ensured thanks to local database available in the Advanced version, suitable to keep always updated the status of all tools in the line.

PART NUMBER	MODEL	PART NUMBER	MODEL
615 927 651 0	Delta QC Licensed 1 User	615 927 653 0	Delta QC Advanced 1 User
615 927 652 0	Delta QC Licensed 5 Users	615 927 654 0	Delta QC Advanced 5 Users



Advanced

Advanced version provides a local result database and offline programming. All results, traces and statistics are available for review, export and reporting in both on line and off line mode. All tool and PSet are always available in the local DB.

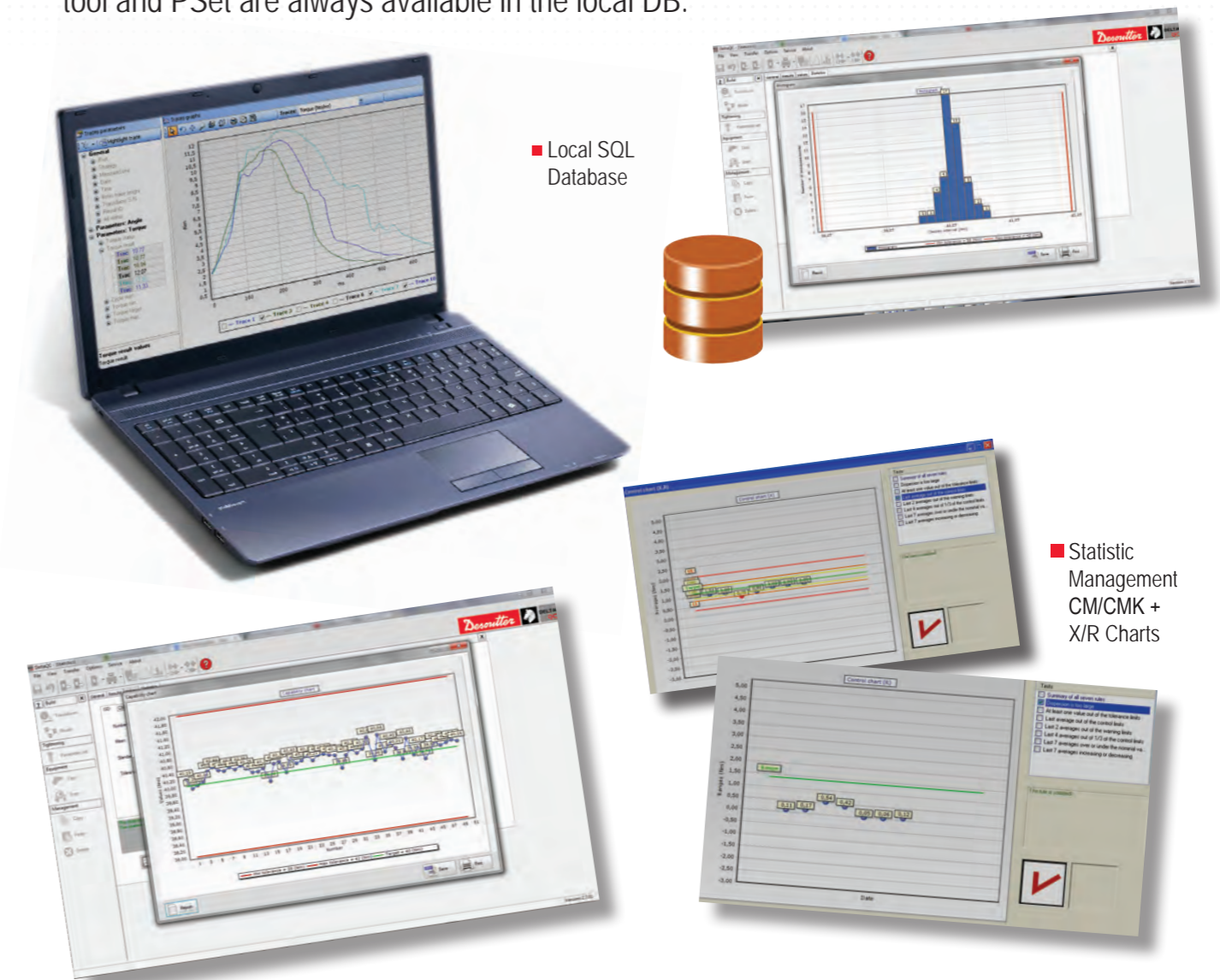

Local SQL Database

Statistic Management
 CM/CMK +
 X/R Charts

Embedded Tool DB (SQL Server) containing all Tool of the line including:

Calibration STATUS ● ● ●

Next Calibration



Cm / Cmk Reports

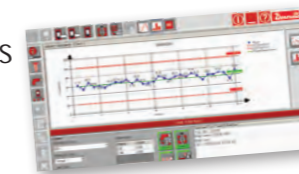

X/R Charts



DELTA QC SOFTWARE

Licensed

- Licenced version for online device programming and online result export



■ PSet, Tool programming



■ Result and Trace Viewer, Excel EXPORT and PRINTING

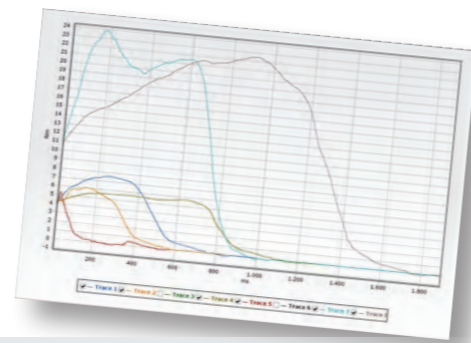

Free Version

Delta Wrench and Alpha D product range are supplied with the Delta QC software. Without any registration the Delta QC is able to program Delta Wrench Delta and Alpha, download results, export to excel and print.

>> MAIN FUNCTION >> Delta D

	FREE	LICENCED	ADVANCED
Pset programming	✓	✓	✓
Tool Definition	✓	✓	✓
Route Definition		✓	✓
Transducer Definition	✓	✓	✓
Pset Database		✓	✓
Tool Database		✓	✓
Route Database		✓	✓
Statistic (online only)		✓	✓
Result viewer	✓	✓	✓
Result excel export	✓	✓	✓
Curve viewer		✓	✓
Curve excel, JPEG export		✓	✓
Curve comparison		✓	✓
RESULT Database			✓
Curve Database			✓
Offline statistic			✓

>> MAIN FUNCTION >> Delta Wrench

	FREE	LICENCED	ADVANCED
Pset programming	✓	✓	✓
Result viewer	✓	✓	✓
Result excel export	✓	✓	✓
PSet DataBase		✓	✓
Curve viewer		✓	✓
Result Database			✓

>> MAIN FUNCTION >> Alpha D

	FREE	LICENCED	ADVANCED
Result viewer	✓	✓	✓
Result excel export	✓	✓	✓
Curve viewer		✓	✓

>> MAIN FUNCTION >> Delta Cart

	FREE	LICENCED	ADVANCED
Pset programming			✓
Pset Database			✓
Result viewer			✓
Result excel report			✓
Result Database			✓
Offline statistic			✓

Available Now At PneumaticToolsOnline.com
For Quotes or Questions Call Our Sales Engineers At 1-800-353-4676
ZAMPINI INDUSTRIAL

More Than Productivity



www.desouttertools.com

English - January 2015
© Copyright 2014 - Issue 1