



Form 16575318
Edition 1
April 2005

Electric Screwdrivers

EL 24V Series

Maintenance Information



Save These Instructions

IR Ingersoll-Rand®

WARNING

- Maintenance procedures have the potential for severe shock hazard and should be performed by qualified personnel.
- Always wear eye protection when operating or performing maintenance on this tool. Always turn off the electrical supply and disconnect the electrical cord before installing, removing or adjusting any accessory on this tool, or before performing any maintenance on this tool.

Disassembly

Disassembly of the Housing

1. To disassemble the Housing (1 or 44), begin by unscrewing the connection ring to remove the Power Cord (6 or 55).
2. Use a 29mm open end wrench to unscrew the coupling (56 or 6).

NOTICE

This is a left-hand thread.

3. Using a #1 phillips screwdriver, remove the Housing Screws (2 or 45).
4. Separate the Housing by lifting the half with the three screw holes. If necessary, use a small screwdriver to pry the Housing apart. Refer to Dwg. TPD1816.

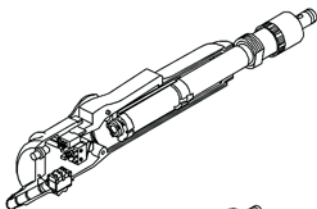

(Dwg. TPD1816)

5. Remove the Trigger (17 or 51), Trigger Spring (18 or 52) and the Trigger Pin (19 or 53).
6. Remove the Housing Bushing (7 or 54) from the back of the tool.

Disassembly of the Clutch Housing & Gear Case

1. Lift the Clutch Housing (53 or 8), Gear Case (37 or 22) and Motor Assembly from the Housing. While holding firmly, pull the Gear Case away.
2. Tap the end of the Gear Case on the work bench to remove the Motor Clamp Spacer (36 or 23) and the Gear Head Assembly (38 or 20).
3. Remove the Gear Head Planet Gears (39 or 21) from the Gear Head.
4. Remove the Push Rod (46 or 17) from the Gear Case. Fit the two notches at the rear end of the Gear Case Fixture part no. EL0410B-J37. Refer to Dwg. TPD1813.

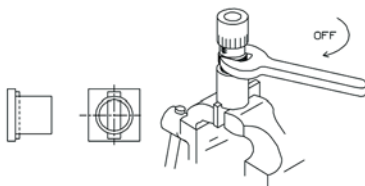

(Dwg. TPD1813)

5. Using a slotted screwdriver, remove the Front Bit Retainer Retaining Ring (60 or 3) from the Bit Holder Assembly (48 to 12).
6. Remove the Bit Retainer Sleeve (58 or 4) and Bit Retainer Sleeve Spring (59 or 5).
7. Remove the two Bit Retaining Balls (50) from the Bit Holder by tapping the Bit Holder on the work bench.

NOTICE

Model EL0109 has only one Bit Retaining Ball (11).

8. Unscrew and remove the Clutch Adjusting Ring (57 or 1) from the Clutch Housing. For Model EL0109, also remove the Bit Retainer Spring (2).
9. Remove the three Clutch Adjusting Pins (54 or 7) from the Clutch Housing and the Bit Retainer Sleeve Spring.
10. Remove the Bit Retainer Retaining Ring (55) using external snap ring pliers.
11. Using a 21mm open end wrench on the flats of the Clutch Housing Assembly, unscrew and remove the Clutch Housing.

NOTICE

This is a left-hand thread.

12. Remove the Clutch Spring Plate (52 or 9) and the Clutch Spring (51 or 10).
13. Lift the Bit Holder Assembly from the Gear Case.
For Model EL0109, remove the Cam Guide (13) and the two Cam Guide Balls (14) from the Bit Holder.
For Models EL1007 and EL0410, remove the two cam Guide Balls (49) and Cam Guide Sleeve (47) from the Bit Holder Assembly (48).
14. Remove the Gear Case from the Gear Case Fixture. Turn it over and push the Spindle Assembly (40 or 18) from the case.
15. Remove the Spindle Planet Gears (41 or 19) from the Spindle Assembly.
16. **For Model EL0109**, remove the Cam (16) and Cam Guide Sleeve Assembly (15) from the bearing.
For Model EL1007, remove the Cam Collar (45), the Cam (43), two Cam Pins (44) and the Thrust Washer (42).

Cleaning and Inspection of the Tool

1. Clean all mechanical parts you have disassembled in an approved safety solvent in a well-ventilated area. Inspect for damage or wear.
2. **For all Models**, inspect the Bit Holder Assembly. If the bearing does not rotate smoothly, replace the Bit Holder Assembly.
3. Inspect the Cam. If it is worn, replace it.
4. **For Model EL1007**, inspect the Cam Pins (44). If they are worn, replace them.
5. **For Model EL0109**, inspect the Cam Guide Sleeve. If the bearing of the Cam Guide Sleeve does not rotate smoothly, replace it.
6. Inspect all the Gear head Planet Gears. If the teeth are worn or damaged, replace them.
7. Inspect the Gear Case. If the inner gear teeth are worn or damaged, replace them.
8. Inspect the Spindle Assembly. If the bearing does not rotate smoothly, replace the Spindle Assembly.

Disassembly and Inspection of the motor

1. Remove the Motor Assembly, the Plunger (13 or 37) and the Plunger Spring (14 or 38) from the Housing.
2. Using a thin slotted screwdriver, release the tension on the Brush Spring (25 or 35) and remove the two Brush Assemblies (24 or (33) from the Rear End Plate (23 or 32).
3. Carefully pull the copper wires to remove the Brush Assemblies from the Rear End Plate.

NOTICE

Be careful not to damage the wires.

- If the Brush Assemblies need to be replaced, desolder the blue and red Motor wires and remove the Brush Screws (26 or 34).
- Using a thin blade screwdriver, remove the Motor Assembly Springs (34 or 31) by inserting the screwdriver between the Springs and Rear End Plate and prying upward.
 - Remove the Front End Plate (33 or 24) from the Field (32 or 25).
 - Remove the Rear End Plate and the Motor Plate (27 or 30) by inserting a slotted screwdriver into the space between the Rear End Plate and the Field and prying upward.
 - While pushing the Rear Armature Bearing (28 or 29), pull the Armature (31 or 26) from the Field.

NOTICE

Do not damage the commutator or windings on the Armature. Hold the Armature body, not the commutator, when removing.

- Remove the Push Rod (35 or 36) from the Armature.
- Inspect the Push Rod. If it is worn, replace it.
- Inspect the Rear Armature Bearing. If it does not rotate smoothly, replace it.
- Inspect the gear teeth on the Armature. If they are worn or damaged, replace the Armature.
- Inspect the front armature Bearing. If it does not rotate smoothly, replace the Armature.
- Inspect the commutator. If it is worn, replace the Armature.
- Clean the Armature. Field, Motor Plate and the End Plates using a piece of fine cloth. For excess contamination, spray with contact cleaner and brush if necessary.

Disassembly and Inspection of Electronics

- To remove the Trigger Switch (8 or 50), Reverse Switch (9 or 48) or Brake Switch (15 or 42), remove any screws and pull the Switch from the Housing. Desolder and remove the lead wires.
- To remove the Insulator (71 or 49), desolder the lead wires.

Assembly

Assembly of the Electronics

NOTICE

Before soldering any wire, slip a piece of heat shrinkable tubing over the wire.

- To assemble the Electronic Components, resolder all wires to the Insulator (71 or 49). Also resolder all wires to the Brake Switch (15 or 42) and the Trigger Switch (8 or 50).
- Reattach the Brake Switch to the Switch Plate (10 or 39) and screw the Plate into the Housing (1 or 44).
- Insert all electronic components into their proper locations. Refer to Dwg. TPD1817.

NOTICE

Be sure the notch in the Insulator fits with the tab in the Housing.

Assembly of the Motor

- Carefully insert the gear end of the Armature (31 or 26) into the notched side of the Field (32 or 25).

NOTICE

Be careful not to damage the commutator or windings.

- Install the Front End Plate (33 or 24) onto the Field.
- Place the Motor Plate (27 or 30) onto the Rear End Plate (23 or 32).

NOTICE

Be sure to install the Motor Plate correctly. The edge of the Motor Plate must be parallel to the step in the Rear End Plate.

- Push the Rear End Plate into the notches of the Field.
- Snap the motor Assembly Springs (34 or 31) into the notches of the End Plates.
- Insert the Brush Assembly (24 or 33) into the Rear End Plate. Be careful not to twist or damage the copper wire.

NOTICE

Make sure the Brush Assembly is positioned correctly. The connection point of the copper wire on the Brush Assembly should be closer to the rear end than the front end of the Motor Assembly.

- Insert the Brush Spring (25 or 35) into the Rear End Plate. Using a small screwdriver to tension the Spring, insert the end of the Brush Spring into the notch on the End Plate.
- Solder the blue and red Motor lead wires if the Brush Springs were replaced. Refer to Dwg. TPD1814.

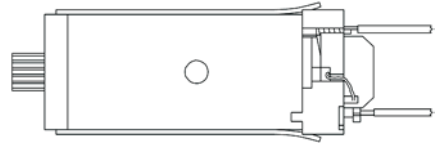

(Dwg. TPD1814)

- Apply grease to both ends of the Push rod (35 or 36) and insert it into the center hole of the Motor Assembly.

Assembly of the Gear Case and Clutch Housing

- Place the three Spindle Planet Gears (41 or 19) onto the Spindle Assembly (40 or 18).
- Place the three Gear Head Planet Gears (39 or 21) onto the Gear Head Assembly (38 or 20).
- Grease the gears.
- Place the Gear Head Assembly onto the Spindle Assembly.
- Grease both sides of the Thrust Washer (42) and place it on the Spindle bearing.
- Insert the Cam (43 or 16) into the Spindle Assembly.
- While rotating the Gear Case (37 or 22) and holding the Cam, insert all parts into the Gear Case.
- Grease the Gear Case side of the Motor Clamp Spacer (36 or 23) and insert the Motor Clamp Spacer into the Gear Case.
- For Model EL1007**, grease the notches on the Cam and place the two Cam Pins (44) into the notches.
- Grease the inside of the bit Holder Assembly (48 or 12).
- Insert the Cam Guide Sleeve (47 or 15) into the bit Holder.
- Grease the ball bearings under the spring support on the Bit Holder Assembly.
- Grease the holes on the bit Holder and insert the two Cam Guide Balls (49 or 14).
- For Model EL1007**, grease the inside of the Cam Collar (45) and place it onto the Bit Holder.
- For Model EL0109**, grease the bottom end of the Bit Holder Assembly and place the Cam Guide (13) onto the Bit Holder. Grease the holes in the Cam Guide and insert the two Cam Guide Balls.
- Fit the two notches at the rear of the Gear Case Assembly into the Gear Case Fixture part no. EL0410B-J37.
- Place the Bit Holder Assembly into the Gear Case.
- Place the Clutch Spring (51 or 10) and the Clutch Spring Plate (52 or 9) over the Bit holder.
- Place the Clutch Housing (53 or 8) partially into the Gear Case.

NOTICE

This is a left hand thread.

At the middle of the Clutch housing threads apply Loctite® Thread Locker 3 Bond 1406 to three of the threads. Screw the Clutch Housing all the way into the Gear Case.

- Using an open end torque wrench, tighten the Clutch Housing to 20 Nm torque.
- Install the Bit Retainer Retaining Ring (55 or 3) into the groove of the bit Holder. Place the side with the sharp edge first.
- Apply grease to the holes of the Bit Holder and insert the two Bit Retaining Balls (50 or 11) into the Bit Holder.

NOTICE

Model EL0109 has only one bit Retaining Ball.

23. Apply grease to one end of the each Clutch Adjusting Pin (54 or 7) and insert them into the Clutch Housing.
24. For Model EL0109, place the Clutch Adjusting Ring (1) and Bit Retainer Spring (2) onto the Clutch Housing.
25. Grease the inside lip of the Clutch Adjusting Ring and thread it onto the Clutch Housing.
26. Install the Bit Retainer Sleeve Spring (59 or 5). Grease the inside of the bit Retainer Sleeve (58 or 4) and place it onto the Bit Holder.
27. Using a slotted screwdriver, install the Bit Retainer Retaining ring into the groove of the Bit Holder.
28. Unclamp the Assembly Fixture from the vise and turn it over to remove the Clutch and Gear Case.
29. Grease both ends of the Push Rod (46 and 17) and insert it into the Gear Case.

Adjustment of the Brake Switch Timing

1. If the Brake Switch needs adjusting, loosen the Switch Plate Screws (11 or 40). See Dwg. TPD1815.

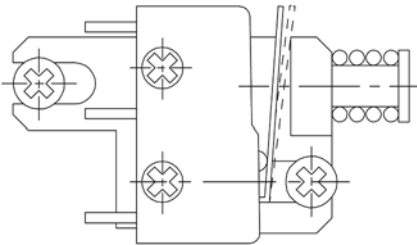

(Dwg. TPD1815)

2. Apply grease to the end of the Plunger (13 or 37) and insert it with the Plunger Spring (14 or 38) into the Switch Plate.
3. Insert a Switch Adjusting Gauge Rod part no. EL0410B-SG into the Motor Assembly.
4. Place the Gear Case and Motor together by aligning the Motor Assembly Springs with the notches in the Gear Case.
5. Place the Assembly into the Housing by aligning the hole in the Motor with the tab in the Housing.
6. Push the Brake Switch forward until the Switch clicks.
7. Tighten the Switch Plate Screws at this position to 1.6 KG-cm.
8. Remove the Switch Adjusting Gauge Rod. Grease and install the Push Rod (35 or 36) into the Motor Assembly and refit the hole in the Motor to the tab in the Housing.

Assembly of the Housing

1. Install the Housing Bushing (7 or 54) in the groove of the Housing.
2. Install the Trigger (17 or 51) with the Trigger Pin (19 or 53) and Spring (18 or 52) into the Housing.
3. Install the second half of the Housing, while holding the Trigger in place.
4. Tighten the Housing Screws (2 or 45) to 1-1/2 inch pounds.

NOTICE

Do not overtighten the Housing Screws.

5. Install the Coupling (56 or 6) with an open end torque wrench and tighten to 7 Nm torque.
6. For repair and trouble shooting of the Controller, refer to the Operations and Maintenance Manual for Model EC24E and EC24U Screwdriver Controllers, Form No. P7215.

Testing the Tool

1. Test forward and reverse operation of the tool by depressing the Trigger with the Reverse Switch (9 or 48) in each position.
2. Tighten the Clutch Adjusting Ring all the way, loosen it one turn and test for proper shut-off and maximum torque using an appropriate tester.
3. Reset the Clutch Adjusting Ring to mid-scale and check torque repeatability by cycling the tool between 5-10 times.

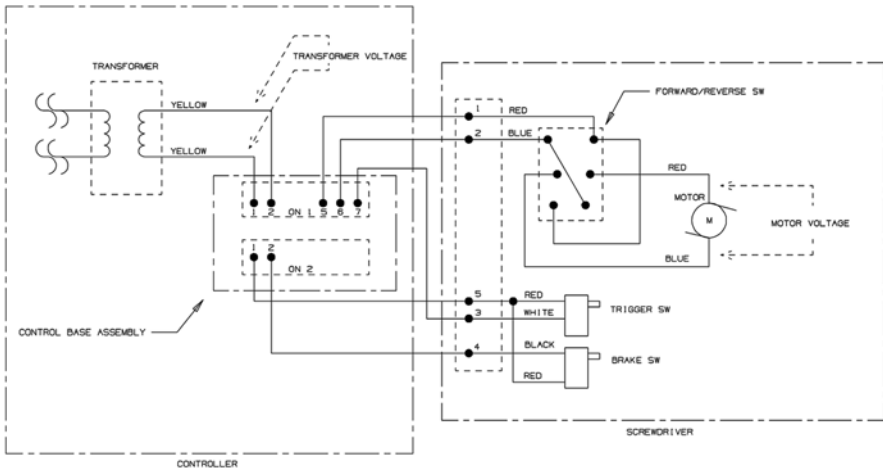

(Dwg. TPD1817)

Troubleshooting Guide

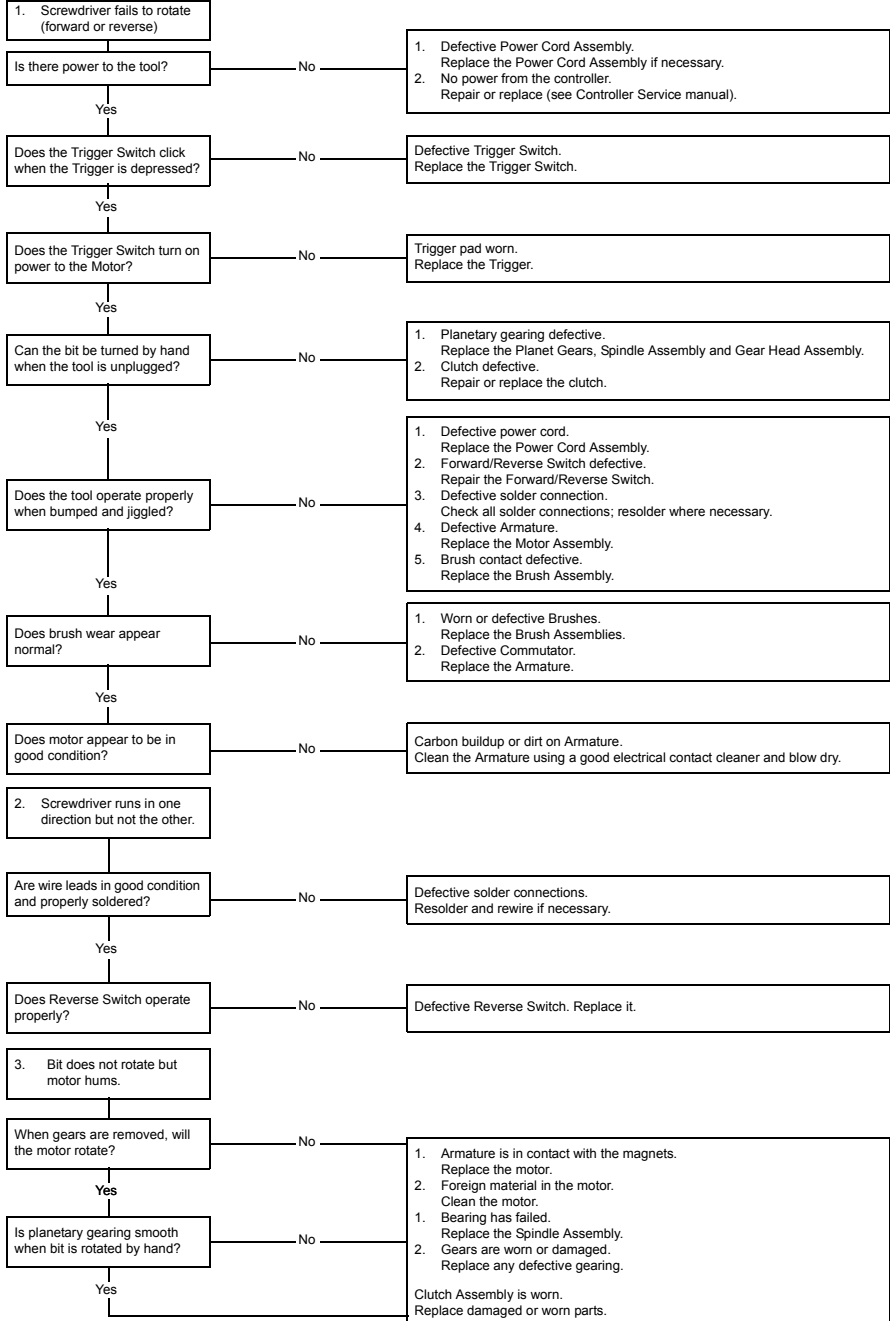

Troubleshooting Guide (Continued)

4. Shutoff brake malfunctions more than one index of the Clutch.

Does the speed of the Bit exceed rated speed by more than 100 rpm?

Yes

Motor magnet is demagnetized.
Replace the motor.

No

Is Brake Switch functioning? (Does it click when button is depressed and does it test correctly with an ohmmeter?)

No

Defective Brake Switch.
Replace the Brake Switch.

Yes

Does Pushrod function properly?

No

Bent or worn Pushrod. Replace it.

Yes

Does Cam function properly?

No

Cam is worn and not providing adequate lift.
Replace the Cam.

Yes

Controller malfunctioning or defective.
Repair or replace. See Controller Service manual.

5. Tool makes abnormal sounds when the motor is running.

Is there looseness at the assembly points?

Yes

1. Screws are loose.
Tighten all Screws.
2. Clutch Housing is loose.
Tighten the Clutch Housing to the proper torque.

No

After removing the gear train does motor sound normal when running?

No

1. Armature (31) is in contact with the Magnet.
Replace the motor
2. Foreign material has gotten into the motor.
Clean or replace the motor.
3. Ball Bearings are defective.
Replace the motor.
4. Armature is defective.
Replace the motor.

Yes

Is the gear train properly lubricate?

No

No grease on the gear train.
Apply a thin film of the recommended grease to the gear train.

Yes

1. Spindle Bearing has failed.
Replace the Spindle Assembly.
2. Gears are worn or dirty.
Clean or replace the gears.

6. Tool generates abnormal heat when operating.

After removing the gear train, does tool cool down and motor run normally?

No

Motor is defective.
Replace the motor.

Yes

Planetary gears and the Clutch require lubrication. Lubricate the Clutch and gear train with the recommended grease.

NOTICE

Do not apply too much or too little grease.

Related Documentation

For additional information refer to:

Electric Screwdrivers Product Safety Information Manual Form 16573685.

Electric Screwdrivers Product Information Manual Form 16578668.

Electric Screwdrivers Product Parts List Manual Form 16574642.

Manuals can be downloaded from www.irttools.com.



www.irttools.com

© 2005 Ingersoll-Rand Company

To Buy Ingersoll Rand Products Online visit AirToolPro.com
Brought to you by Zampani Industrial Group - Factory Authorized Distribution Since 1987 - 1-800-353-4676