

# OPERATOR'S MANUAL

INCLUDING: OPERATION, INSTALLATION & MAINTENANCE  
RANDOM ORBITAL SANDER  
12,000 R.P.M.

Models RO25A-( )-( ) and RO26A-( )-( )

Released: 6-1-95  
Revised: 10-27-95  
Form: P7187  
03541000

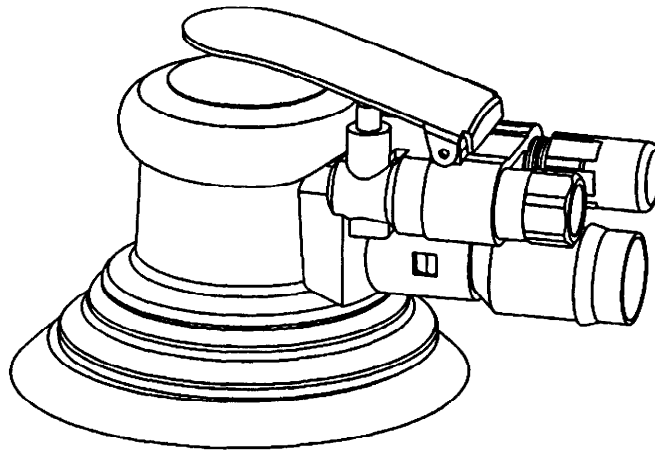

**⚠ WARNING**  
**READ THIS MANUAL CAREFULLY BEFORE INSTALLING,  
OPERATING OR SERVICING THIS EQUIPMENT.**

## FAILURE TO OBSERVE THE FOLLOWING WARNINGS COULD RESULT IN INJURY.

Pneumatic tools should always be installed and used in accordance with A.N.S.I. B186.1 "Safety Code For Portable Air Tools."

### **⚠ WARNING**

- Operate this tool at 90 p.s.i.g. (6.2 bar) maximum air pressure at the air inlet of the tool.
- Disconnect air supply from tool before removing/installing sanding disc, pad or performing maintenance procedures.
- Keep hands, clothing and long hair away from rotating end of tool.
- Anticipate and be alert for sudden changes in motion during start up and operation of any power tool.
- Never exceed rated r.p.m. of tool.
- Wear suitable eye and hearing protection while operating tool.
- Pad will continue to rotate briefly after throttle is released.
- Do not lubricate tools with flammable or volatile liquids such as kerosene, diesel or jet fuel.
- Do not remove any labels. Replace any damaged label.
- Use only accessories recommended by Ingersoll-Rand.
- Do not operate this tool away from the work surface.

### **⚠ WARNING**

Repeated prolonged operator exposure to vibrations which may be generated in the use of certain hand-held tools may produce Raynaud's phenomenon, commonly referred to as Whitefinger disease. The phenomenon produces numbness and burning sensations in the hand and may cause circulation and nerve damage as well as tissue necrosis. Repetitive users of hand-held tools who experience vibrations should closely monitor duration of use and their physical condition.

### **NOTICE**

- The use of other than genuine Ingersoll-Rand replacement parts may result in safety hazards, decreased tool performance and increased maintenance and may invalidate all warranties.
- Ingersoll-Rand is not responsible for customer modification of tools for applications on which Ingersoll-Rand was not consulted.
- Tool maintenance and repair should be performed by authorized, trained, competent personnel. Consult your nearest Ingersoll-Rand authorized servicenter.
- It is the responsibility of the employer to place the information in this manual into the hands of the operator.

For parts and service information, contact your local Ingersoll-Rand distributor, or the Customer Service Dept. of the Ingersoll-Rand Distribution Center, White House, TN at PH: (615) 672-0321, FAX: (615) 672-0801.

**INGERSOLL-RAND®**  
**PROFESSIONAL TOOLS**

**FAILURE TO OBSERVE THE FOLLOWING WARNINGS COULD RESULT IN INJURY.**

**⚠ WARNING**



Wear eye protection when operating or performing maintenance on this tool.

**⚠ WARNING**



Turn off air supply and disconnect air supply hose before installing, removing or adjusting any accessory on this tool, or before performing any maintenance on this tool.

**⚠ WARNING**



Do not carry the tool by the hose.

**⚠ WARNING**



Do not overreach when operating this tool. Keep body stance balanced and firm.

**⚠ WARNING**

Do not operate this tool away from the work surface.

**⚠ WARNING**



Wear hearing protection when operating this tool.

**⚠ WARNING**



Air powered tools can vibrate in use. Vibration, repetitive motions or uncomfortable positions may be harmful to your hands and arms. Stop using any tool if discomfort, tingling feeling or pain occurs. Seek medical advice before resuming use.

**⚠ WARNING**



Do not use damaged, frayed or deteriorated air hoses and fittings.

**⚠ WARNING**

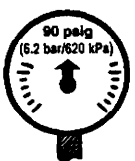

Operate at 90 p.s.i.g. (6.2 bar/620 kPa) maximum air pressure.

**⚠ CAUTION**

Use only sanding pads rated at or above tool r.p.m.

**WARNING** = Hazards or unsafe practices which could result in severe personal injury, death or substantial property damage.

**CAUTION** = Hazards or unsafe practices which could result in minor personal injury or product or property damage.

**NOTICE** = Important installation, operation or maintenance information.

## ROUTINE LUBRICATION REQUIREMENTS

Air line debris, moisture and carry-over oil from the compressor can restrict the muffler and leave contaminants in the motor. Every 160 hours of tool operation, or sooner if motor speeds drop below accepted speed, flush the tool with a solution of equal parts of cleaning solvent and spindle oil. Flush the muffler with cleaning solvent and blow out any trapped debris.

**EVERY 160 HOURS OF TOOL OPERATION** – Inject grease #68, one or two strokes, thru threaded end of spindle (27) for lubrication of needle bearing contained in counterbalance (26). Sanding pad must be removed from spindle to allow injection of grease.

## AIR SUPPLY REQUIREMENTS

This tool has been designed to operate without air line lubrication. Introduction of a lubricant with a standard filter/regulator/lubricator will not effect tool life.

For maximum operating efficiency, the following air supply specifications should be maintained to this air tool:

- AIR PRESSURE – 90 p.s.i.g. (6.2 bar)
- AIR FILTRATION – 50 micron
- HOSE SIZE – 5/16" (8 mm) I.D.

An IR model C05-02-G00 air line FILTER/REGULATOR/LUBRICATOR is recommended to maintain the above air supply of air to the tool.

## RECOMMENDED LUBRICANTS

After disassembly is complete, all parts, except sealed or shielded bearings, should be washed with solvent. To relubricate parts, or for routine lubrication, use the following recommended lubricants:



<u>Where Used</u>	<u>IR Part #</u>	<u>Description</u>
"O" Rings & Lip Seals	IR36460	4 oz. Stringy Lubricant
Gears and Bearings	#68	5 lb. "EP" – NLGI #1 Grease

## INSPECTION, MAINTENANCE AND INSTALLATION

Disconnect air supply from the tool or shut off air supply and exhaust (drain) line of compressed air before performing maintenance or service to the tool.

It is important that the tools be serviced and inspected at regular intervals for maintaining safe, trouble-free operation of the tool.

Be sure that the air supply lines and connectors are of proper size to provide a sufficient quantity of air to the tool.

Tool maintenance and repair shall be performed by authorized, trained, competent personnel. Tools, hose and fittings shall be replaced if unsuitable for safe operation and responsibility should be assigned to be sure that all tools requiring guards or other safety devices shall be kept in legible condition. Maintenance and repair records should be maintained on all tools. Frequency of repair and the nature of the repairs can reveal unsafe application. Scheduled maintenance by competent authorized personnel should detect any mistreatment or abuse of the tool and worn parts. Corrective action should be taken before returning the tool for use.

Disassembly should be done on a clean work bench with a clean cloth spread to prevent the loss of small parts. After disassembly is completed, all parts should be thoroughly washed in a clean solvent, blown dry with air and inspected for wear levels, abuse and contamination. Double sealed or shielded bearings should never be placed in solvent unless a good method of re-lubricating the bearing is available. Open bearings may be washed but should not be allowed to spin while being blown dry.

Upon reassembling, lubricate parts where required. Use #68 grease, or equivalent, in bearings. Use IR36460 lubricant for "O" ring assembly. When assembling "O" rings or parts adjacent "O" rings, care must be exercised to prevent damage to the rubber sealing surfaces. A small amount of grease will usually hold steel balls and other small parts in place while assembling.

When replacement parts are necessary, consult drawing containing the part for identification.

Always use clean, dry air. Dust, corrosive fumes and/or excessive moisture can damage the motor of an air tool. An air line filter can greatly increase the life of an air tool. The filter removes rust, scale, moisture and other debris from the air lines. Low air pressure (less than 90 p.s.i.g.) reduces the speed of the air tool. High air pressure (more than 90 p.s.i.g.) raises performance beyond the rated capacity of the tool and could cause injury. Shown below is a typical piping arrangement.

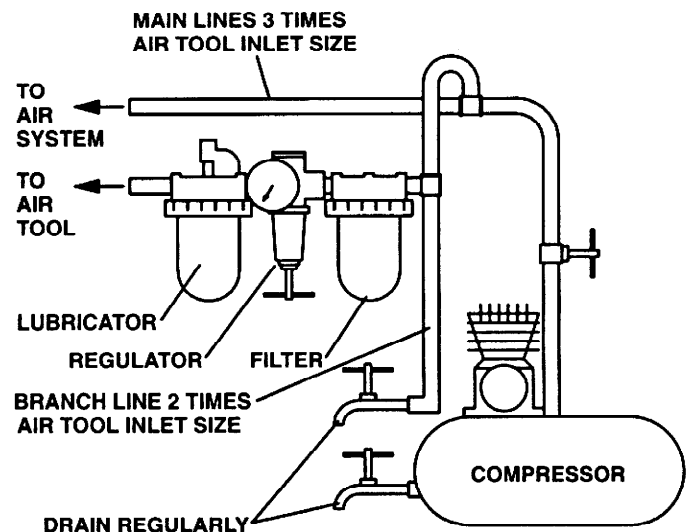

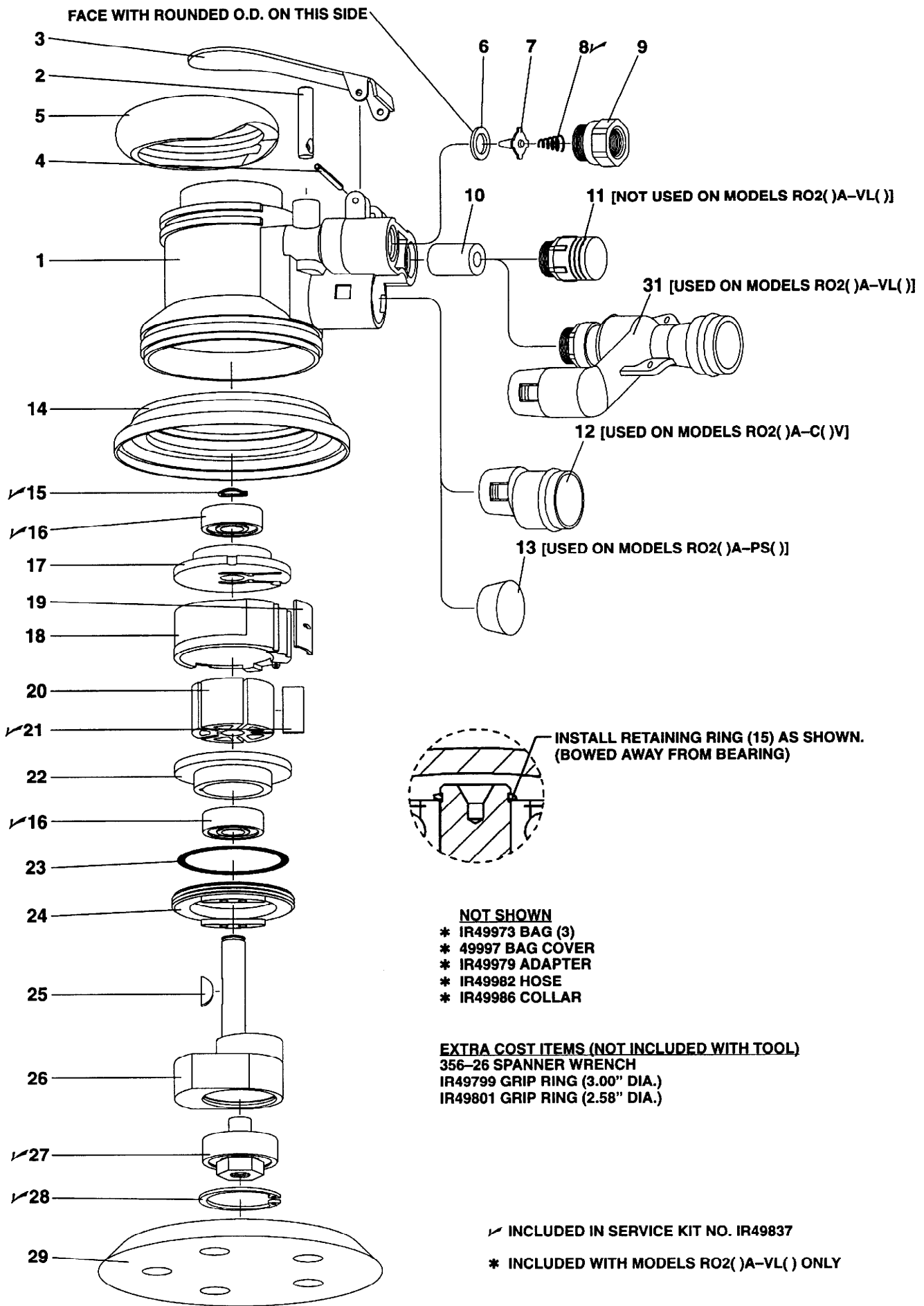

## MODEL NUMBER IDENTIFICATION

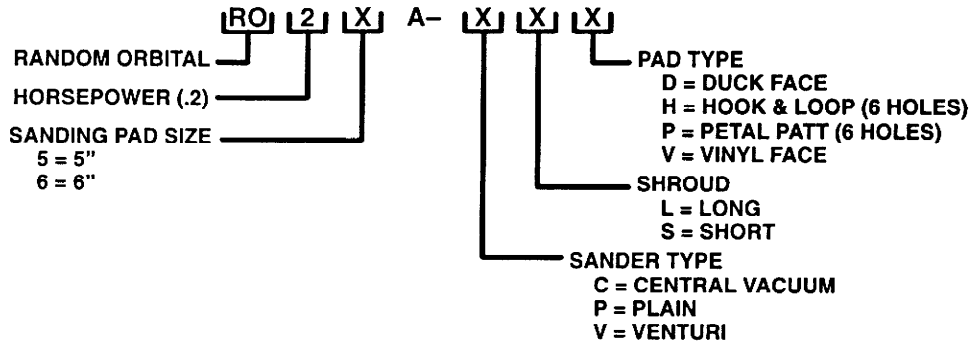

MODEL NUMBER	LEVER (ITEM 3)	SHROUD (ITEM 14)	PAD (ITEM 29)	PAD DESCRIPTION
RO25A-CLH	356-273	IR48876	IR49849	5" HOOK & LOOP
RO25A-CLP	356-273	IR48876	IR49848	5" PETAL PATT
RO25A-CLV	356-273	IR48876	IR49096-1	5" VINYL FACE
RO25A-CLV-EU	356-273-1	IR48876	IR49096-1	5" VINYL FACE
RO25A-CSV	356-273	IR48266-1	IR49096-1	5" VINYL FACE
RO25A-CSV-EU	356-273-1	IR48266-1	IR49096-1	5" VINYL FACE
RO25A-PSD	356-273	IR48266-1	IR49877-1	5" DUCK FACE
RO25A-PSD-EU	356-273-1	IR48266-1	IR49877-1	5" DUCK FACE
RO25A-PSP	356-273	IR48266-1	IR49848	5" PETAL PATT
RO25A-PSV	356-273	IR48266-1	IR49878-1	5" VINYL FACE
RO25A-PSV-EU	356-273-1	IR48266-1	IR49878-1	5" VINYL FACE
RO25A-VLH	356-273	IR48876	IR49849	5" HOOK & LOOP
RO25A-VLP	356-273	IR48876	IR49848	5" PETAL PATT
RO25A-VLV	356-273	IR48876	IR49096-1	5" VINYL FACE
RO25A-VLV-EU	356-273-1	IR48876	IR49096-1	5" VINYL FACE
RO26A-CLV	356-273	356-931	354-825-6A	6" VINYL FACE
RO26A-CLV-EU	356-273-1	356-931	354-825-6A	6" VINYL FACE
RO26A-CSV	356-273	IR48266-1	354-825-6A	6" VINYL FACE
RO26A-CSV-EU	356-273-1	IR48266-1	354-825-6A	6" VINYL FACE
RO26A-PSD	356-273	IR48266-1	IR49880-1	6" DUCK FACE
RO26A-PSD-EU	356-273-1	IR48266-1	IR49880-1	6" DUCK FACE
RO26A-PSV	356-273	IR48266-1	IR49879-1	6" VINYL FACE
RO26A-PSV-EU	356-273-1	IR48266-1	IR49879-1	6" VINYL FACE
RO26A-VLV	356-273	356-931	354-825-6A	6" VINYL FACE
RO26A-VLV-EU	356-273-1	356-931	354-825-6A	6" VINYL FACE

MODELS WITH -EU SUFFIX ARE "EC" COMPLIANT MODELS.

PART NUMBER FOR ORDERING

PART NUMBER FOR ORDERING

1	Housing (includes pin) .....	49816-2	19	Seal .....	IR49819
2	Valve Stem .....	IR48065-2	20	Rotor .....	356-53
3	Lever .....	See table	21	Blade (5 req'd) .....	IR48254-1
4	Roll Pin .....	356-15	22	Front End Plate .....	356-11
5	Grip Ring .....	IR49798	23	"O" Ring .....	356-259
6	Seat .....	351-210	24	Lock Ring .....	356-218
7	Tip Valve .....	351-302	25	Key .....	351-405
8	Spring .....	351-51	26	Counterbalance (includes needle bearing) for 5" pad models .....	IR49808-5
9	Inlet Adapter .....	IR49824		for 6" pad models .....	351-236A
10	Muffler Tube .....	356-111	27	Spindle Assembly (includes bearing) ...	351-8A
11	Muffler .....	IR49818	28	Retaining Ring .....	351-28A
12	Vacuum Adapter .....	IR49802	29	Sanding Pad .....	See table
13	Tapered Plug .....	IR49821	30	Wrench (not shown) .....	354-69
14	Shroud .....	See table	31	Eductor Assembly .....	IR49976
15	Retaining Ring .....	351-119		Service Kit: includes items 8, 15, 16, 21, 27 and 28 .....	IR49837
16	Bearing (2 req'd) .....	351-24			
17	Rear End Plate .....	356-12			
18	Cylinder (includes roll pin) .....	IR49815			

# DISASSEMBLY/ASSEMBLY INSTRUCTIONS

## NOTICE

- Never apply excessive pressure by a holding device which may cause distortion of a part.
- Apply pressure evenly to parts which have a press fit.
- Apply even pressure to the bearing race that will be press fitted to the mating part.
- Use correct tools and fixtures when servicing this tool.
- Don't damage "O" rings when servicing this tool.
- Use only genuine Ingersoll-Rand replacement parts for this tool. When ordering, specify part number, description, tool model number and serial number.

## MOTOR DISASSEMBLY

- Remove sanding pad (24).
- Remove retaining ring (28).
- Remove spindle assembly (27) (includes bearing). NOTE: Do not attempt to remove bearing from spindle.
- Remove lock ring (24) and pull motor and seal (19) from housing.
- Remove retaining ring (15).
- Using special brass blocks to fit around o.d. of cylinder, clamp around cylinder and press shaft of counterbalance thru bearing (16) and end plate (17).
- Remove blades (21), rotor (20) and key (25).
- Remove end plate (22) and bearing (16).

## MOTOR ASSEMBLY

- Grease and assemble "O" ring (23) to lock ring (24).
- Assemble lock ring (24) over counterbalance (26).
- Assemble bearing (16) into end plate (22), pressing on outer race of bearing.
- Assemble end plate (22) onto shaft of counterbalance, pressing on inner race of bearing.
- Install key (25) in key slot.
- Assemble rotor (20) to counterbalance, aligning keyway to key (25).
- Assemble five rotor blades (21) to rotor slots.
- Assemble cylinder (18) over rotor, aligning roll pin in cylinder with slot in end plate.
- Assemble bearing (16) into end plate (17), pressing on outer race of bearing.
- Assemble end plate (17), with bearing (16), to counterbalance, pressing on inner race of bearing. NOTE: Align slot in end plate with roll pin in cylinder.

- Install retaining ring (15) to groove in counterbalance, with bow in ring positioned as shown on parts illustration page.
- Assemble seal (19) to grooves in cylinder.
- Assemble motor to housing, aligning seal (19) with air inlet.
- Tighten lock ring (24), securing motor assembly.
- Lubricate needle bearing, contained in counterbalance, with IR #68 grease.
- Assemble spindle assembly (27) to counterbalance, securing with retaining ring (28).
- Assemble sanding pad (29) to tool and tighten securely.

## THROTTLE DISASSEMBLY

- Remove vacuum adapter (12)(if applicable) by pressing in on tabs and pulling vacuum adapter out.
- Models RO2( )A-VLV: Remove eductor assembly (31)(if applicable). To remove, unthread upper section, press in on tabs of lower section and pull assembly from housing.
- Remove inlet adapter (9), releasing spring (8) and valve (7). NOTE: Do not remove seat (6) unless damage is evident.
- Remove muffler (11), releasing muffler tube (10).
- To remove valve stem (2), remove roll pin (4) and lever (3).

## THROTTLE ASSEMBLY

- Assemble valve stem (2) into housing with hole in valve stem in line with housing to accept valve (7).
- Assemble seat (6) into housing with rounded corners into housing first.
- Assemble valve (7) into housing, securing valve stem (2).
- Assemble spring (8) into housing.
- Assemble inlet adapter (9) to housing, securing throttle components.
- Assemble lever (3) to housing, securing with roll pin (4).
- Assemble vacuum adapter (12) or plug (13) to housing. To assemble vacuum adapter, push into housing until tabs on vacuum adapter snap into slots in housing. To assemble plug, push into housing until it is flush with port opening.
- Models RO2( )A-VLV: Assemble eductor assembly (31) to housing. To assemble, insert tapered section of eductor assembly into housing while aligning threaded section with housing. Using a wrench on flats, tighten threaded section securely. Tabs will snap into slots in housing.

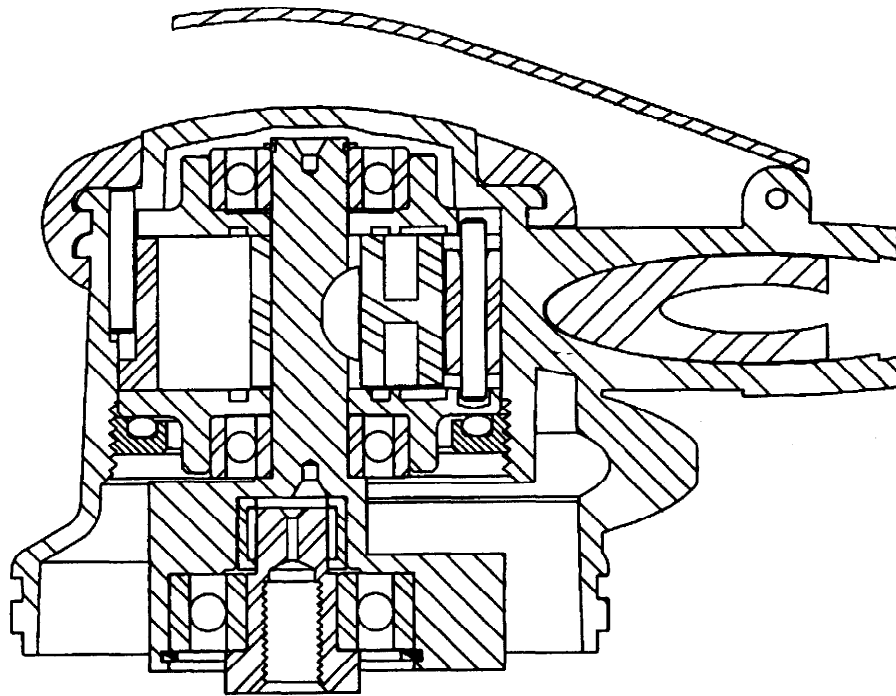

**INGERSOLL-RAND®**  
**PROFESSIONAL TOOLS**

PN 49999-488

To Buy Ingersoll Rand Products Online visit [AirToolPro.com](http://AirToolPro.com)  
Brought to you by Zampini Industrial Group - Factory Authorized Distribution Since 1987 - 1-800-353-4676