

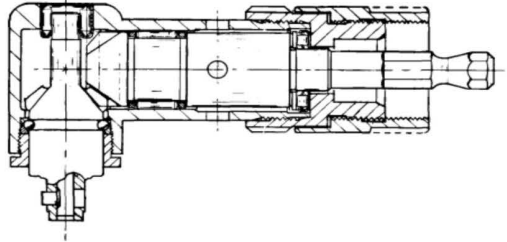

ANGLE HEAD KIT 1/4" SQ DRIVE

91492

ANGLE HEAD KIT 1/4" SQ DRIVE



⚠	WARNING - ATTENTION - WARNUNG - ADVERTENCIA - AVISO - AVVISO WAARSCHUWING - ADVARSEL - VAROITUS - VARNING - ΠΡΟΕΙΔΟΠΟΙΗΣΗ	📄
EN	TO REDUCE THE RISK OF INJURY, BEFORE USING OR SERVICING TOOL, READ AND UNDERSTAND THE FOLLOWING INFORMATION AS WELL AS SEPARATELY PROVIDED SAFETY INSTRUCTIONS (ITEM NUMBER: 370273)	
FR	AFIN DE LIMITER LES RISQUES DE BLESSURES, AVANT D'UTILISER OU DE RÉPARER L'OUTIL, LISEZ ET ASSIMILEZ LES INFORMATIONS SUIVANTES AINSI QUE LES INSTRUCTIONS DE SÉCURITÉ FOURNIES SÉPARÉMENT (CODE D'ARTICLE : 370273)	
DE	ZUR VERRINGERUNG DES VERLETZUNGSRIKOS SIND VOR DER INBETRIEBNAHME ODER WARTUNG DES WERKZEUGS FOLGENDE INFORMATIONEN SOWIE DIE GETRENNT BEILIEGENDEN SICHERHEITSANWEISUNGEN (ARTIKELNR. 370273) SORGFÄLTIG ZU LESEN	
ES	PARA REDUCIR EL RIESGO DE LESIONES, ANTES DE UTILIZAR O REVISAR LA HERRAMIENTA, LEA DETENIDAMENTE LA SIGUIENTE INFORMACIÓN Y LAS INSTRUCCIONES DE SEGURIDAD PROPORCIONADAS POR SEPARADO (NÚMERO DE COMPONENTE: 370273)	
PT	PARA REDUZIR O RISCO DE OCORRÊNCIA DE FERIMENTOS, ANTES DE UTILIZAR A FERRAMENTA DE ASSISTÊNCIA LEIA ATENTAMENTE A INFORMAÇÃO QUE SE SEGUE, BEM COMO AS INSTRUÇÕES DE SEGURANÇA FORNECIDAS EM SEPARADO (NÚMERO DE ARTIGO: 370273)	
IT	PER RIDURRE IL RISCHIO DI LESIONI, PRIMA DI UTILIZZARE O RIPARARE L'UTENSILE, LEGGERE ATTENTAMENTE LE INFORMAZIONI RIPORTATE DI SEGUITO OLTRE ALLE ISTRUZIONI DI SICUREZZA FORNITE SEPARATAMENTE (N. ARTICOLO: 370273)	
NL	OM HET RISICO VAN VERWONDING TIJDENS HET GEBRUIK VAN DIT PRODUCT OF TIJDENS ONDERHOUD TE VERMIJDEN, DIENEN DE HIERNA VOLGENDE INFORMATIE EN DE APART VERSTREKTE VEILIGHEIDSinSTRUCTIES GOED GELEZEN TE WORDEN (ONDERDEELNUMMER: 370273)	
DA	FOR AT NEDSÆTTE RISIKOEN FOR LEGEMSBESKADIGELSE SKAL DU LÆSE OG FORSTÅ FØLGENDE INFORMATION SAMT DE SIKKERHEDSinSTRUKTIONER, DER MEDFØLGER SÆRSKILT (DELNUMMER: 370273), FØR DU ANVENDER ELLER UDFØRER SERVICE PÅ VÆRKTØJET	
NO	FOR Å REDUSERE FAREN FOR SKADE MÅ DU LESE OG FORSTÅ FØLGENDE OPPLYSNINGER SAMT INSTRUKSJONENE SOM LEVERES SEPARAT (ARTIKKELNUMMER: 370273), FØR DU BRUKER VERKTØYET ELLER UTFØRER SERVICE PÅ DET	
FI	TAPATURMAVAARAN PIENENTÄMISEKSI LUE ENNEN HUOLTOLAITTEEN KÄYTTÖÄ SEURAAVAT TIEDOT JA ERIKSEEN TOIMITETUT TURVALLISUUSOHJEET NIIN, ETTÄ YMMÄRRÄT NE (ERÄNUMERO: 370273)	
SV	FÖR ATT MINSKA RISKEN FÖR SKADOR MÅSTE DU INNAN DU ANVÄNDER UTRUSTNINGEN ELLER UTFÖR SERVICE PÅ DEN LÄSA OCH VARA INFÖRSTÄDD MED FÖLJANDE INFORMATION SAMT DE SÄKERHETSANVISNINGAR SOM TILLHANDAHÅLLS SEPARAT (ARTIKELNUMMER: 370273)	
EL	ΓΙΑ ΝΑ ΠΕΡΙΟΡΙΣΤΕΙ Ο ΚΙΝΔΥΝΟΣ ΤΡΑΥΜΑΤΙΣΜΟΥ, ΠΡΙΝ ΑΠΟ ΤΗ ΧΡΗΣΗ Η ΤΗ ΣΥΝΤΗΡΗΣΗ ΤΟΥ ΕΡΓΑΛΕΙΟΥ, ΝΑ ΔΙΑΒΑΣΕΤΕ ΚΑΙ ΝΑ ΚΑΤΑΝΟΗΣΕΤΕ ΤΙΣ ΠΑΡΑΚΑΤΩ ΠΛΗΡΟΦΟΡΙΕΣ, ΚΑΘΩΣ ΚΑΙ ΤΙΣ ΟΔΗΓΙΕΣ ΓΙΑ ΤΗΝ ΑΣΦΑΛΕΙΑ ΠΟΥ ΔΙΝΟΝΤΑΙ ΣΕΧΩΡΙΣΤΑ (ΚΩΔΙΚΟΣ ΕΙΔΟΥΣ: 370273)	

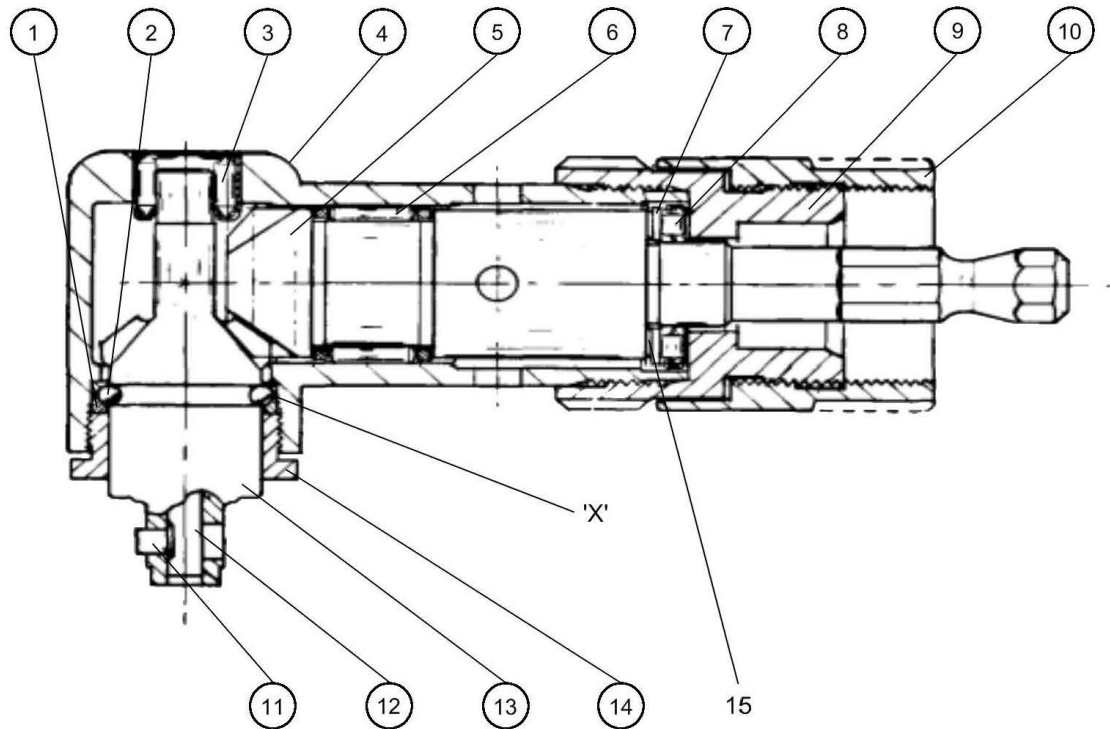

Ref. No.	Ordering No.	Qty	Description	Remark / Included in Service kit
1	77423	2	Outside ball race	
2	3893	20	Ball Ø5/64"	
3	77393	1	Needle roller assembly	
4	262783	1	Angle body 90 degree	
5	262833	1	Drive bevel	
6	77463	1	Split caged needle	
7	262803	1	Bearing washer	
8	179443	1	Thrust race	
9	262813	1	Bearing clamp	
10	262823	1	Locking adaptor	
11	89003	1	Retaining pin	
12	89013	1	Rubber spring	
13	88893	1	Bevel spindle	
14	77403	1	Clamp nut	
15	-	-	Shims	~ .014" nominal required
	307243	1	Bit holder 1/4" F6.3	
	169063	1	Spacing washer .095"	

Service Instructions

Item 1 (77423), Outside ball race, must be fitted on assembly by removing material from interface 'X' to achieve an axial clearance not exceeding 0.15 mm (.006") and a radial clearance not exceeding 0.15 mm (.006") within 2 mm of item 14 (77403), Clamp nut and maintaining a free running condition.

Item 15, Shims, adjust Drive bevel position to achieve smoothest running. Under nominal tolerance conditions this will occur with an axial Drive bevel movement (endfloat) of 0.3 mm (.012").

Provisional tightening torques

Items 4 & 14 : 11-15 Nm 8-11 lbf.ft

Items 4 & 9 : 23-27 Nm 17-20 lbf.ft

To avoid damage to bearings, torque used on item 10 to mount head on tool must not exceed 12 Nm (9 lbf.ft).